

# Engine Mechanical - 8.1L

## Specifications

### Fastener Tightening Specifications

Application	Specification	
	Metric	English
Air Injection Pipe Bolt	25 N•m	19 lb ft
Air Injection Pipe Nut	12 N•m	106 lb in
Air Injection Pump Pipe Bolt	50 N•m	37 lb ft
Air Injection Pump Pipe Nut	12 N•m	106 lb in
Camshaft Position Sensor Bolt	12 N•m	106 lb in
Camshaft Retainer Bolt	12 N•m	106 lb in
Camshaft Sprocket Bolt	30 N•m	22 lb ft
Connecting Rod Nut	30 N•m + 90 Degrees	22 lb ft + 90 Degrees
Coolant Drain Hole Plug		
Left Front	60 N•m	44 lb ft
Sides	20 N•m	15 lb ft
Crankshaft Balancer Bolt	255 N•m	189 lb ft
Crankshaft Bearing Cap Bolt		
First Pass	30 N•m	22 lb ft
Final Pass	90 Degrees	
Crankshaft Bearing Cap Stud		
First Pass	30 N•m	22 lb ft
Final Pass	80 Degrees	
Crankshaft Oil Deflector Nut	50 N•m	37 lb ft
Crankshaft Position Sensor Bolt	12 N•m	106 lb in
Cylinder Head Bolt (In Sequence)		
First Pass	30 N•m	22 lb ft
Second Pass	30 N•m + 120 Degrees	22 lb ft + 120 Degrees
Final Pass - Long Bolts #1, 2, 3, 6, 7, 8, 9, 10, 11, 14, 16, 17	60 Degrees	
Final Pass - Medium Bolts #15, 18	45 Degrees	
Final Pass - Short Bolts #4, 5, 12, 13	30 Degrees	
Cylinder Head Coolant Hole Plug	23 N•m	17 lb ft
Drive Belt Tensioner Bolt	50 N•m	37 lb ft
EGR Vacuum Regulator Bracket Bolt	30 N•m	22 lb ft
EGR Valve Bolt	30 N•m	22 lb ft
EGR Valve Pipe Bolt	30 N•m	22 lb ft
EGR Valve Pipe Bracket Bolt	50 N•m	37 lb ft
EGR Valve Pipe Nut	30 N•m	22 lb ft
EGR Valve Pipe Stud	12 N•m	106 lb in
Engine Coolant Temperature (ECT) Sensor	20 N•m	15 lb ft
Engine Coolant Temperature (ECT) Sensor Bracket Bolt	50 N•m	37 lb ft
Exhaust Manifold		
Center Bolt	35 N•m	26 lb ft

## Fastener Tightening Specifications (cont'd)

Application	Specification	
	Metric	English
Nut	16 N•m	12 lb ft
Stud	20 N•m	15 lb ft
Exhaust Manifold Heat Shield		
Bolt	25 N•m	19 lb ft
Nut	25 N•m	19 lb ft
Flywheel Bolt	100 N•m	74 lb ft
Flywheel Cover Bolt	12 N•m	106 lb in
Flywheel Housing		
Hex Head Bolt	67 N•m	50 lb ft
Countersunk Bolt	60 N•m	44 lb ft
Front Cover Bolt	12 N•m	106 lb in
Fuel Rail Stud	12 N•m	106 lb in
Ignition Coil Bolt	12 N•m	106 lb in
Ignition Coil Wiring Harness Bolt	12 N•m	106 lb in
Intake Manifold Bolt (In Sequence)	12 N•m	106 lb in
Knock Sensor	20 N•m	15 lb ft
Knock Sensor Heat Sheild Bolt - C/K/G/C3500HD	12 N•m	106 lb in
Knock Sensor Heat Sheild Bolt - Medium Duty	50 N•m	37 lb ft
MAP Sensor Bolt	12 N•m	106 lb in
Oil Cooler Hose Fittings	23 N•m	17 lb ft
Oil Fill Tube Bolt	12 N•m	106 lb in
Oil Filter	38 N•m	12 lb ft
Oil Filter Fitting	66 N•m	49 lb ft
Oil Gallery Plug		
Front	30 N•m	22 lb ft
Left	30 N•m	22 lb ft
Rear	30 N•m	22 lb ft
Top	20 N•m	15 lb ft
Oil Level Indicator Tube Bracket Nut	18 N•m	13 lb ft
Oil Level Switch	14 N•m	10 lb ft
Oil Pan Bolt	25 N•m	18 lb ft
Oil Pan Drain Plug	28 N•m	21 lb ft
Oil Pressure Gauge Sensor	30 N•m	22 lb ft
Oil Pump Bolt	75 N•m	56 lb ft
Oil Pump Cover Bolt	12 N•m	106 lb in
Oil Pump Drive Bolt	25 N•m	19 lb ft
Purge Solenoid Bolt	10 N•m	88 lb in
Spark Plug	20 N•m	15 lb ft
Thermostat Housing Bolt	30 N•m	22 lb ft
Throttle Body		
Nut	10 N•m	88 lb in
Stud	12 N•m	106 lb in

**Fastener Tightening Specifications (cont'd)**

<b>Application</b>	<b>Specification</b>	
	<b>Metric</b>	<b>English</b>
Transmission Converter Cover Bolts	12 N•m	106 lb in
Valve Lifter Guide Retainer Bolt	25 N•m	19 lb ft
Valve Rocker Arm Cover Bolt	12 N•m	106 lb in
Valve Rocker Arm Nut	25 N•m	19 lb ft
Valve Rocker Arm Stud	50 N•m	37 lb ft
Water Crossover Pipe Bolt	50 N•m	37 lb ft
Water Pump Bolt	50 N•m	37 lb ft
Water Pump Pulley Bolt	25 N•m	19 lb ft

## Engine Mechanical Specifications

Application	Specification	
	Metric	English
<b>General Data</b>		
Engine Type	V-8	
RPO	L18	
Displacement	8.1L	496 CID
Bore	107.950 mm	4.250 in
Stroke	111.00 mm	4.370 in
Compression Ratio	9.1:1	
Firing Order	1-8-7-2-6-5-4-3	
Spark Plug Gap	1.52 mm	0.060 in
<b>Cylinder Head</b>		
Surface Flatness	0.050 mm	0.002 in
Maximum Cylinder Head Block Deck Resurfacing	0.3048 mm	0.012 in
<b>Exhaust Manifold</b>		
Surface Flatness	0.254 mm	0.010 in
<b>Lubrication System</b>		
Oil Capacity without Filter Change	-	-
Oil Pressure (Minimum)	34 kPa @ 1,000 RPM	5 psi @ 1,000 RPM
Oil Pressure (Maximum)	69 kPa @ 2,000 RPM	10 psi @ 2,000RPM
Oil Filter System	Full Flow	
Oil Pump Type	Gear Driven	
<b>Cylinder Bore</b>		
Diameter - Production	107.950-107.968 mm	4.2500-4.2507 in
Diameter - Service	107.940-107.990 mm	4.2496-4.2516 in
Out-of-Round Production (Maximum Minus Minimum Bore Diameter)	0.0180 mm (Maximum)	0.0007 in (Maximum)
Out-of-Round Service (Maximum Minus Minimum Bore Diameter)	0.050 mm (Maximum)	0.002 IN (Maximum)
Taper Production	0.0180 mm (Maximum)	0.0007 in (Maximum)
Taper Service - Thrust Axis	0.050 mm (Maximum)	0.002 in (Maximum)
Taper Service - Pin Axis	0.050 mm (Maximum)	0.002 in (Maximum)
<b>Engine Block (Production Specifications)</b>		
Main Bearing Bore Diameter	74.6060-74.6220 mm	2.9372-2.9379 in
Lifter Bore Diameter	21.417-21.443 mm	0.843-0.844 in
Deck Height from Crankshaft Bore	259.875-260.125 mm	10.231-10.241 in
Head Deck Surface Flatness (entire face)	0.100 mm	0.004 in
Head Deck Surface Flatness within 150 mm (6 in)	0.050 mm	0.002 in
<b>Piston</b>		
Piston Diameter (Coated Piston)	Not Measurable	Not Measurable
Clearance Production	Interference Fit (Coated Piston)	Interference Fit (Coated Piston)
<b>Piston Ring Compression</b>		
Top Groove Clearance	0.031-0.074 mm	0.0012-0.0029 in
Second Groove Clearance	0.031-0.074 mm	0.0012-0.0029 in
Top Ring Production Gap	0.300-0.450 mm	0.012-0.018 in
Top Ring Service Limit Gap	0.450-0.675 mm	0.018-0.027 in
Second Ring Production Gap	0.450-0.650 mm	0.017-0.025 in
Second Ring Service Limit Gap	0.675-0.975 mm	0.026-0.039 in
<b>Piston Ring Oil Control</b>		
Ring Groove Clearance	0.051-0.203 mm	0.002-0.008 in
Production Gap	0.249-0.759 mm	0.0098-0.0299 in
Service Limit Gap	0.373-1.138 mm	0.015-0.045 in
<b>Piston Pin</b>		
Diameter	26.416-26.419 mm	1.0400-1.0401 in
Fit in Connecting Rod	0.049-0.020 mm Interference	0.00019-0.0007 in Interference

## Engine Mechanical Specifications (cont'd)

<b>Crankshaft</b>		
Crankshaft Main Journal Runout - Production	0.0380 mm (Maximum)	0.0015 in (Maximum)
Crankshaft Main Journal Runout - Service	0.0510 mm (Maximum)	0.0020 in (Maximum)
Crankshaft Journal Diameter #1, #2, #3, #4, #5	69.805-69.822 mm	2.7482-2.7489 in
Crankshaft Journal Taper Production	0.0102 mm (Maximum)	0.0004 in (Maximum)
Crankshaft Journal Taper Service Limit	-	-
Crankshaft Journal Out-of-Round Production	0.0102 mm (Maximum)	0.0004 in (Maximum)
Crankshaft Journal Out-of-Round Service Limit	-	-
Crankshaft Bearing Clearance #1, #2, #3, #4 Production	0.022-0.052 mm	0.0008-0.0020 in
Crankshaft Bearing Clearance #5 Production	0.035-0.067 mm	0.0014-0.0026 in
Crankshaft Bearing Clearance #1, #2, #3, #4 Service Limit	0.022-0.089 mm	0.0008-0.0035 in
Crankshaft Bearing Clearance #5 Service Limit	0.035-0.102 mm	0.0014-0.0040 in
Crankshaft End Play	0.127-0.279 mm	0.0050-0.0110 in
Crankshaft Thrust Wall Width	-	-
Crankshaft Thrust Wall Maximum Runout	-	-
Crankpin Diameter	55.854-55.870 mm	2.1990-2.1996 in
Crankpin Taper Production	0.0102 mm (Maximum)	0.0004 in (Maximum)
Crankpin Taper Service Limit	-	-
Crankpin Out-of-Round Production	0.0102 mm (Maximum)	0.0004 in (Maximum)
Crankpin Out-of-Round Service Limit	-	-
Rod Bearing Clearance Production	0.021-0.064 mm	0.0008-0.0025 in
Rod Bearing Clearance Service Limit	0.021-0.081 mm	0.0008-0.0032 in
Connecting Rod Side Clearance	0.384-0.686 mm	0.0151-0.0270 in
<b>Camshaft</b>		
Camshaft Runout - Production	0.051 mm (Maximum)	0.003 in (Maximum)
Camshaft Runout - Service	0.076 mm (Maximum)	0.002 in (Maximum)
Lobe Lift Intake	6.924-7.026 mm	0.2726-0.2766 in
Lobe Lift Exhaust	6.973-7.075 mm	0.2745-0.2785 in
Journal Diameter	49.472-49.522 mm	1.9477-1.9479 in
Camshaft Bearing Inside Diameter	49.5480-49.5730 mm	1.9507-1.9517 in
<b>Valve System</b>		
Lifter	Hydraulic, Roller Followers	
Rocker Arm Ratio	1.70:1	
Valve Lash Intake	Net Lash	
Valve Lash Exhaust	Net Lash	
Face Angle (Intake/Exhaust)	45 degrees	
Seat Angle (Intake/Exhaust)	46 degrees	
Seat Runout (Intake/Exhaust)	0.050 mm (Maximum)	0.002 in (Maximum)
Seat Width Intake	0.800-1.200 mm	0.030-0.060 in
Seat Width Exhaust	1.651-2.159 mm	0.060-0.095 in
Stem Clearance Production Intake	0.025-0.0740 mm	0.0010-0.0029 in
Stem Clearance Production Exhaust	0.030-0.079 mm	0.0012-0.0031 in
Stem Clearance Service Intake	-	-
Stem Clearance Service Exhaust	-	-
Valve Spring Pressure Closed	381-419 N@ 45.923 mm	86-94 lb@1.808 in
Valve Spring Pressure Open	962-1058 N@ 33.985 mm	216-236 lb@1.338 in
Valve Spring Installed Height	45.923-46.685 mm	1.808-1.838 in
Valve Spring Free Length	56.35 mm	2.218 in
Valve Head Diameter Intake	55.63 mm	2.19 in
Valve Head Diameter Exhaust	43.69 mm	1.72 in
Valve Stem Diameter Intake	9.436-9.454 mm	0.3715-0.3722 in
Valve Stem Diameter Exhaust	9.431-9.449 mm	0.3713-0.3720 in

**Engine Mechanical Specifications (cont'd)**

Maximum Valve Spring Installed Height Shim (Service Only)	0.726 mm	0.030 in
Maximum Valve Spring Tension Shim (Service Only)	0.726 mm	0.030 in
Maximum Combined Valve Spring Installed Height and Valve Spring Tension Shim	1.524 mm	0.060 in

**GM SPO Group Numbers**

<b>Application</b>	<b>GM SPO Group Number</b>
Camshaft	0.519
Camshaft Sprocket	0.736
Camshaft Timing Chain	0.724
Crankshaft	0.646
Crankshaft Bearing Kit	0.096
Crankshaft Sprocket	0.728
Connecting Rod	0.603
Cylinder Head	0.269
Cylinder Head Gasket Kit	0.289
Camshaft Position Sensor Gasket Kit	2.363
Exhaust Gas Recirculation (EGR) Valve	3.670
EGR Valve Gasket	3.680
Exhaust Manifold	3.601
Exhaust Manifold Gasket	3.270
Engine Front Cover	0.206
Engine Front Cover Gasket	0.207
Intake Manifold (with gasket)	3.265
Oil Filter	1.836
Oil Level Indicator	1.516
Oil Pan	1.426
Oil Pan Gasket	1.429
Oil Pump Cover	1.723
Oil Pump Cover Gasket	1.724
Oil Pump (with gasket)	1.652
Piston Ring Kit	0.643
Spark Plug	2.270
Valve Lifter	0.459
Thermostat	1.246
Valve Pushrod	0.426
Valve Rocker Arm	0.333
Valve Rocker Arm Cover Gasket Kit	0.423
Water Pump Kit (with gasket)	1.069

**Sealers, Adhesives and Lubricants**

<b>Application</b>	<b>Type of Material</b>	<b>GM Part Number</b>
Block Heater Threads	Sealant	12346004
Camshaft Rear Bearing Hole Plug	Sealant	12377901
Coolant Sensor (ETC) Threads	Sealant	12346004
Crankshaft Position Sensor Bolt	Thread Adhesive	12345493
Crankshaft Rear Bearing Cap	Sealant	1052942
Cylinder Head Bolt Threads	Sealant	12346004
Engine Block Coolant Drain Plugs	Sealant	12346004
Engine Block Oil Gallery Plugs	Sealant	12346004
Engine Front Cover	Sealant	12346286
Engine Oil Supplement	Lubricant	1051396
Intake Manifold Bolt Threads	Thread Adhesive	12345382
Knock Sensor Threads	Sealant	12346004
MAP Sensor Seal	Lubricant	9985770
Oil Cooler Hose Fittings	Sealant	12346004
Oil Pan Corners	Sealant	12346286
Oil Pressure Sensor Threads	Sealant	12346004
Purge Solenoid Bolt	Thread Adhesive	12345493
Valve Train Component Prelube	Lubricant	1052367
Water Pump Bolt Threads	Sealant	12346004

## Diagnostic Information and Procedures

### Base Engine Misfire Diagnosis

Checks	Action
<p>Engine Performance diagnosis procedures are covered in Engine Controls and should be consulted for diagnosis of any Drivability, Emissions or Malfunctioning Indicator Lamp (MIL) concerns.</p> <p>The following diagnosis covers common concerns and possible causes.</p> <p>When the proper diagnosis is made, the concern should be corrected by adjustment, repair or replacement as required.</p> <p>Refer to the appropriate section of the service manual for each specific procedure.</p> <p>This diagnostic table will assist in engine misfire diagnosis due to a mechanical concern such as a faulty engine camshaft, worn or damaged bearings or bent valve pushrod.</p> <p>This table will not isolate a crossed fuel injector wire, faulty fuel injector or any other drivability component failure that may cause a misfire.</p> <p>The Powertrain On-Board Diagnostic System checks must be performed first.</p> <p>When using this table to make a Base Engine Misfire diagnosis, begin with the preliminary information below and then proceed to the specific category.</p>	
Preliminary	<ol style="list-style-type: none"> <li>1. Perform DTC P0300 before proceeding with Base Engine Misfire Diagnosis information. DTC P0300 will assist in determining which cylinder or cylinders are misfiring.</li> <li>2. Perform a visual inspection of the following: <ul style="list-style-type: none"> <li>• A loose or improperly installed engine flywheel or crankshaft balancer</li> <li>• Worn, damaged or misaligned accessory drive system components</li> </ul> </li> <li>3. Listen to the engine for any abnormal internal engine noises.</li> <li>4. Inspect the engine for acceptable oil pressure.</li> <li>5. Verify if the engine has excessive oil consumption.</li> <li>6. Verify if the engine has excessive coolant consumption.</li> <li>7. Perform a compression test on the engine.</li> </ol>
Intake Manifold Leaks	<p>An intake manifold that has a vacuum leak may cause a misfire.</p> <p>Inspect for the following:</p> <ul style="list-style-type: none"> <li>• Improperly installed or damaged vacuum hoses</li> <li>• Faulty or improperly installed lower intake manifold and/or gaskets</li> <li>• Cracked or damaged lower intake manifold</li> <li>• Improperly installed MAP sensor The sealing grommet of the MAP sensor should not be torn or damaged</li> <li>• Improperly installed throttle body or damaged gasket</li> <li>• Warped intake manifold</li> <li>• Warped or damaged cylinder head sealing surface</li> </ul>
Coolant Consumption	<p>Coolant consumption may or may not cause the engine to overheat.</p> <p>Inspect for the following:</p> <ul style="list-style-type: none"> <li>• External coolant leaks</li> <li>• Faulty cylinder head gasket</li> <li>• Warped cylinder head</li> <li>• Cracked cylinder head</li> <li>• Damaged engine block</li> </ul>
Oil Consumption	<p>Oil consumption may or may not cause the engine to misfire.</p> <ol style="list-style-type: none"> <li>1. Remove the spark plugs and inspect for an oil fouled spark plug.</li> <li>2. Perform a cylinder compression test.</li> <li>3. If the compression test indicates worn valves or valve guides, inspect the following: <ul style="list-style-type: none"> <li>• Worn, brittle or improperly installed valve stem oil seals</li> <li>• Worn valve guides</li> <li>• Worn valve stems</li> <li>• Worn or burnt valves or valve seats</li> </ul> </li> <li>4. If the compression test indicates worn or damaged piston rings, inspect the following: <ul style="list-style-type: none"> <li>• Broken or improperly seated piston rings</li> <li>• Excessive piston ring end gap</li> <li>• Excessive cylinder bore wear or taper</li> <li>• Cylinder damage</li> <li>• Piston damage</li> </ul> </li> </ol>



**Base Engine Misfire Diagnosis (cont'd)**

Checks	Action
Abnormal Internal Engine Noises	<ol style="list-style-type: none"> <li>1. Start the engine and determine if the noise is timed to the engine camshaft speed or the crankshaft speed.</li> <li>2. Using a timing light, two knocks per flash is the crankshaft speed and one knock per flash is the engine camshaft speed.</li> <li>3. If the noise is timed to the engine camshaft speed, inspect the following:                             <ul style="list-style-type: none"> <li>• Missing or loose valve train components</li> <li>• Worn or loose valve rocker arms</li> <li>• Worn or bent valve pushrods</li> <li>• Faulty valve springs</li> <li>• Bent or burnt valves</li> <li>• Worn engine camshaft lobes</li> <li>• Worn or damaged camshaft timing chain and/or sprockets</li> </ul> </li> </ol> <p><b>Important:</b> A slight COLD knock or piston slapping noise could be considered normal if not present after the engine has reached normal operating temperatures. If the knock is timed to the crankshaft speed, inspect the following:</p> <ul style="list-style-type: none"> <li>• Worn crankshaft or connecting rod bearings</li> <li>• Piston ro cylinder damage</li> <li>• Worn piston or piston pin</li> <li>• Faulty connecting rod</li> <li>• Excessive carbon build-up on the top of the piston</li> </ul>
No Abnormal Internal Engine Noise	<ol style="list-style-type: none"> <li>1. Inspect for a worn or improperly installed camshaft timing chain and/or sprockets.</li> <li>2. Remove the valve rocker arm cover on the side of the engine with the cylinder that is misfiring.</li> <li>3. Inspect for the following:                             <ul style="list-style-type: none"> <li>• Loose valve rocker arm studs</li> <li>• Bent valve push rods</li> <li>• Faulty valve springs</li> <li>• Faulty valve lifters (bleeding down)</li> <li>• Worn or improperly seated valves</li> <li>• Worn engine camshaft lobes</li> </ul> </li> </ol>

**Engine Compression Test**

1. Disconnect the positive ignition coil wire plug from ignition coil.
  2. Disconnect the fuel injector electrical connector.
  3. Remove all the spark plugs.
  4. Block the throttle plate wide open.
  5. Charge the battery if the battery is not fully charged.
  6. Start with the compression gauge at zero. Then crank the engine through four compression strokes (four puffs).
  7. Make the compression check the same for each cylinder. Record the reading.  
The minimum compression in any one cylinder should not be less than 70 percent of the highest cylinder. No cylinder should read less than 690 kPa (100 psi). For example, if the highest pressure in any one cylinder is 1035 kPa (150 psi), the lowest allowable pressure for any other cylinder would be 725 kPa (105 psi). (1035 x 70% = 725) (150 x 70% = 105).
  8. If some cylinders have low compression, inject approximately 15 ml (one tablespoon) of engine oil into the combustion chamber through the spark plug hole.
  9. Install the removed parts.
  10. Connect the disconnected components.
- Normal - Compression builds up quickly and evenly to the specified compression for each cylinder.
  - Piston Rings Leaking - Compression is low on the first stroke. Then compression builds up with the following strokes but does not reach normal. Compression improves considerably when you add oil.
  - Valves Leaking - Compression is low on the first stroke. Compression usually does not build up on the following strokes. Compression does not improve much when you add oil.
  - If two adjacent cylinders have lower than normal compression, and injecting oil into the cylinders does not increase the compression, the cause may be a head gasket leaking between the two cylinders.

### Engine Noise Diagnosis

Symptoms	Cause
<p>When diagnosing engine noise complaints, use the following steps to isolate the source of the engine noise:</p> <ul style="list-style-type: none"> <li>• Determine the type of noise For example, is the noise a light rattle/tapping or a low rumble/knocking?</li> <li>• The exact operating condition under which the noise exists Note factors such as ambient temperature, the amount of engine warm-up time, the engine temperature, the engine RPM and other specifics.</li> <li>• At what rate the noise occurs, and at what location on the engine Engine noises are generally synchronized to either engine speed (crankshaft, engine flywheel, connecting rods, crankshaft balancer or pistons and related components) or one-half engine speed (valve train noise such as valve rocker arms, valve lifters and camshaft timing chain). Determine the rate at which the noise is occurring.</li> <li>• Compare the engine sounds to other engines, and make sure you are not trying to correct a normal condition.</li> </ul>	
Noise on Start-Up but Only Lasts a Few seconds	<ul style="list-style-type: none"> <li>• Improper oil viscosity. Install the recommended oil viscosity for the expected temperatures.</li> <li>• Worn or dirty valve lifters</li> <li>• Excessive piston-to-cylinder bore clearance</li> <li>• Excessive piston pin-to-bore clearance</li> <li>• Excessive crankshaft bearing clearance</li> </ul>
Knocks Cold and Continues for 1 to 2 Minutes	<ul style="list-style-type: none"> <li>• Loose or broken crankshaft balancer or accessory drive components</li> <li>• Excessive piston-to-bore clearance A cold piston knock which appears in 1.5 minutes should be considered acceptable.</li> <li>• A cold engine knock usually disappears when the specific cylinders secondary ignition circuit is grounded out.</li> </ul>
Intermittent Noise on Idle, Disappearing When Engine Speed is Increased	<ul style="list-style-type: none"> <li>• Improper oil viscosity. Install the recommended oil viscosity for the expected temperatures.</li> <li>• Lower than specified oil pressure Install an oil pressure gauge and measure the engine oil pressure.</li> <li>• Dirty or worn valve lifter</li> </ul>
Valve Train Noise (Rattle/Tapping)	<p>The following conditions may cause valve train noise:</p> <ul style="list-style-type: none"> <li>• Lower than specified oil pressure</li> <li>• Worn or faulty oil pump</li> <li>• Loose oil pump-to-engine block bolt</li> <li>• Loose valve rocker arm attachments</li> <li>• Worn valve rocker arms and/or valve pushrods</li> <li>• Broken valve spring</li> <li>• Sticking valves</li> <li>• Worn, dirty or faulty valve lifters</li> <li>• Worn engine camshaft lobes</li> <li>• Worn valve guides or valve stems</li> <li>• Bent, broken or damaged timing chain sprocket teeth</li> </ul>
Knocks Hot at Idle (Rumble/Knocking)	<p>The following conditions may cause a knocking noise:</p> <ul style="list-style-type: none"> <li>• Malfunctioning accessory drive system components</li> <li>• Loose or broken crankshaft balancer</li> <li>• Detonation or spark knock Check for proper operation of the cooling, knock and ignition control components.</li> <li>• Refer to diagnostic information in Engine Controls</li> <li>• Excessive connecting rod bearing clearance</li> <li>• Excessive piston pin-to-bore clearance</li> <li>• Bent connecting rod</li> <li>• Excessive crankshaft bearing clearance</li> <li>• Loose torque converter bolts (if equipped)</li> <li>• Cracked or damaged engine flywheel</li> <li>• Exhaust leak at the exhaust manifold</li> <li>• Combustion chamber deposits</li> </ul>
Exhaust System Noise and/or Leakage	<p>Exhaust system noise and/or leakage may be caused by the following conditions:</p> <ul style="list-style-type: none"> <li>• Improperly installed or misaligned exhaust system components</li> <li>• A cracked or broken exhaust manifold</li> <li>• Damaged or worn exhaust manifold gaskets and/or seals</li> <li>• Burnt or rusted out exhaust system components</li> <li>• Broken or loose exhaust clamps and/or brackets</li> </ul>

## Valve Train Diagnosis

### General Information

Symptoms	Cause
<ul style="list-style-type: none"> <li>• A light tapping noise at 1/2 engine speed, or any varying frequency, may indicate a valve train problem.</li> <li>• Tapping noises will typically increase with increased engine speed.</li> <li>• Before attempting to diagnose a valve train noise, check for the proper engine oil level and then allow the engine to obtain normal operating temperature. Following this procedure will bring all engine components to a normal state of expansion.</li> <li>• Sit in the driver's seat, then operate the engine at various speeds and listen for any abnormal engine noise.</li> </ul>	
Valve Train Noise	<ul style="list-style-type: none"> <li>• Low engine oil pressure</li> <li>• A worn or faulty oil pump</li> <li>• A loose or plugged oil pump screen</li> <li>• Loose valve rocker arm attachments (causing excessive valve lash)</li> <li>• A worn or damaged valve rocker arm ball</li> <li>• A worn valve rocker arm and/or valve pushrod</li> <li>• A broken valve spring</li> <li>• Sticking valves</li> <li>• Valve lifters worn, dirty or faulty</li> <li>• A broken valve lifter guide</li> <li>• Engine camshaft lobes worn</li> <li>• Worn valve guides or valve stems</li> <li>• Bent valve pushrods</li> <li>• Excessive free play in the camshaft timing chain</li> <li>• Bent, broken or damaged camshaft sprocket teeth</li> </ul>

### Diagnostic Table

Step	Action	Value(s)	Yes	No
DEFINITION: A light tapping noise at 1/2 engine speed, or any varying frequency.				
1	Is there valve train noise?	—	Go to Step 2	System OK
2	Check for a high engine oil level. An engine with the engine oil level above the FULL mark on the oil level indicator allows the crankshaft counterweights to churn the engine oil into foam. When the foamy engine oil is pumped into the valve lifters, the valve lifters become noisy. A solid column of engine oil ensures proper valve lifter operation. Is the engine oil level too high?	—	Go to Step 3	Go to Step 4
3	Drain the engine oil to the proper level. Is the tapping noise gone?	—	System OK	Go to Step 6
4	Check for a low engine oil level. An engine with the engine oil level below the ADD mark on the oil level indicator may allow the oil pump to pump air at high engine RPM. Is the engine oil level below the ADD mark on the oil level indicator?	—	Go to Step 5	Go to Step 6
5	Add the engine oil as required. Is the tapping noise gone?	—	System OK	Go to Step 6
6	Check for the proper engine oil pressure. Refer to <i>Engine Mechanical Specifications</i> and <i>Oil Pressure Diagnosis and Testing</i> . Is the engine oil pressure within specifications?	41.4 kPa (6 psi)	Go to Step 11	Go to Step 7

Diagnostic Table (cont'd)

Step	Action	Value(s)	Yes	No
7	Check the oil pump screen for damage or a loose fit to the oil pump. Is the oil pump screen loose or is the oil pump screen damaged?	—	Go to Step 8	Go to Step 9
8	Repair as required. Is the tapping noise gone?	—	System OK	Go to Step 9
9	Check for a damaged oil pump or loose bolts. Refer to <i>Oil Pump Clean and Inspect</i> . Is the oil pump damaged or are the bolts loose?	—	Go to Step 10	Go to Step 11
10	Repair as required. Is the tapping noise gone?	—	System OK	Go to Step 11
11	Remove and inspect the valve lifters, the valve rocker arms and the valve pushrods. Refer to <i>Valve Rocker Arm and Pushrods Clean and Inspect</i> and <i>Valve Lifters and Guides Clean and Inspect</i> . Are the components worn or damaged?	—	Go to Step 12	Go to Step 13
12	Replace the components as required. Is the tapping noise gone?	—	System OK	Go to Step 13
13	Perform an engine camshaft lobe lift test. Refer to <i>Camshaft and Bearings Clean and Inspect</i> . Is the engine camshaft lobes within specifications?	—	Go to Step 15	Go to Step 14
14	Replace the engine camshaft and valve lifters. Is the tapping noise gone?	—	System OK	Go to Step 13
15	Remove the engine front cover and inspect the camshaft timing chain and sprockets for excessive wear or damage. Refer to <i>Timing Chain and Sprockets Clean and Inspect</i> . Are the components worn or damaged?	—	Go to Step 17	Go to Step 16
16	Replace the components as required. Is the tapping noise gone?	—	System OK	Go to Step 17
17	Perform a complete disassembly of the engine and inspect all components. Are the components worn or damaged?	—	System OK	Go to Step 11
18	Replace the components as required. Did you complete the worn or damaged component replacement?	—	System OK	—

Excessive oil consumption (not due to leaks) is the use 1.9 liters (2 quarts) of engine oil within 3,200 kilometers (2,000 miles). However, during initial engine break-in periods 4,828-6,437 kilometers (3,000-4,000 miles) oil consumption may exceed 1.9 liters (2 quarts) or more. The causes of excessive oil consumption include the following conditions:

- External oil leaks. Tighten the bolts and/or replace gaskets and oil seals as necessary.
- Incorrect oil level or improper reading of oil level indicator. With the vehicle on a level surface, allow adequate drain down time and check for the correct oil level.
- Improper oil viscosity. Use a recommended SAE viscosity for the prevailing temperatures.
- Continuous high speed operation and/or severe usage.
- Crankcase ventilation system restrictions or malfunctioning components. Possible improper PCV valve.
- Valve guides and/or valve stem oil seals worn, damaged or the seal omitted. Ream the valve guides and install oversize service valves and/or new valve stem oil seals.
- Piston rings broken, improperly installed, worn or not seated properly. Allow adequate time for the piston rings to seat. Replace broken or worn piston rings as necessary.
- Piston improperly installed or mis-fitted.

**Oil Pressure Diagnosis and Testing**

1. With the vehicle on a level surface, allow adequate drain down time (2-3 minutes) and measure for a low engine oil level.  
Add the recommended grade engine oil, and fill the crankcase until the oil level measures FULL on the oil level indicator.
2. Operate the engine and verify low or no oil pressure on the vehicle oil pressure gauge or the oil indicator light.  
Listen for a noisy valve train or a knocking noise.
3. Inspect for the following:
  - Engine oil diluted by moisture or unburned fuel mixtures
  - Improper engine oil viscosity for the expected temperature
  - Incorrect or faulty oil pressure gauge sensor
  - Incorrect or faulty oil pressure gauge
  - Plugged oil filter
  - Malfunctioning oil filter bypass valve

4. Remove the oil pressure gauge sensor or another engine block oil gallery plug.
5. Install an oil pressure gauge.
6. Start the engine and then allow the engine to reach normal operation temperature.
7. Measure the engine oil pressure at the following RPM:

**Specification**

- 7.1. 42 kPa (6psig) (minimum) at 1,000 RPM
- 7.2. 125 kPa (18 psig) (minimum) at 2,000 RPM
- 7.3. 166 kPa (24 psig) (minimum) at 4,000 RPM
8. If the engine oil pressure is below minimum specifications, inspect the engine for one or more of the following:
  - Oil pump worn or dirty
  - Malfunctioning oil pump pressure relief valve
  - Oil pump screen loose, plugged or damaged
  - Excessive bearing clearance
  - Cracked, porous or restricted oil galleries
  - Engine block oil gallery plugs missing or incorrectly installed
  - Broken valve lifters

## Oil Leak Diagnosis

Step	Action	Value(s)	Yes	No
<p><b>Important:</b> You can repair most fluid leaks by first visually locating the leak, repairing or replacing the component, or by resealing the gasket surface. Once the leak is identified, determine the cause of the leak. Repair the cause of the leak as well as the leak itself.</p>				
1	<ol style="list-style-type: none"> <li>Operate the vehicle until it reaches normal operating temperature.</li> <li>Park the vehicle on a level surface, over a large sheet of paper or other clean surface.</li> </ol>	—	Go to Step 2	System OK
2	Can you identify the type of fluid and the approximate location of the leak?	—	Go to Step 10	Go to Step 3
3	<ol style="list-style-type: none"> <li>Visually inspect the suspected area. Use a small mirror to assist in looking at hard to see areas.</li> <li>Check for leaks at the following locations: <ul style="list-style-type: none"> <li>Sealing surfaces</li> <li>Fittings</li> <li>Cracked or damaged components</li> </ul> </li> </ol> <p>Can you identify the type of fluid and the approximate location of the leak?</p>	—	Go to Step 10	Go to Step 4
4	<ol style="list-style-type: none"> <li>Completely clean the entire engine and surrounding components.</li> <li>Operate the vehicle for several kilometers (miles) at normal operating temperature and at varying speeds.</li> <li>Park the vehicle on a level surface, over a large sheet of paper or other clean surface.</li> <li>Wait (15 minutes).</li> <li>Identify the type of fluid and the approximate location of the leak.</li> </ol> <p>Can you identify the type of fluid and the approximate location of the leak?</p>	—	Go to Step 10	Go to Step 5
5	<ol style="list-style-type: none"> <li>Visually inspect the suspected area. Use a small mirror to assist in looking at hard to see areas.</li> <li>Check for leaks at the following locations: <ul style="list-style-type: none"> <li>Sealing surfaces</li> <li>Fittings</li> <li>Cracked or damaged components</li> </ul> </li> </ol> <p>Can you identify the type of fluid and the approximate location of the leak?</p>	—	Go to Step 10	Go to Step 6
6	<ol style="list-style-type: none"> <li>Completely clean the entire engine and surrounding components.</li> <li>Apply an aerosol-type powder (baby powder, foot powder, etc.) to the suspected area.</li> <li>Operate the vehicle for several kilometers (miles) at normal operating temperature and at varying speeds.</li> <li>Identify the type of fluid and the approximate location of the leak, from the discolorations in the powder surface.</li> </ol>			

**Oil Leak Diagnosis (cont'd)**

Step	Action	Value(s)	Yes	No
6	Can you identify the type of fluid and the approximate location of the leak?	—	Go to Step 10	Go to Step 4
7	1. Visually inspect the suspected area. Use a small mirror to assist in looking at hard to see areas. 2. Check for leaks at the following locations: <ul style="list-style-type: none"> <li>• Sealing surfaces</li> <li>• Fittings</li> <li>• Cracked or damaged components</li> </ul> Can you identify the type of fluid and the approximate location of the leak?	—	Go to Step 10	Go to Step 8
8	Use <i>J 28428-E</i> , Dye and Light Kit, in order to identify the type of fluid and the approximate location of the leak. Refer to manufacturer's instructions when using the tool. Can you identify the type of fluid and the approximate location of the leak?	—	Go to Step 10	Go to Step 9
9	1. Visually inspect the suspected area. Use a small mirror to assist in looking at hard to see areas. 2. Check for leaks at the following locations: <ul style="list-style-type: none"> <li>• Sealing surfaces</li> <li>• Fittings</li> <li>• Cracked or damaged components</li> </ul> Can you identify the type of fluid and the approximate location of the leak?	—	Go to Step 10	System OK
10	1. Inspect the engine for mechanical damage. Special attention should be shown to the following areas: <ul style="list-style-type: none"> <li>• Higher than recommended fluid levels</li> <li>• Higher than recommended fluid pressures</li> <li>• Plugged or malfunctioning fluid filters or pressure bypass valves</li> <li>• Plugged or malfunctioning engine ventilation system</li> <li>• Improperly tightened or damaged fasteners</li> <li>• Cracked or porous components</li> <li>• Improper sealants or gaskets where required</li> <li>• Improper sealant or gasket installation</li> <li>• Damaged or worn gaskets or seals</li> <li>• Damaged or worn sealing surfaces</li> </ul> 2. Inspect the engine for customer modifications. Is there mechanical damage, or customer modifications to the engine?	—	Go to Step 11	System OK
11	Repair or replace all damaged or modified components. Does the engine still leak oil?	—	Go to Step 1	—

## Symptoms - Drive Belt

**Important:** Review the system operation in order to familiarize yourself with the system functions. Refer to *Drive Belt System Description*.

### Visual/Physical Inspection

- Inspect for aftermarket devices which could affect the operation of the drive belts.
- Inspect the easily accessible or visible system components for obvious damage or conditions which could cause the symptom.
- Inspect the drive belt for excessive wear, shredding or missing sections.
- Inspect the drive belt for contamination of excessive dirt, oil, coolant or other substances that may affect the drive belt operation.

### Intermittent

- Drive belt symptoms may be from intermittent

failure of an accessory drive component.

- Drive belt symptoms may occur from changes in load of the accessory drive components.
- Ambient temperatures, moisture or engine operating temperature can affect the drive belt operation.

### Symptoms List

Refer to a symptom diagnostic procedure from the following list in order to diagnose the symptom:

- *Drive Belt Chirping Diagnosis*
- *Drive Belt Squeal Diagnosis*
- *Drive Belt Whine Diagnosis*
- *Drive Belt Rumbling Diagnosis*
- *Drive Belt Vibration Diagnosis*
- *Drive Belt Falls Off Diagnosis*
- *Drive Belt Excessive Wear Diagnosis*

## Drive Belt Chirping Diagnosis

### Diagnostic Aids

The symptom may be intermittent due to moisture on the drive belt(s) or the pulleys. It may be necessary to spray a small amount of water on the drive belt(s) in order to duplicate the customers concern. If spraying water on the drive belt(s) duplicates the symptom, cleaning the belt pulleys may be the probable solution.

A loose or improper installation of a body component, a suspension component or other items of the vehicle may cause the chirping noise.

### Test Description

The number(s) below refer to the step number(s) on the diagnostic table.

2. The noise may not be engine related. This step is to verify that the engine is making the noise. If the engine is not making the noise, do not proceed further with this table.
3. The noise may be an internal engine noise. Removing the drive belt and operating the engine for a brief period will verify the noise is related to the drive belt. When removing the drive belt(s), the water pump may not be operating and the engine may overheat. Also DTCs may set when the engine is operating with the drive belt removed.
4. Inspect all drive belt pulleys for pilling. Pilling is the small balls or pills or it can be strings in the drive belt grooves from the accumulation of rubber dust.

6. Misalignment of the pulleys may be caused from improper mounting of the accessory drive component, incorrect installation of the accessory drive component pulley or the pulley bent inward or outward from a previous repair. Test for a misaligned pulley using a straight edge in the pulley grooves across two or three pulleys. If a misaligned pulley is found, refer to that accessory drive component for the proper installation procedure for that pulley.
10. Inspecting of the fasteners can eliminate the possibility that a wrong bolt, nut, spacer or washer was installed.
12. Inspecting the pulleys for being bent should include inspecting for a dent or other damage to the pulleys that would prevent the drive belt from not seating properly in all of the pulley grooves or on the smooth surface of a pulley when the back side of the belt is used to drive the pulley.
14. Replacing the drive belt when it is not damaged or there is not excessive pilling will only be a temporary repair.



**Drive Belt Chirping Diagnosis**

Step	Action	Value(s)	Yes	No
<p><b>Notice:</b> Refer to <i>Belt Dressing Notice</i> in Cautions and Notices.</p> <p>DEFINITION: The following items are indications of chirping:</p> <ul style="list-style-type: none"> <li>• A high pitched noise that is heard once per revolution of the drive belt or a pulley.</li> <li>• It usually occurs on cold damp mornings.</li> </ul>				
1	Did you review the Drive Belt Symptom operation and perform the necessary inspections?	—	Go to Step 2	Go to <i>Symptoms - Drive Belt</i>
2	Verify that there is a chirping noise. Does the engine make the chirping noise?	—	Go to Step 3	Go to Diagnostic Aids
3	1. Remove the drive belt. 2. Operate the engine for no longer than 30 to 40 seconds. Does the chirping noise still exist?	—	Go to <i>Engine Noise Diagnosis</i>	Go to Step 4
4	Inspect for severe pilling exceeding 1/3 of the belt groove depth. Does the belt grooves have pilling?	—	Go to Step 5	Go to Step 6
5	Clean the drive belt pulleys with a suitable wire brush. Did you complete the repair?	—	Go to Step 15	Go to Step 6
6	Inspect for misalignment of the pulleys. Are any of the pulleys misaligned?	—	Go to Step 7	Go to Step 8
7	Replace or repair any misaligned pulleys. Did you complete the repair?	—	Go to Step 15	Go to Step 8
8	Inspect for bent or cracked brackets. Did you find any bent or cracked brackets?	—	Go to Step 9	Go to Step 10
9	Replace any bent or cracked brackets. Did you complete the repair?	—	Go to Step 15	Go to Step 10
10	Inspect for improper, loose or missing fasteners Did you find the condition?	—	Go to Step 11	Go to Step 12
11	Tighten any loose fasteners. Replace any improper or missing fasteners. Refer to <i>Fastener Tightening Specifications</i> . Did you complete the repair?	—	Go to Step 15	Go to Step 12
12	Inspect for a bent pulley. Did you find the condition?	—	Go to Step 13	Go to Step 14
13	Replace the bent pulley. Did you complete the repair?	—	Go to Step 15	Go to Step 14
14	Replace the drive belt. Refer to <i>Drive Belt Replacement</i> . Did you complete the repair?	—	Go to Step 15	Go to Diagnostic Aids
15	Operate the system in order to verify the repair. Did you correct the condition?	—	System OK	Go to Step 3

### Drive Belt Squeal Diagnosis

#### Diagnostic Aids

A loose or improper installation of a body component, a suspension component or other items of the vehicle may cause the chirping noise.

If the noise is intermittent, verify the accessory drive components by varying their loads making sure they are operated to their maximum capacity. An overcharged A/C system, power steering system with a pinched hose or wrong fluid or a generator failing are suggested items to inspect.

#### Test Description

The number(s) below refer to the step number(s) on the diagnostic table.

2. The noise may not be engine related. This step is to verify that the engine is making the noise. If the engine is not making the noise, do not proceed further with this table.
3. The noise may be an internal engine noise. Removing the drive belt and operating the engine for a brief period will verify the noise is related to the drive belt. When removing the drive belt(s), the water pump may not be operating and the engine may overheat. Also DTCs may set when the engine is operating with the drive belt removed.
4. This test is to verify that an accessory drive component does not have a seized bearing. With the belt removed, test the bearings in the

accessory drive components for turning smoothly. Also test the accessory drive components with the engine operating by varying the load on the components to verify that the components operate properly.

5. This test is to verify that the drive belt tensioner operates properly. If the drive belt tensioner is not operating properly, proper belt tension may not be achieved to keep the drive belt from slipping, which could cause a squeal noise.
6. This test is to verify that the drive belt(s) is not too long, which would prevent the drive belt tensioner from working properly. Also, if an incorrect length drive belt was installed, it may not be routed properly and may be turning an accessory drive component in the wrong direction.
7. Misalignment of the pulleys may be caused from improper mounting of the accessory drive component, incorrect installation of the accessory drive component pulley or the pulley bent inward or outward from a previous repair. Test for a misaligned pulley using a straight edge in the pulley grooves across two or three pulleys. If a misaligned pulley is found, refer to that accessory drive component for the proper installation procedure for that pulley.
8. This test is to verify that the pulleys are the correct diameter or width. Using a known good vehicle compare the pulley sizes.

### Drive Belt Squeal Diagnosis

Step	Action	Value(s)	Yes	No
<p><b>Notice:</b> Refer to <i>Belt Dressing Notice</i> in Cautions and Notices.</p> <p>DEFINITION: The following items are indications of drive belt squeal:</p> <ul style="list-style-type: none"> <li>• A loud screeching noise that is caused by a slipping drive belt (this is unusual for a drive belt with multiple ribs)</li> <li>• The noise occurs when a heavy load is applied to the drive belt, such as an air conditioning compressor engagement, snapping the throttle or slipping on a seized pulley or a faulty accessory drive component.</li> </ul>				
1	Did you review the Drive Belt Symptom operation and perform the necessary inspections?	—	Go to Step 2	Go to <i>Symptoms - Drive Belt</i>
2	Verify that there is a squeal noise. Does the engine make the squeal noise?	—	Go to Step 3	Go to Diagnostic Aids
3	1. Remove the drive belt(s). 2. Operate the engine for no longer than 30 to 40 seconds. Does the chirping noise still exist?	—	Go to <i>Engine Noise Diagnosis</i>	Go to Step 4
4	Inspect for an accessory drive component seized bearing or faulty accessory drive component. Did you find and correct the condition?	—	Go to Step 9	Go to Step 5

**Drive Belt Squeal Diagnosis (cont'd)**

Step	Action	Value(s)	Yes	No
5	Test the drive belt tensioner for proper operation. Refer to <i>Drive Belt Tensioner Diagnosis</i> . Did you find and correct the condition?	—	Go to Step 9	Go to Step 6
6	Inspect for the correct drive belt length. Refer to <i>Drive Belt Replacement</i> . Did you find and correct the condition?	—	Go to Step 9	Go to Step 7
7	Inspect for a misalignment of a pulley. Did you find and correct the condition?	—	Go to Step 9	Go to Step 8
8	Inspect for the correct pulley size. Did you find and correct the condition?	—	Go to Step 9	Go to Diagnostic Aids
9	Operate the system in order to verify the repair. Did you correct the condition?	—	System OK	Go to Step 3

**Drive Belt Whine Diagnosis**

**Diagnostic Aids**

The drive belt(s) will not cause the whine noise.

If the whine noise is intermittent, verify the accessory drive components by varying their loads making sure they are operated to their maximum capacity. An overcharged A/C system, power steering system with a pinched hose or wrong fluid or a generator failing are suggested items to inspect.

**Test Description**

The number(s) below refer to the step number(s) on the diagnostic table.

- 3. This test is to verify that the noise is being

caused by the drive belt(s) or the accessory drive components. When removing the drive belt(s), the water pump may not be operating and the engine may overheat. Also DTCs may set when the engine is operating with the drive belt(s) removed.

- 4. The inspection should include checking the drive belt tensioner and the drive belt idler pulley bearings. The drive belt(s) may have to be installed and the accessory drive components operated separately by varying their loads. Refer to the suspected accessory drive component for the proper inspection and replacement procedure.

**Drive Belt Whine Diagnosis**

Step	Action	Value(s)	Yes	No
<b>Notice:</b> Refer to <i>Belt Dressing Notice</i> in Cautions and Notices.				
DEFINITION: A high pitched continuous noise that may be caused by an accessory drive component failed bearing.				
1	Did you review the Drive Belt Symptom operation and perform the necessary inspections?	—	Go to Step 2	Go to <i>Symptoms-Drive Belt</i>
2	Verify that there is a whine noise. Does the engine make the whine noise?	—	Go to Step 3	Go to Diagnostic Aids
3	1. Remove the drive belt(s). 2. Operate the engine for no longer than 30 to 40 seconds. Does the whine noise still exist?	—	Go to <i>Engine Noise Diagnosis</i>	Go to Step 4
4	Inspect for a failed accessory drive component bearing. Did you find and repair the condition?	—	Go to Step 5	Go to Diagnostic Aids
9	Operate the system in order to verify the repair. Did you correct the condition?	—	System OK	—

**Drive Belt Rumbling Diagnosis**

**Diagnostic Aids**

Vibration from the engine operating may cause a body component or another part of the vehicle to make rumbling noise.

The drive belt(s) may have a condition that can not be seen or felt. Sometimes replacing the drive belt may be the only repair for the symptom.

If replacing the drive belt(s), completing the diagnostic table, and the noise is only heard when the drive component with a failure. Varying the load on the different accessory drive components may aid in identifying which component is causing the rumbling noise.

**Test Description**

The number(s) below refer to the step number(s) on the diagnostic table.

2. This test is to verify that the symptom is present during diagnosing. Other vehicle components may cause a similar symptom.
3. This test is to verify that the drive belt(s) is causing the rumbling noise. Rumbling noise may be confused with an internal engine noise due to the similarity in the description. Remove only one drive belt at a time if the vehicle has multiple drive belts. When removing the drive belt the water pump may not be operating and the engine may overheat. Also, DTC's may set when the engine is operating with the drive belt removed.
4. Inspecting the drive belt(s) is to ensure that it is not causing the noise. Small cracks across the ribs of the drive belt will not cause the noise. Belt separation is identified by the plies of the belt separating and may be seen at the edge of the belt, or felt as a lump in the belt.
5. Small amounts of pilling is a normal condition and acceptable. When the pilling is severe, the drive belt does not have a smooth surface for proper operation.

**Drive Belt Rumbling Diagnosis**

Step	Action	Value(s)	Yes	No
<p><b>Notice:</b> Refer to <i>Belt Dressing Notice</i> in Cautions and Notices.</p> <p>DEFINITION:</p> <ul style="list-style-type: none"> <li>• A low pitch tapping, knocking or thumping noise heard at or just above idle.</li> <li>• Heard once per revolution of the drive belt or a pulley.</li> <li>• Rumbling may be caused from:                             <ul style="list-style-type: none"> <li>- Pilling, the accumulation of rubber dust that forms small balls (pills) or strings in the drive belt pulley groove</li> <li>- The separation of the drive belt</li> <li>- A damaged drive belt</li> </ul> </li> </ul>				
1	Did you review the Drive Belt Symptom operation and perform the necessary inspections?	—	Go to Step 2	Go to <i>Symptoms-Drive Belt</i>
2	Verify that there is a rumbling noise. Does the engine make the rumbling noise?	—	Go to Step 3	Go to Diagnostic Aids
3	1. Remove the drive belt(s). 2. Operate the engine for no longer than 30 to 40 seconds. Does the rumbling noise still exist?	—	Go to <i>Engine Noise Diagnosis</i>	Go to Step 4
4	Inspect the drive belt(s) for damage, separation or sections of missing ribs. Did you find and repair the condition?	—	Go to Step 7	Go to Step 5
5	Inspect for severe pilling of more than 1/3 of the drive belt pulley grooves. Did you find severe pilling?	—	Go to Step 6	Go to Step 7
6	1. Clean the drive belt pulleys using a suitable wire brush. 2. Reinstall the drive belt. Refer to <i>Drive Belt Replacement</i> . Did you complete the repair?	—	Go to Step 8	Go to Step 7

**Drive Belt Rumbling Diagnosis (cont'd)**

Step	Action	Value(s)	Yes	No
7	Install a new drive belt. Refer to <i>Drive Belt Replacement</i> . Did you complete the replacement?	—	Go to Step 8	—
8	Operate the system in order to verify the repair. Did you correct the condition?	—	System OK	Go to Diagnostic Aids

**Drive Belt Vibration Diagnosis**

**Diagnostic Aids**

The accessory drive components can have an affect on engine vibration. Such as, but not limited to the A/C system overcharged, the power steering system restricted or the incorrect fluid or an extra load on the generator. To help identify an intermittent or an improper condition, vary the loads on the accessory drive components.

**Test Description**

The number(s) below refer to the step number(s) on the diagnostic table.

- This test is to verify that the symptom is present during diagnosing. Other vehicle components may cause a similar symptom such as the exhaust system or the drivetrain.
- This test is to verify that the drive belt(s) or accessory drive components may be causing the vibration. When removing the drive belt the water pump may not be operating and the engine may overheat. Also, DTC's may set when the engine is operating with the drive belt removed.

- The drive belt(s) may cause a vibration. While the drive belt(s) is removed, inspect the condition of the belt.
- Inspecting of the fasteners can eliminate the possibility that a wrong bolt, nut, spacer or washer was installed.
- This step should only be performed if the fan is driven by the drive belt. Inspect the engine cooling fan for bent, twisted, loose or cracked blades. Inspect the fan clutch for smoothness, ease of turning. Inspect for a bent fan shaft or bent mounting flange.
- This step should only be performed if the water pump is driven by the drive belt. Inspect the water pump shaft for being bent. Also inspect the water pump bearings for smoothness and excessive play. Compare the water pump with a known good water pump.
- Accessory drive component brackets that are bent, cracked or loose may put extra strain on that accessory component causing it to vibrate.

**Drive Belt Vibration Diagnosis**

Step	Action	Value(s)	Yes	No
<b>Notice:</b> Refer to <i>Belt Dressing Notice</i> in Cautions and Notices.				
DEFINITION:				
<ul style="list-style-type: none"> <li>The vibration is engine-speed related.</li> <li>The vibration may be sensitive to accessory load.</li> </ul>				
1	Did you review the Drive Belt Symptom operation and perform the necessary inspections?	—	Go to Step 2	Go to <i>Symptoms-Drive Belt</i>
2	Verify that the vibration is engine related. Does the engine make the vibration?	—	Go to Step 3	Go to Diagnostic Aids
3	1. Remove the drive belt(s). 2. Operate the engine for no longer than 30 to 40 seconds. Does the rumbling noise still exist?	—	Go to <i>Engine Related Vibration in Vibration and Diagnosis</i>	Go to Step 4
4	Inspect the drive belt(s) for wear, damage, debris build-up and missing drive belt ribs. Did you find any of these conditions?	—	Go to Step 5	Go to Step 6

## Drive Belt Vibration Diagnosis (cont'd)

Step	Action	Value(s)	Yes	No
5	Install a new drive belt. Refer to <i>Drive Belt Replacement</i> . Did you complete the replacement?	—	Go to Step 11	—
6	Inspect for improper, loose or missing fasteners. Did you find any of these conditions?	—	Go to Step 5	Go to Step 6
7	Tighten any loose fasteners. Replace improper or missing fasteners. Refer to <i>Fastener Tightening Specifications</i> . Did you complete the repair?	—	Go to Step 11	—
8	Inspect for damaged fan blades or bent fan clutch shaft, if the fan is belt driven. Refer to <i>Fan Clutch Replacement</i> in Engine Cooling. Did you find and correct the condition?	—	Go to Step 11	Go to Step 9
9	Inspect for bent water pump shaft, if the water pump is belt driven. Refer to <i>Water Pump Replacement (4.3L Engine)</i> in Engine Cooling. Did you find and correct the condition?	—	Go to Step 11	Go to Step 10
10	Inspect for bent or cracked brackets. Did you find and correct the condition?	—	Go to Step 11	Go to Diagnostic Aids
11	Operate the system in order to verify the repair. Did you correct the condition?	—	System OK	Go to Step 3

## Drive Belt Falls Off Diagnosis

## Diagnostic Aids

If the drive belt(s) repeatedly falls off the drive belt pulleys, this is because of pulley misalignment.

An extra load that is quickly applied and released by an accessory drive component may cause the drive belt to fall off the pulleys. Verify the accessory drive components operate properly.

If the drive belt(s) is the incorrect length, the drive belt tensioner may not keep the proper tension on the drive belt.

## Test Description

The number(s) below refer to the step number(s) on the diagnostic table.

- This inspection is to verify the condition of the drive belt. Damage may have occurred to the drive belt when the drive belt fell off. The drive belt may have been damaged, which caused the drive belt to fall off. Inspect the belt for cuts, tears, sections of ribs missing or damaged belt plies.
- Misalignment of the pulleys may be caused from improper mounting of the accessory drive

component, incorrect installation of the accessory drive component pulley or the pulley bent inward or outward from a previous repair. Test for a misaligned pulley using a straight edge in the pulley grooves across two or three pulleys. If a misaligned pulley is found, refer to that accessory drive component for the proper installation procedure of that pulley.

- Inspecting the pulleys for being bent should include inspecting for a dent or other damage to the pulleys that would prevent the drive belt from not seating properly in all of the pulley grooves or on the smooth surface of a pulley when the back side of the belt is used to drive the pulley.
- Accessory drive component brackets that are bent or cracked will let the drive belt fall off.
- Inspecting of the fasteners can eliminate the possibility that a wrong bolt, nut, spacer or washer was installed. Missing, loose or the wrong fasteners may cause pulley misalignment from the bracket moving under load. Over tightening of the fasteners may cause misalignment of the accessory component bracket.

**Drive Belt Falls Off Diagnosis**

Step	Action	Value(s)	Yes	No
<b>Notice:</b> Refer to <i>Belt Dressing Notice</i> in Cautions and Notices.				
DEFINITION: The drive belt falls off the pulleys or may not ride correctly on the pulleys.				
1	Did you review the Drive Belt Symptom operation and perform the necessary inspections?	—	Go to Step 2	Go to <i>Symptoms-Drive Belt</i>
2	Inspect for a damaged drive belt. Did you find the condition?	—	Go to Step 3	Go to Step 4
3	Install a new drive belt. Refer to <i>Drive Belt Replacement</i> . Does the drive belt continue to fall off?	—	Go to Step 4	System OK
4	Inspect for misalignment of the pulleys. Did you find and repair the condition?	—	Go to Step 12	Go to Step 5
5	Inspect for a bent or dented pulley. Did you find and repair the condition?	—	Go to Step 12	Go to Step 6
6	Inspect for a bent or cracked bracket. Did you find and repair the condition?	—	Go to Step 12	Go to Step 7
7	Inspect for improper, loose or missing fasteners. Did you find loose or missing fasteners?	—	Go to Step 8	Go to Step 9
8	Tighten any loose fasteners. Replace improper or missing fasteners. Refer to <i>Fastener Tightening Specifications</i> . Does the drive belt continue to fall off?	—	Go to Step 9	System OK
9	Test the drive belt tensioner for operating correctly. Refer to <i>Drive Belt Tensioner Diagnosis</i> . Does the drive belt tensioner operate correctly?	—	Go to Step 11	Go to Step 10
10	Replace the drive belt tensioner. Refer to <i>Drive Belt Tensioner Replacement</i> . Does the drive belt continue to fall off?	—	Go to Step 11	System OK
11	Inspect for failed drive belt idler and drive belt tensioner pulley bearings. Did you find and repair the condition?	—	Go to Step 12	Go to Diagnostic Aids
12	Operate the system in order to verify the repair. Did you correct the condition?	—	System OK	Go to Step 2

**Drive Belt Excessive Wear Diagnosis**

**Diagnostic Aids**

Excessive wear on a drive belt(s) is usually caused by an incorrect installation or the wrong drive belt for the application.

Minor misalignment of the drive belt pulleys will not cause excessive wear, but will probably cause the drive belt(s) to make a noise or to fall off.

Excessive misalignment of the drive belt pulleys will cause excessive wear but may also make the drive belt(s) fall off.

**Test Description**

The number(s) below refer to the step number(s) on the diagnostic table.

- This inspection is to verify the drive belt(s) is correctly installed on all of the drive belt pulleys. Wear on the drive belt(s) may be caused by mis-positioning the drive belt(s) by one groove on a pulley.
- The installation of a drive belt that is too wide or too narrow will cause wear on the drive belt. The drive belt ribs should match all of the grooves on all of the pulleys.
- This inspection is to verify the drive belt(s) is not contacting any parts of the engine or body while the engine is operating. There should be sufficient clearance when the drive belt accessory drive components load varies. The drive belt(s) should not come in contact with an engine or a body component when snapping the throttle.

**Drive Belt Excessive Wear Diagnosis**

Step	Action	Value(s)	Yes	No
<b>Notice:</b> Refer to <i>Belt Dressing Notice</i> in Cautions and Notices. DEFINITION: Wear at the outside ribs of the drive belt due to an incorrectly installed drive belt.				
1	Did you review the Drive Belt Symptom operation and perform the necessary inspections?	—	Go to Step 2	Go to <i>Symptoms-Drive Belt</i>
2	Inspect the drive belt(s) for the proper installation. Refer to <i>Drive Belt Replacement</i> . Did you find the condition?	—	Go to Step 5	Go to Step 3
3	Inspect for the proper drive belt. Did you find this condition?	—	Go to Step 5	Go to Step 4
4	Inspect for the drive belt rubbing against a bracket, hose or wiring harness. Did you find and repair the condition?	—	Go to Step 6	Go to Diagnostic Aids
5	Replace the drive belt. Refer to <i>Drive Belt Replacement</i> . Did you complete the replacement?	—	Go to Step 6	—
6	Operate the system in order to verify the repair. Does the drive belt continue to fall off?	—	System OK	—

**Drive Belt Tensioner Diagnosis**

**Inspection Procedure**

**Important**

When the engine is operating the drive belt tensioner arm will move. Do not replace the drive belt tensioner because of movement in the drive belt tensioner arm.

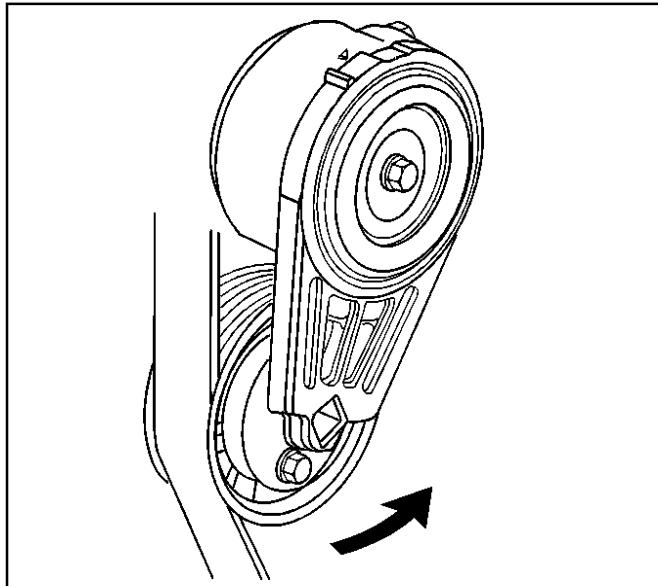

374176

2. Position a 3/8 inch drive wrench on the drive belt tensioner arm and rotate the arm counterclockwise.
3. Move the drive belt tensioner through it's full travel.
  - The movement should feel smooth
  - There should be no binding
  - The tensioner should return freely
4. If any binding is observed, replace the drive belt tensioner. Refer to *Drive Belt Tensioner Replacement*.
5. Install the drive belt. Refer to *Drive Belt Replacement*.

**Notice:** Allowing the drive belt tensioner to snap into the free position may result in damage to the tensioner.

1. Remove the drive belt. Refer to *Drive Belt Replacement*.





## Component Locator

## Dissassembled Views

## Engine Flywheel and Flywheel Housing Components

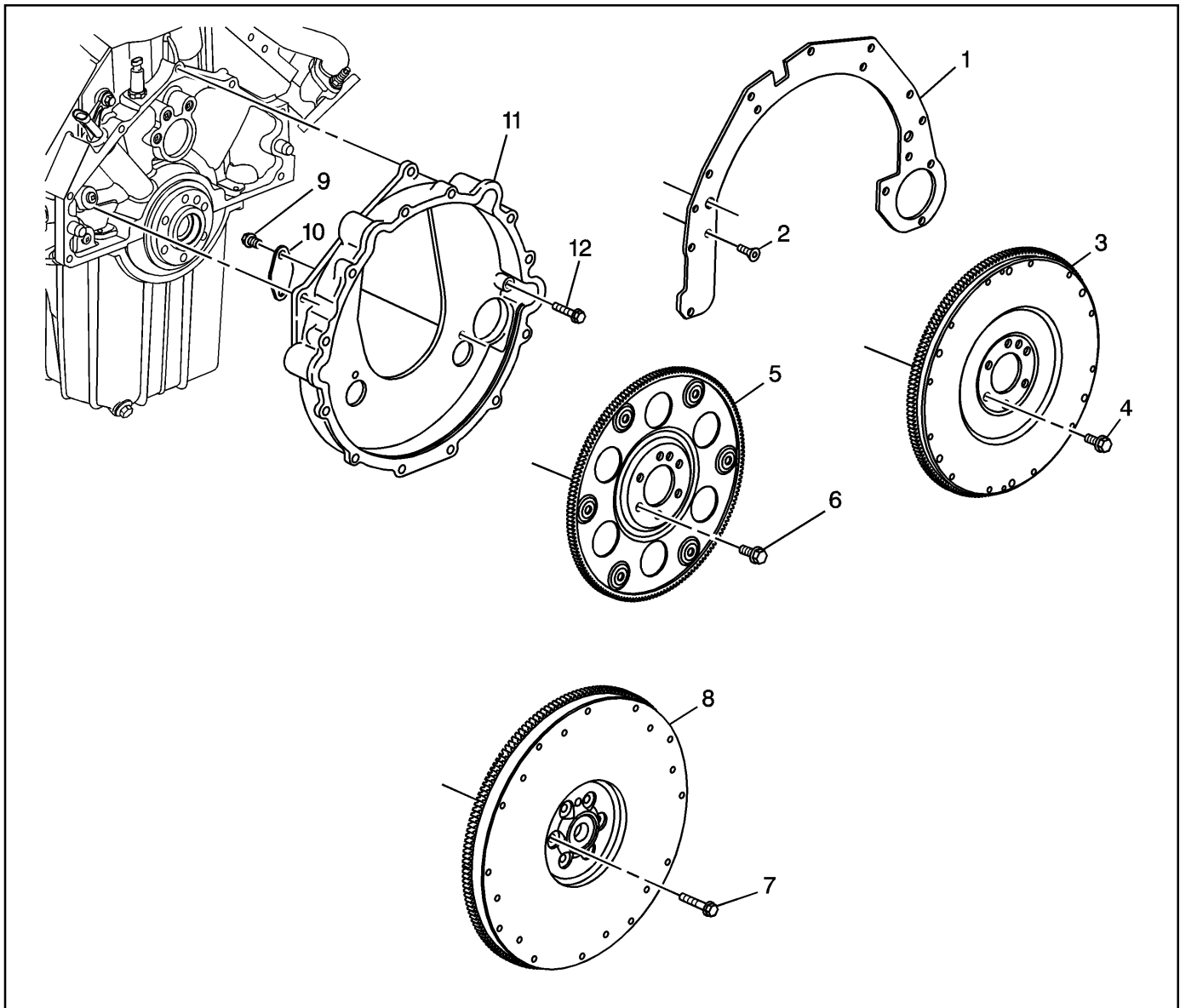

638592

## Legend

- |  |   |
|--|---|
| (1) Flywheel Housing Adapter, Medium Duty with Manual Transmission | (8) Flywheel - Medium Duty with Manual Transmission             |
| (2) Flywheel Adapter Bolt  | (9) Transmission Converter Cover                                |
| (3) Flywheel - C/K/C3500HD with Manual Transmission                | (10) Transmission Converter Cover Bolt                          |
| (4) Flywheel Bolt  | (11) Flywheel Housing - Medium Duty with Automatic Transmission |
| (5) Flywheel - Automatic Transmission                              | (12) Flywheel Housing Adapter Bolt                              |
| (6) Flywheel Bolt  |   |
| (7) Flywheel Bolt  |   |

Cylinder Head and Components

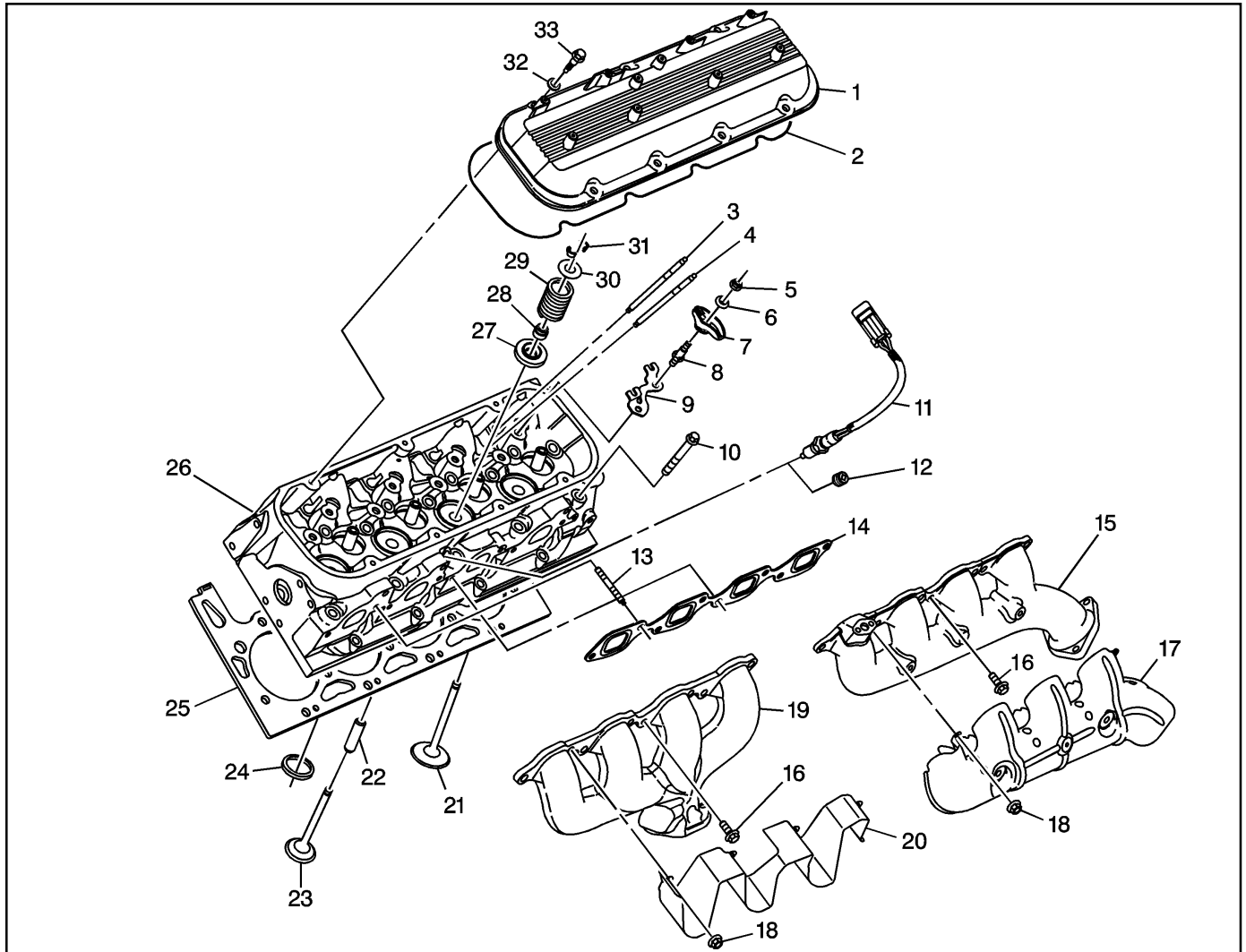

638596

Legend

- |  |   |
|--|---|
| (1) Valve Rocker Arm Cover                                       | (17) Heat Shield - C/K/C3500HD          |
| (2) Valve Rocker Arm Cover Gasket                                | (18) Heat Shield Nut                    |
| (3) Intake Valve Push Rod  | (19) Exhaust Manifold - Medium Duty     |
| (4) Exhaust Valve Push Rod                                       | (20) Heat Shield - Medium Duty          |
| (5) Valve Rocker Arm Nut   | (21) Intake Valve                       |
| (6) Valve Rocker Arm Ball  | (22) Exhaust Valve                      |
| (7) Valve Rocker Arm   | (23) Exhaust Valve Seat                 |
| (8) Valve Rocker Arm Stud  | (24) Cylinder Head Gasket               |
| (9) Push Rod Guide   | (25) Cylinder Head                      |
| (10) Cylinder Head Bolt  | (26) Valve Guide                        |
| (11) Engine Coolant Temperature (ECT) Sensor-Right Cylinder Head | (27) Valve Rotator                      |
| (12) Coolant Hole Plug-Left Cylinder Head                        | (28) Valve Stem Oil Seal                |
| (13) Exhaust Manifold Stud                                       | (29) Valve Spring                       |
| (14) Exhaust Manifold Gasket                                     | (30) Valve Spring Retainer              |
| (15) Exhaust Manifold - C/K/C3500HD                              | (31) Valve Keys                         |
| (16) Exhaust Manifold Bolt                                       | (32) Valve Rocker Arm Cover Bolt Gasket |
|  | (33) Valve Rocker Arm Cover Bolt        |

Intake Manifold and Components

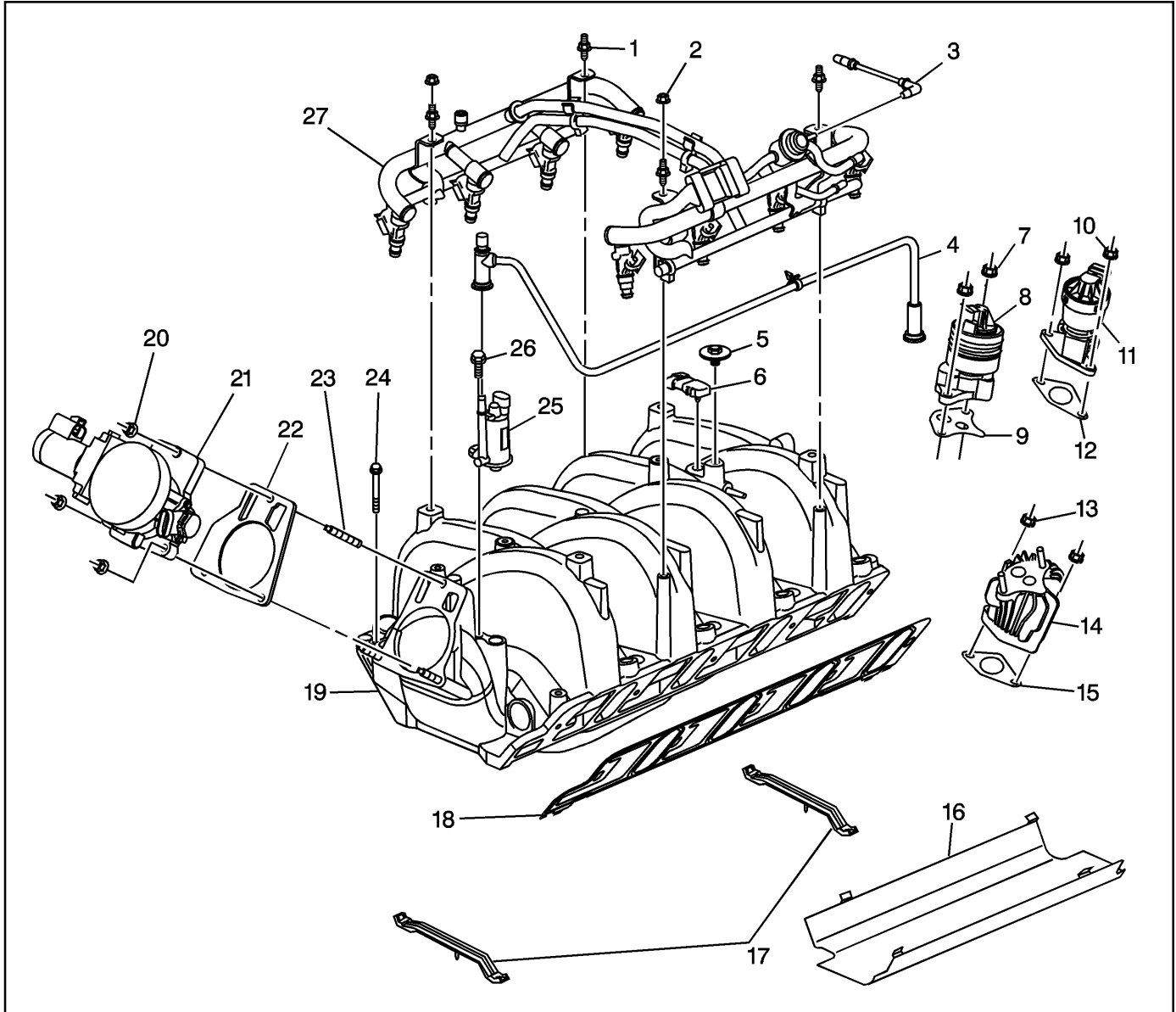

638602

Legend

- |  |   |
|--|---|
| (1) Fuel Rail Bolts                        | (15) EGR Adapter Gasket (C/K/C3500HD/Medium Duty) |
| (2) Fuel Rail Nuts                         | (16) Splash Shield                                |
| (3) Fuel Pressure Regulator Vacuum Hose    | (17) Intake Manifold End Gaskets                  |
| (4) Purge Solenoid Vacuum Hose             | (18) Intake Manifold Side Gaskets                 |
| (5) MAP Sensor Retaining Bolt              | (19) Intake Manifold                              |
| (6) MAP Sensor                             | (20) Throttle Body Nuts                           |
| (7) EGR Valve Nuts                         | (21) Throttle Body                                |
| (8) EGR Valve (C/K/C3500HD/Medium Duty)    | (22) Throttle Body Gasket                         |
| (9) EGR Valve Gasket                       | (23) Throttle Body Studs                          |
| (10) EGR Valve Nuts                        | (24) Intake Manifold Bolts                        |
| (11) EGR Valve (G Van)                     | (25) Purge Solenoid                               |
| (12) EGR Valve Gasket (G Van)              | (26) Purge Solenoid Bolt                          |
| (13) EGR Adapter Nuts                      | (27) Fuel Rail                                    |
| (14) EGR Adapter (C/K/C3500HD/Medium Duty) |   |

Engine Crankshaft and Components

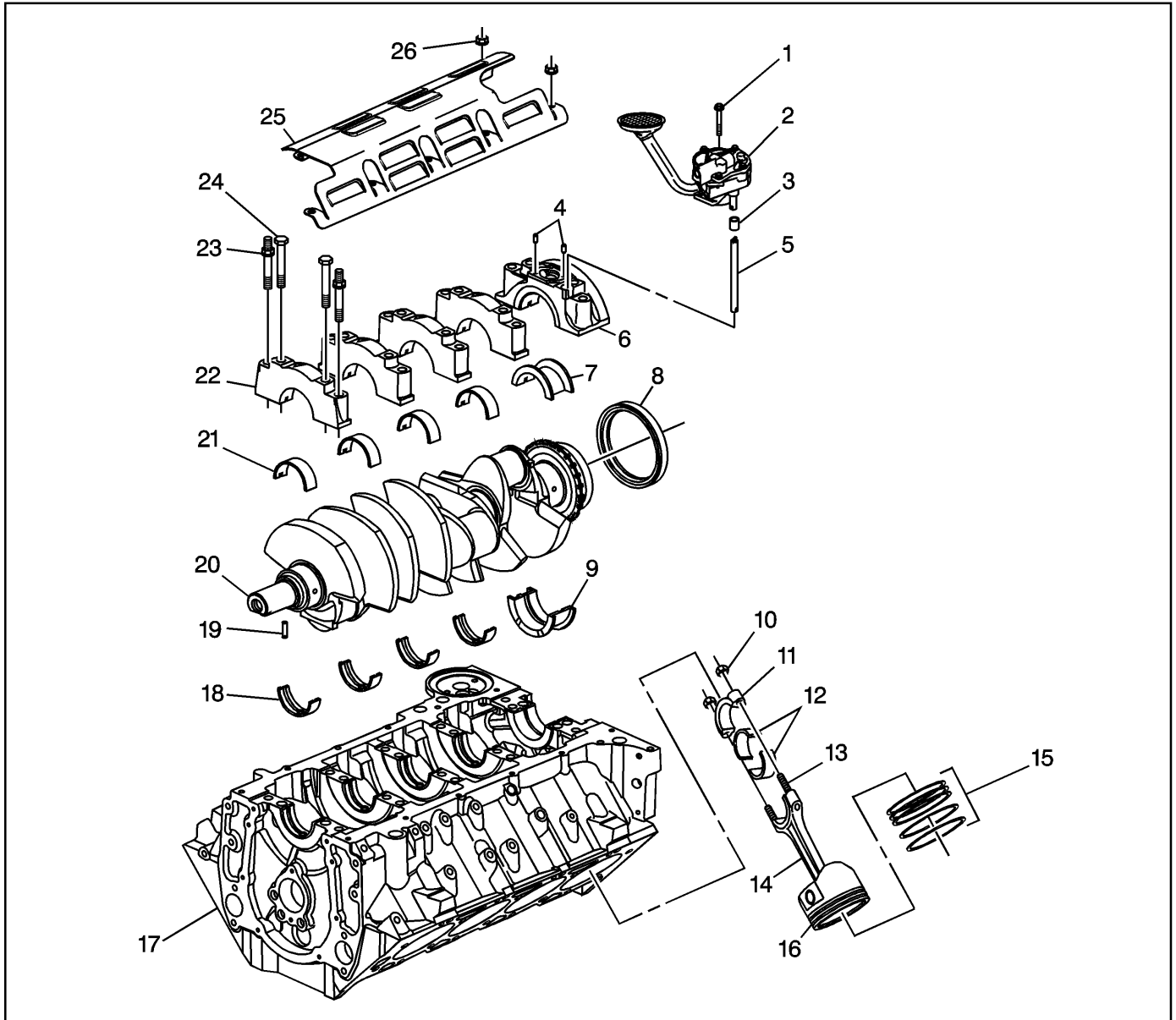

638608

Legend

- |                                      |   |
|--------------------------------------|---|
| (1) Oil Pump Screen                  | (14) Connecting Rod Bolt                |
| (2) Oil Pump Bolt                    | (15) Connecting Rod                     |
| (3) Oil Pump                         | (16) Piston Rings                       |
| (4) Oil Pump Driveshaft Retainer     | (17) Piston                             |
| (5) Oil Pump Locating Pins           | (18) Engine Block                       |
| (6) Oil Pump Driveshaft              | (19) Crankshaft Upper Bearings          |
| (7) Crankshaft Thrust Bearing Cap    | (20) Crankshaft                         |
| (8) Lower Crankshaft Thrust Bearing  | (21) Crankshaft Lower Bearings          |
| (9) Rear Crankshaft Seal             | (22) Crankshaft Bearing Caps            |
| (10) Upper Crankshaft Thrust Bearing | (23) Crankshaft Bearing Cap Outer Studs |
| (11) Connecting Rod Nut              | (24) Crankshaft Bearing Cap Inner Bolts |
| (12) Connecting Rod Cap              | (25) Oil Deflector                      |
| (13) Connecting Rod Bearings         | (26) Oil Deflector Nuts                 |

Lower Engine Block and Components

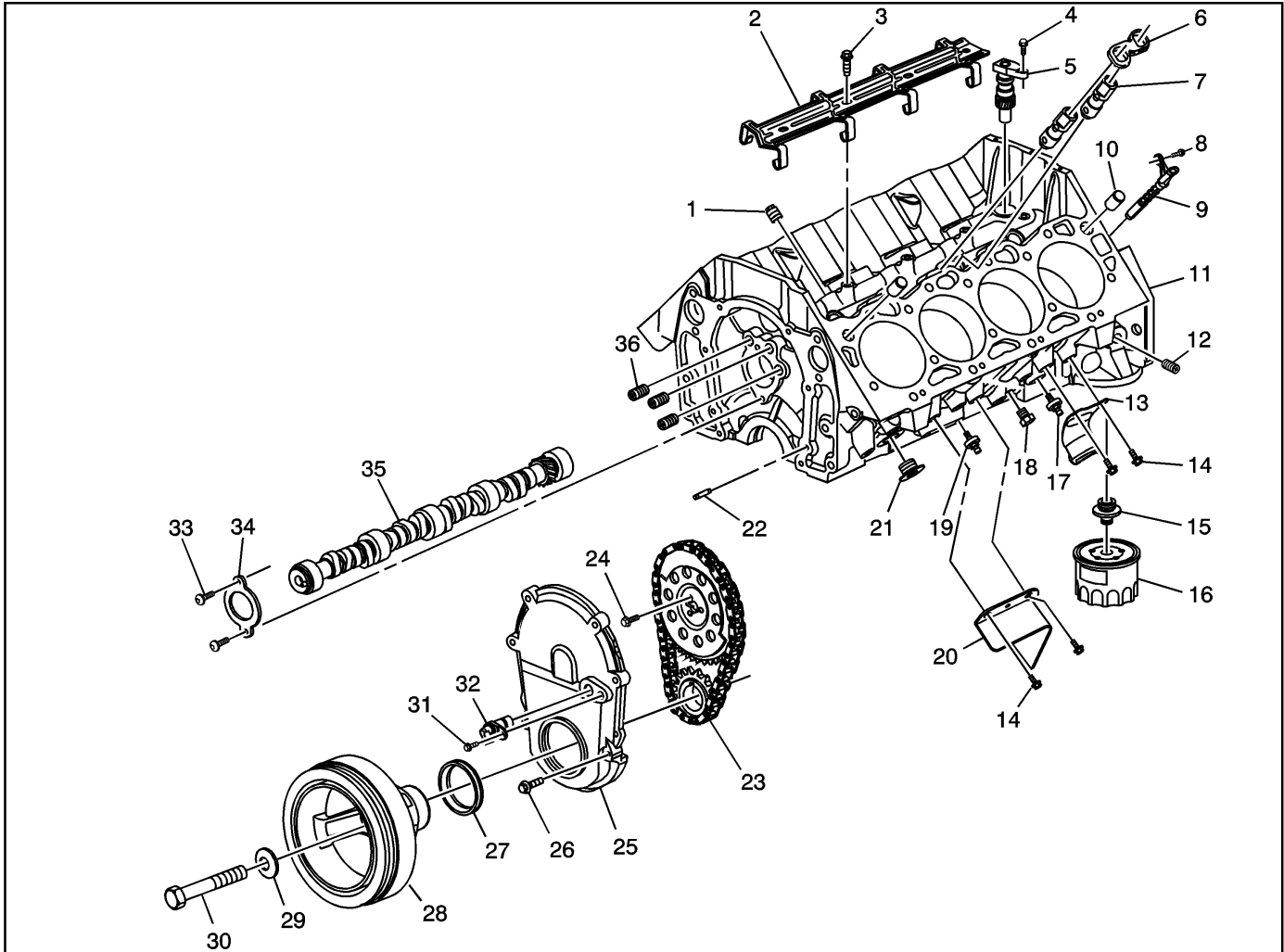

638616

Legend

- |   |   |
|---|---|
| (1) Top Oil Gallery Plug                    | (19) Left Knock Sensor - Medium Duty        |
| (2) Valve Lifter Guide Retainer             | (20) Left Knock Sensor Shield - Medium Duty |
| (3) Valve Lifter Guide Retainer Bolt        | (21) Coolant Hole Plug                      |
| (4) Oil Pump Drive Bolt                     | (22) Front Engine Cover Locating Pin        |
| (5) Oil Pump Drive                          | (23) Timing Chain Set                       |
| (6) Valve Lifter Guide                      | (24) Camshaft Sprocket Bolt                 |
| (7) Valve Lifter                            | (25) Front Engine Cover                     |
| (8) Crankshaft Position Sensor Bolt         | (26) Front Engine Cover Bolt                |
| (9) Crankshaft Position Sensor              | (27) Front Crankshaft Oil Seal              |
| (10) Cylinder Head Locating Pin             | (28) Crankshaft Balancer                    |
| (11) Engine Block                           | (29) Crankshaft Balancer Washer             |
| (12) Left Oil Gallery Plug                  | (30) Crankshaft Balancer Bolt               |
| (13) Left Knock Sensor Shield - C/K/C3500HD | (31) Camshaft Position Sensor Bolt          |
| (14) Left Knock Sensor Shield Bolt          | (32) Camshaft Position Sensor               |
| (15) Oil Filter Adapter                     | (33) Camshaft                               |
| (16) Oil Filter                             | (34) Camshaft Retainer Bolt                 |
| (17) Left Knock Sensor - C/K/C3500HD        | (35) Camshaft Retainer                      |
| (18) Coolant Drain Plug                     | (36) Front Oil Gallery Plug                 |

## Engine Identification

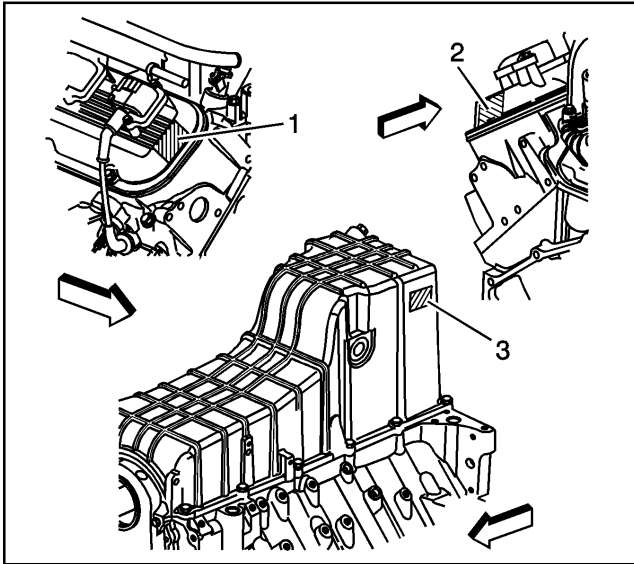

677764

The engine identification number is located on three locations. There is a label on the front of the right rocker arm cover (1), the rear of the left rocker arm cover (2) and a label on the right side of the engine oil pan (3). The engine identification number is used to track and distinguish the engine prior to installation in a vehicle.

The Vehicle Identification Number (VIN) Derivative is located on the left rear side of the engine block and is a nine digit number stamped or laser etched onto the engine at the vehicle assembly plant. If reading the identification number from the left, the following information can be obtained:

- The first digit identifies the division.
- The second digit identifies the model year.
- The third digit identifies the assembly plant.
- The fourth through ninth digits are the last six digits of the Vehicle Identification Number (VIN).

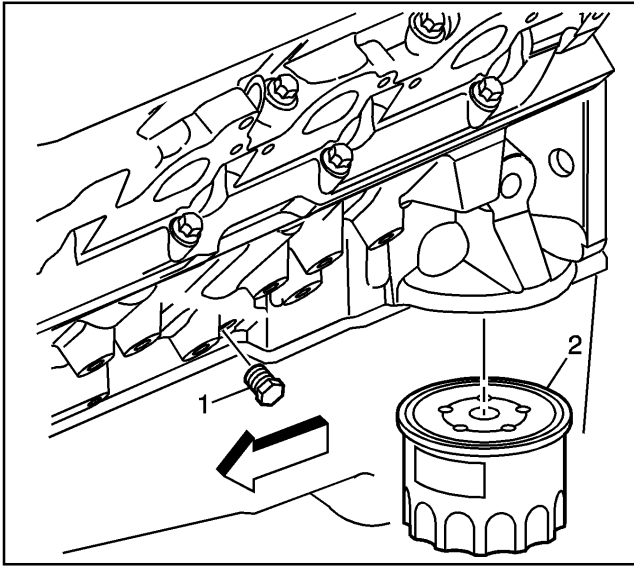

470515

## Repair Instructions

### Draining Fluids and Oil Filter Removal

1. Remove the oil pan drain plug.
2. Drain the engine oil.
3. Remove the oil filter (2).
4. Remove the left engine coolant drain hole plug (1) and the right engine coolant drain hole plug.
5. Drain the engine coolant.

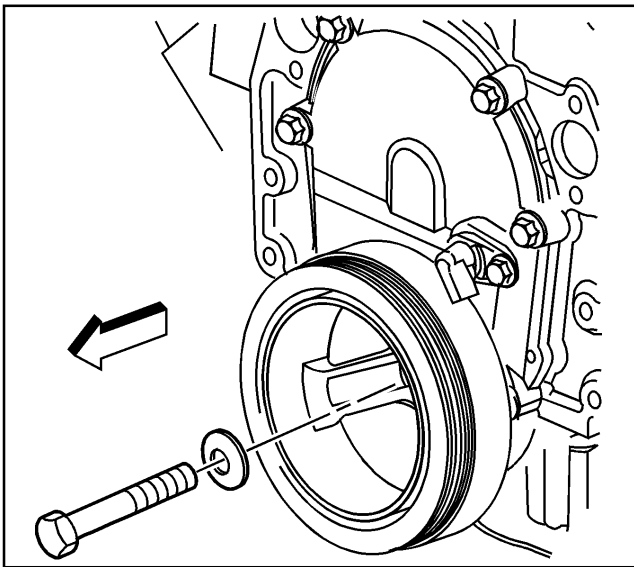

470799

### Crankshaft Balancer Removal

#### Tools Required

- J 38416 Three Jaw Puller
- J 42846 Crankshaft Protector Button
- J 42847 Flywheel Holding Tool

**Notice:** Refer to *Fastener Notice* in Cautions and Notices.

**Important:** Make sure the teeth of the flywheel holding tool engage the engine flywheel teeth.

1. Install the J 42847 to the starter bolt holes.

#### Tighten

Tighten the J 42847 bolts to 50 N·m (37 lb ft).

2. Remove the crankshaft balancer bolt and washer.

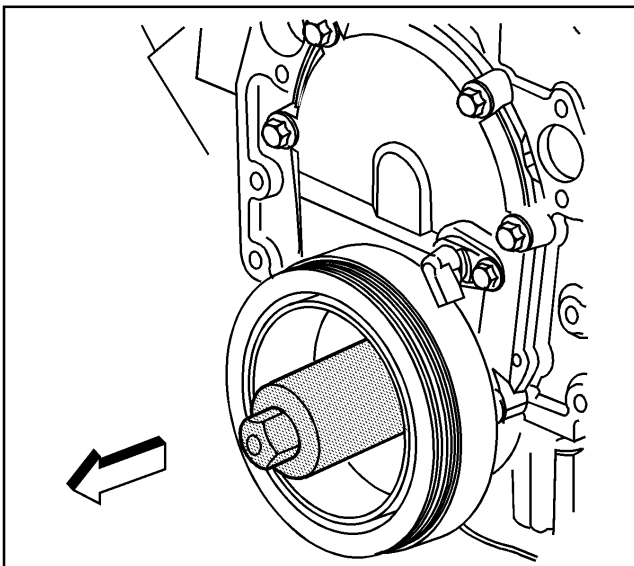

640013

3. Install the J 42846 onto the end of the crankshaft.



4. Install the J 38416 (2) in order to remove the crankshaft balancer. Place the legs of the J 38416 into the recesses cast into the backside of the balancer inner hub.
5. Tighten the center screw of the J 38416 until the crankshaft balancer is clear of the crankshaft nose.

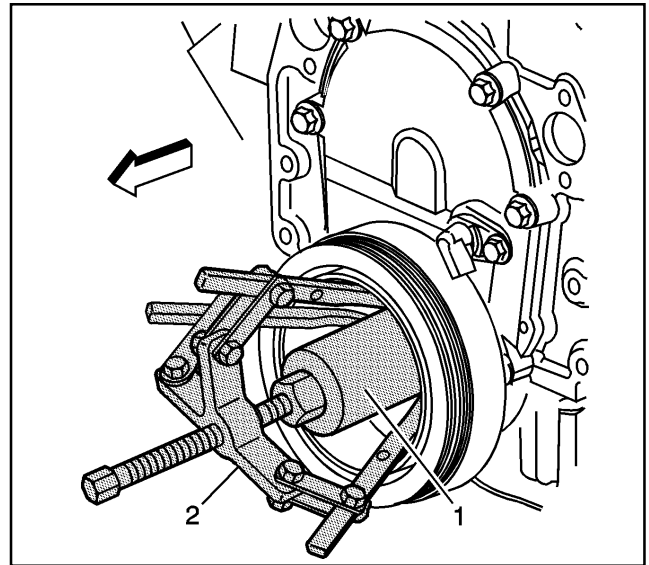

640014

6. Remove the J 38416.
7. Remove the crankshaft balancer.
8. Remove the J 42846 from the end of the crankshaft.
9. Remove the J 42847.

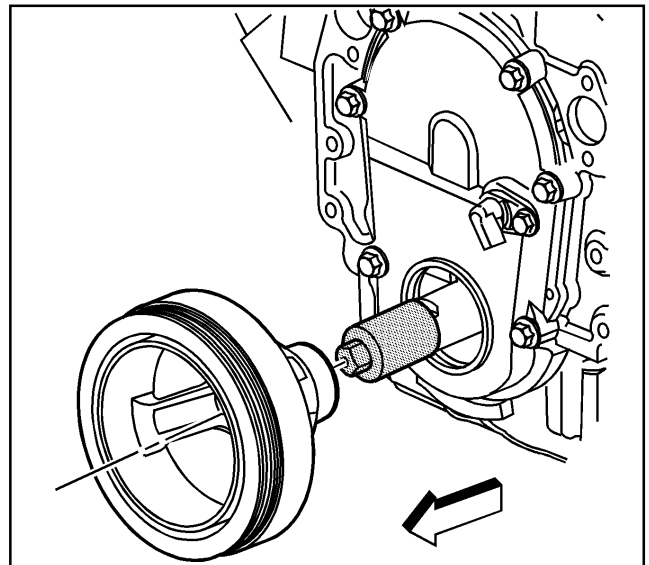

640015

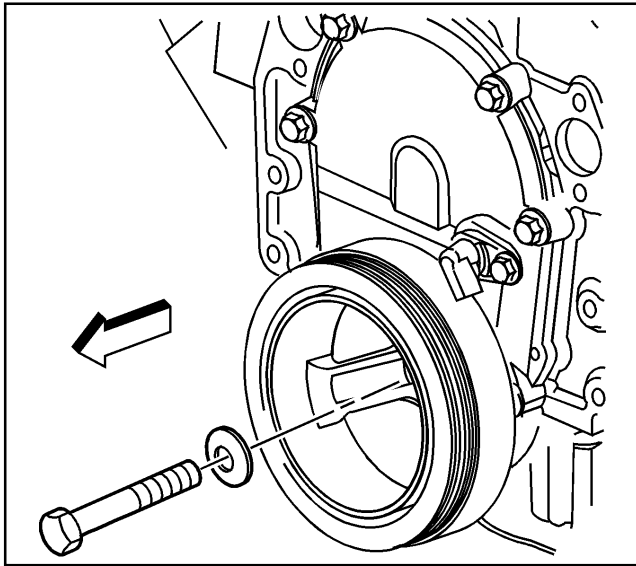

470799

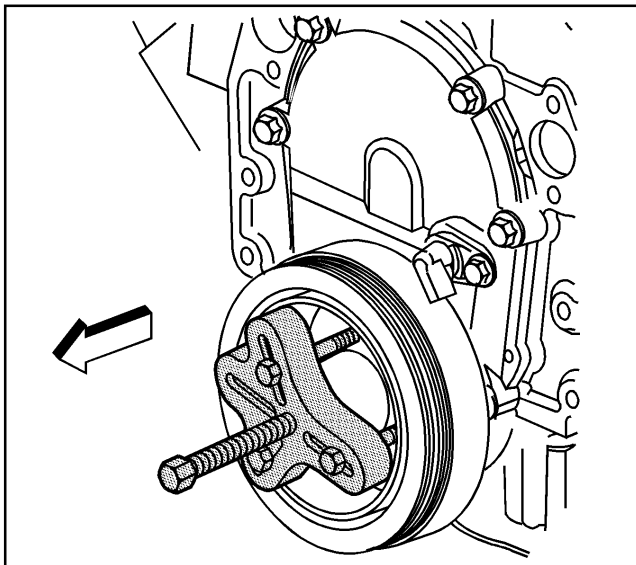

677814

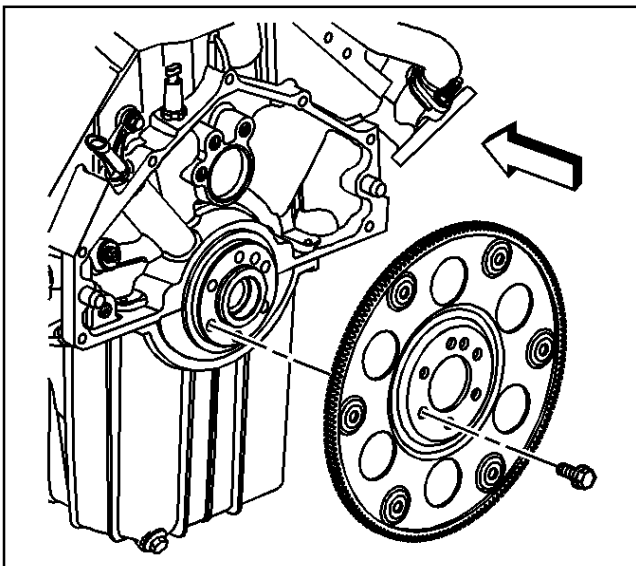

470572

## Crankshaft Balancer Removal (Medium Duty)

### Tools Required

J 24420-C Harmonic Balancer Puller

J 42847 Flywheel Holding Tool

**Notices:** Refer to *Fastener Notice* in Cautions and Notices.

**Important:** Make sure the teeth of the flywheel holding tool engage the engine flywheel teeth.

1. Install the J 42847 to the starter bolt holes.

### Tighten

Tighten the J 42847 bolts to 50 N·m (37 lb ft).

2. Remove the crankshaft balancer bolt and washer.

3. Install the J 24420-C or equivalent onto the crankshaft balancer.
4. Tighten the center screw of the J 24420-C until the crankshaft balancer is clear of the crankshaft nose.
5. Remove the crankshaft balancer.
6. Remove the J 42847.

## Engine Flywheel Removal (C/K/C3500HD with AT MT1)

1. Remove the engine flywheel bolts.
2. Remove the engine flywheel.

**Engine Flywheel Removal (C/K with MT)**

**Important:** The flywheel may need to be tapped with a non-metallic mallet from the engine side due to a slight interference fit to the crankshaft.

1. Remove the engine flywheel bolts.
2. Remove the engine flywheel.

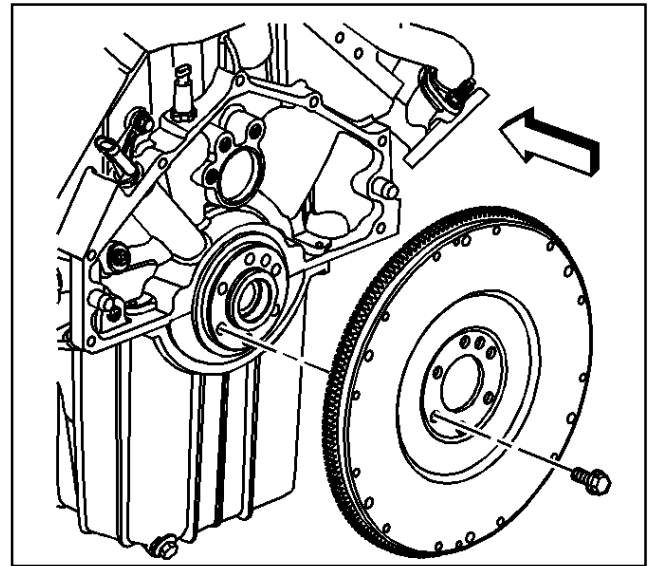

470576

**Engine Flywheel Removal (C3500HD with AT M74)**

1. Remove the engine flywheel bolts.
2. Remove the outer engine flywheel retainer.
3. Remove the engine flywheel.
4. Remove the inner engine flywheel retainer.

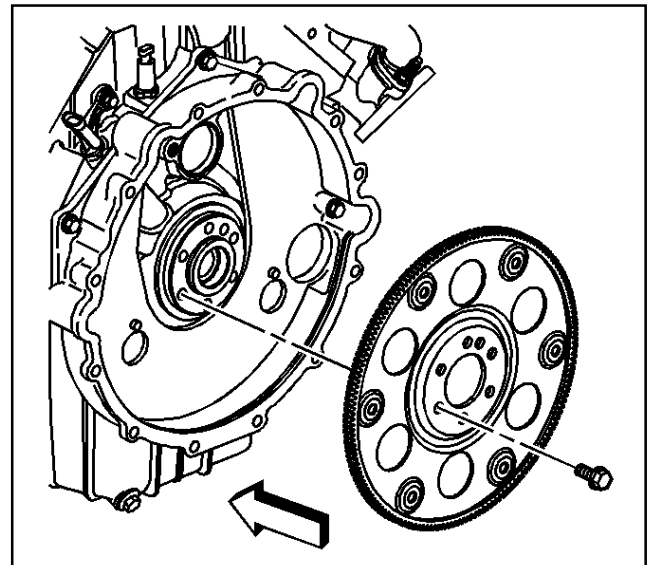

470579

**Engine Flywheel Removal (Medium Duty with MT)**

1. Remove the engine flywheel bolts.
2. Remove the engine flywheel.

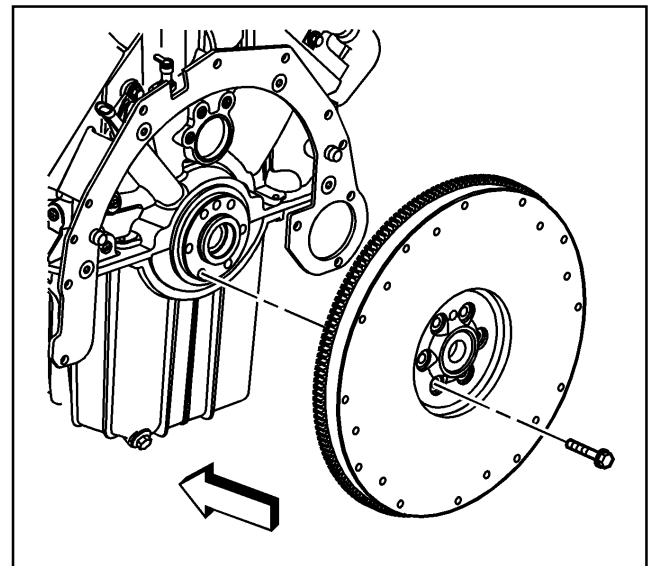

679414

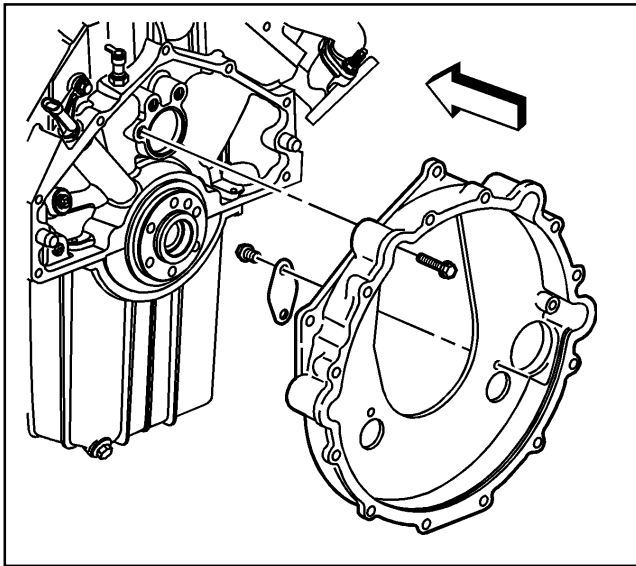

470599

### Engine Flywheel Housing Removal (Medium Duty with AT)

1. Remove the engine flywheel housing bolts.
2. Remove the engine flywheel housing.
3. Remove the transmission converter cover bolt.
4. Remove the transmission converter cover.

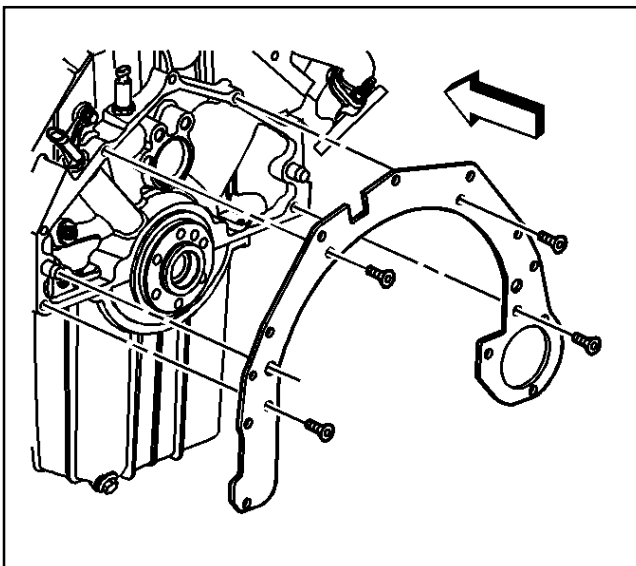

470612

### Engine Flywheel Housing Removal (Medium Duty with MT)

1. Remove the engine flywheel housing adapter bolts.
2. Remove the engine flywheel housing adapter.

**Clutch Pilot Bearing Removal (C/K/C3500HD)****Tools Required**

J 43276 Clutch Pilot Bearing Remover

**Caution:** *Wear safety glasses in order to avoid eye damage.*

**Notice:** When using the J 43276 Clutch Pilot Bearing Remover, always secure the J 43276-1 Clutch Pilot Bearing Remover tool body using a wrench. Do not allow the J 43276-1 Clutch Pilot Bearing Remover tool body to rotate. Failing to do so will cause damage to the J 43276-1 Clutch Pilot Bearing remover tool body.

1. Remove the clutch pilot bearing using the J 43276.
  - 1.1. Install the J 43276-1 tool body into the clutch pilot bearing.
  - 1.2. Using a wrench, secure the J 43276-1 tool body.
  - 1.3. Insert the J 43276-2 forcing screw into the J 43276-1 tool body.
  - 1.4. Rotate the J 43276-2 forcing screw clockwise into the J 43276-1 tool body until the clutch pilot bearing is completely removed from the crankshaft.
  - 1.5. Rotate the J 43276-2 forcing screw counterclockwise to remove the J 43276-2 forcing screw from the J 43276-1 tool body.
  - 1.6. Remove the J 43276-1 tool body from the clutch pilot bearing.
2. Discard the clutch pilot bearing.

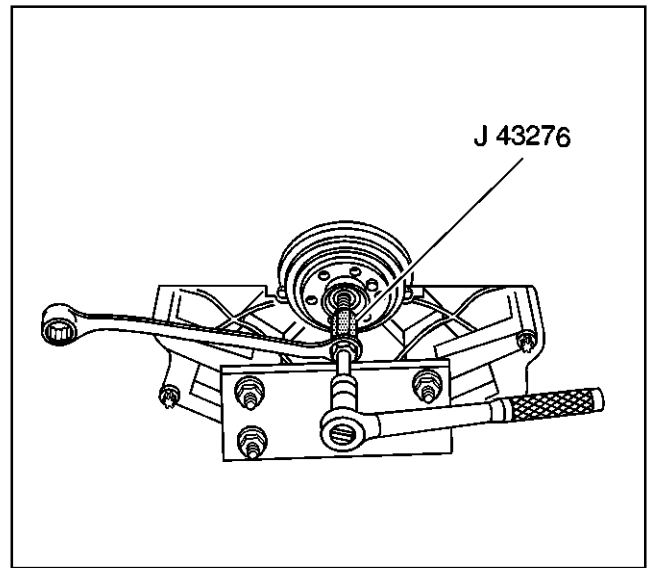

373133

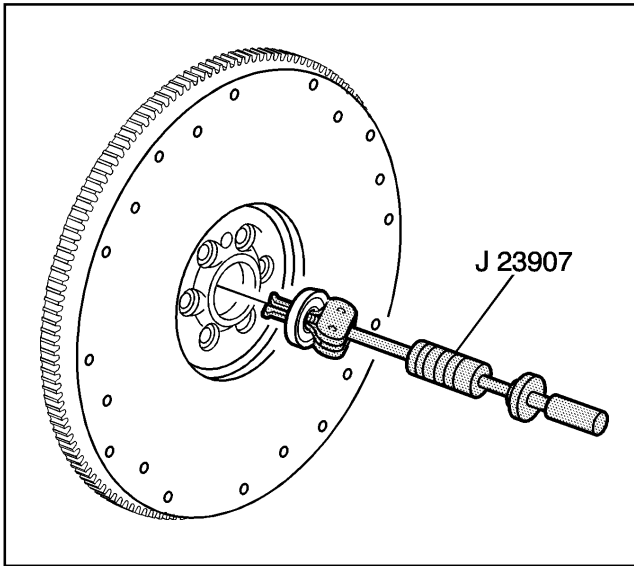

375105

### Clutch Pilot Bearing Removal (Medium Duty)

#### Tools Required

J 23907 Slide Hammer

**Caution:** Wear safety glasses in order to avoid eye damage.

1. Remove the clutch pilot bearing using the J 23907.
2. Discard the clutch pilot bearing.
3. Inspect the engine flywheel clutch pilot bearing bore for servicability.

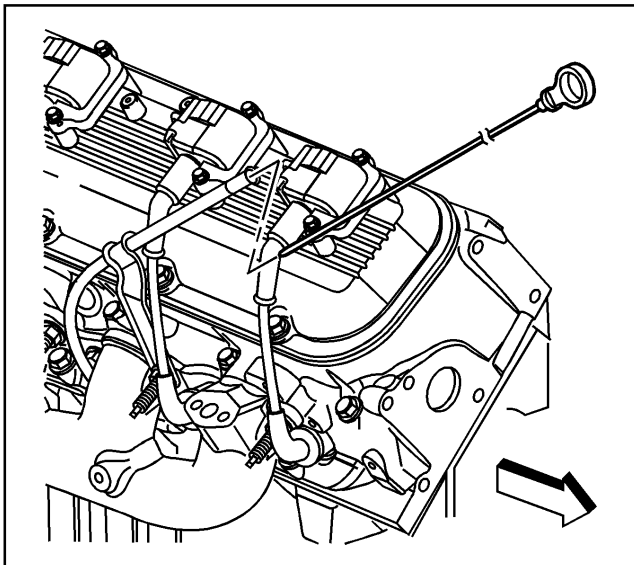

470627

### Oil Level Indicator and Tube Removal (C/K/C3500HD)

1. Remove the oil level indicator from the oil level indicator tube.

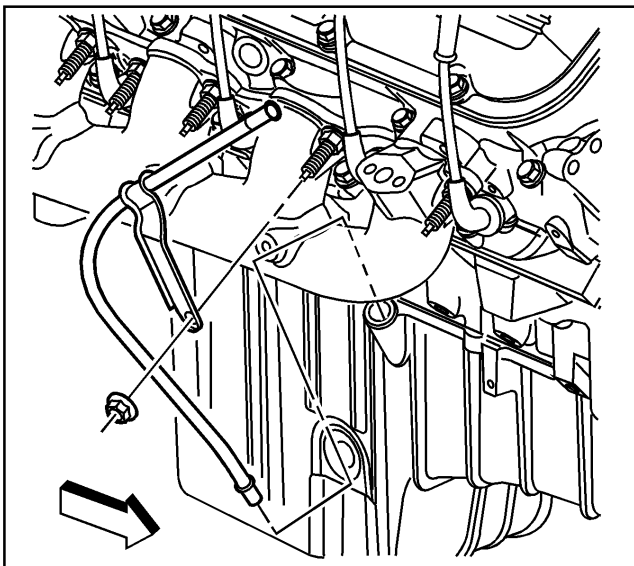

470630

2. Remove the oil level indicator tube bracket nut from the exhaust manifold stud.
3. Remove the oil level indicator tube bracket from the exhaust manifold stud.
4. Remove the oil level indicator tube from the oil pan.
5. Remove the O-ring seal from the oil level indicator tube.

**Oil Level Indicator and Tube Removal (G)**

1. Remove the oil level indicator tube bracket nut from the exhaust manifold stud.
2. Remove the oil level indicator tube bracket from the exhaust manifold stud.
3. Remove the oil level indicator tube from the oil pan.
4. Remove the O-ring seal from the oil level indicator tube.

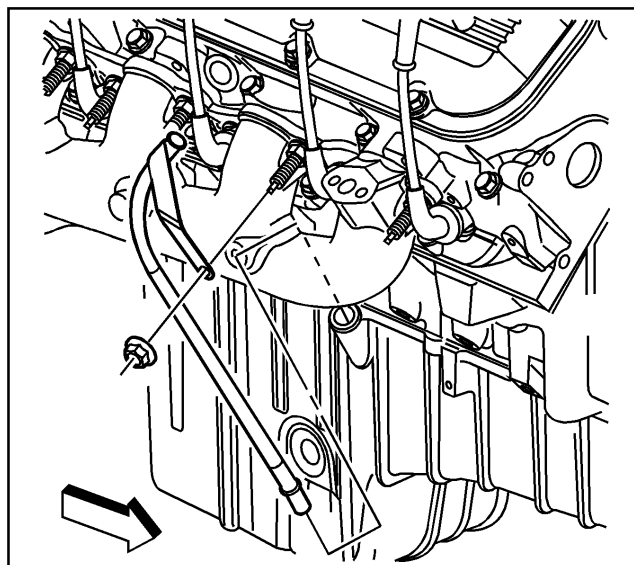

470639

**Exhaust Manifold Removal - Left**

**Important:** Twist the spark plug boot one-half turn in order to release the boot. Pull on the spark plug boot only. Do not pull on the spark plug wire or the wire could be damaged.

1. Remove the left spark plug wires from the spark plugs and ignition coils.

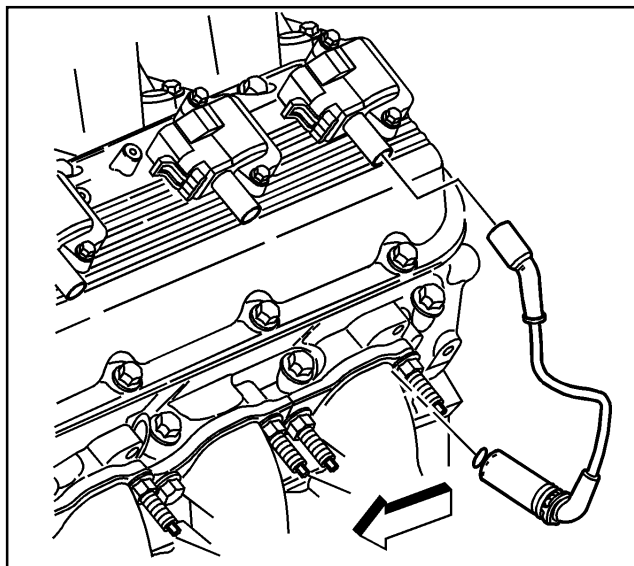

470666

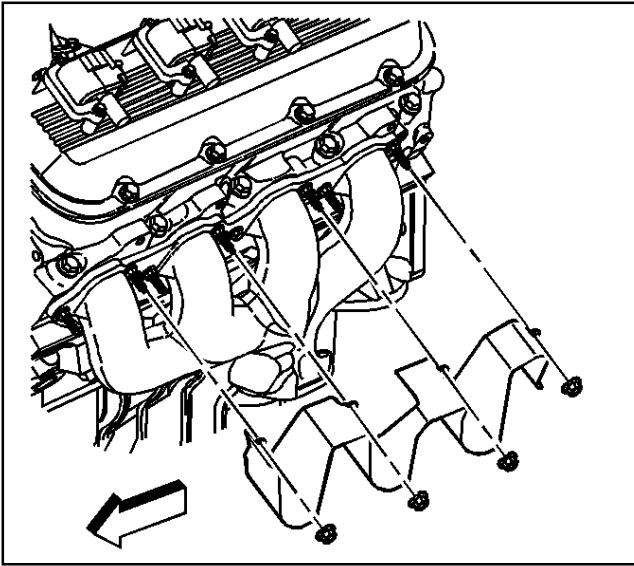

470678

2. Remove the left exhaust manifold heat shield nuts.
3. Remove the left exhaust manifold heat shield.

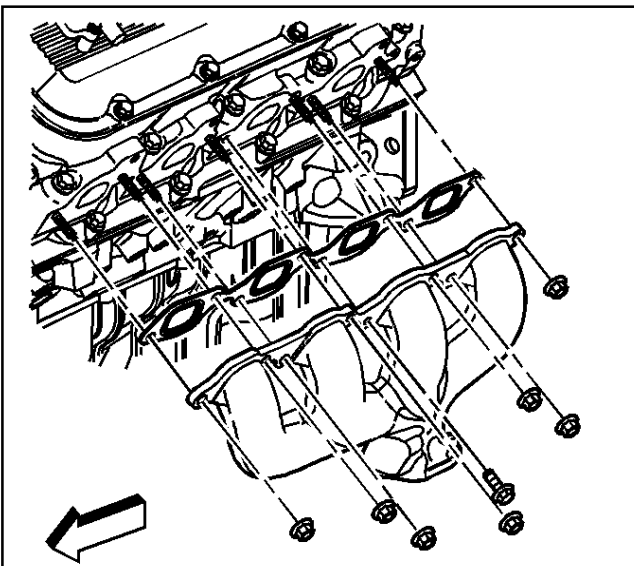

470686

4. Remove the left exhaust manifold nuts and center bolt.
5. Remove the left exhaust manifold.
6. Remove the left exhaust manifold gasket.



- 7. Remove the left spark plugs.

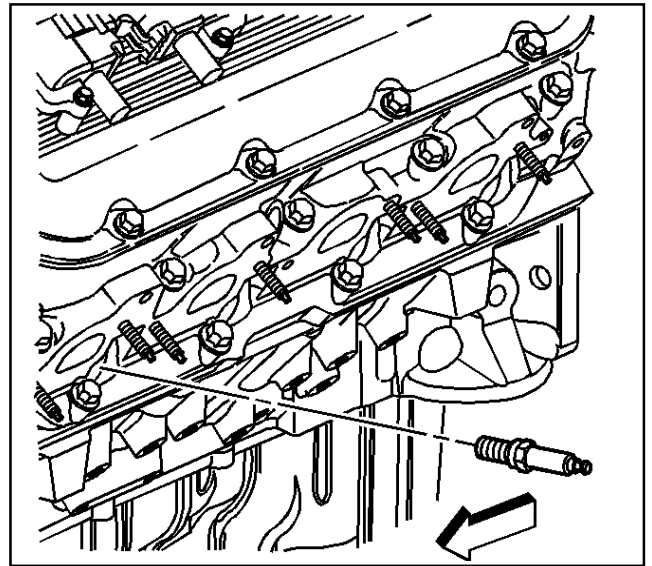

470690

- 8. Remove the exhaust manifold studs, if necessary.

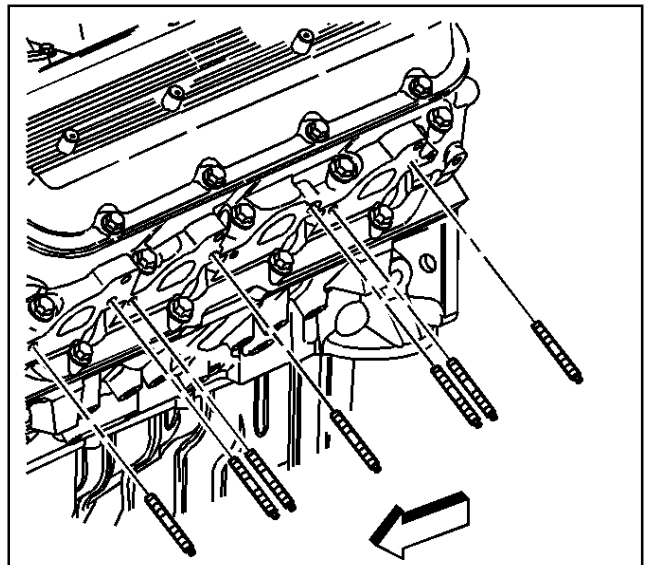

470683

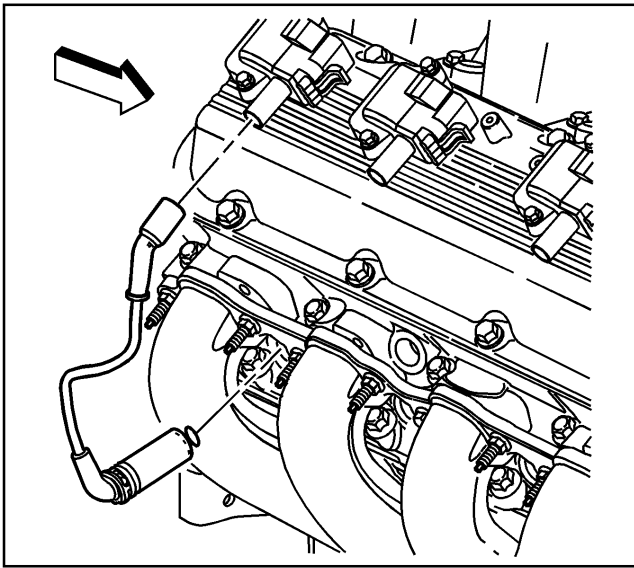

470704

### Exhaust Manifold Removal - Right

**Important:** Twist the spark plug boot one-half turn in order to release the boot. Pull on the spark plug boot only. Do not pull on the spark plug wire or the wire could be damaged.

1. Remove the left spark plug wires from the spark plugs and ignition coils.

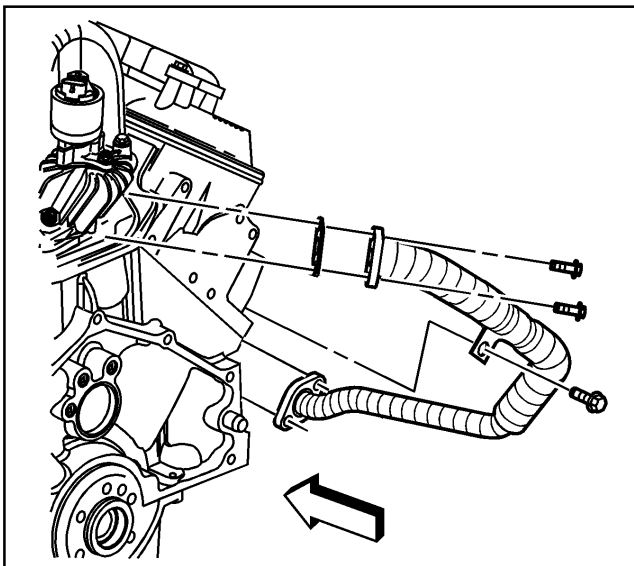

470737

2. Remove the Exhaust Gas Recirculation (EGR) pipe bolts from the EGR adapter plate.
3. Remove the EGR pipe nuts from the right exhaust manifold.
4. Remove the EGR pipe bracket bolt.
5. Remove the EGR pipe and gaskets.

6. Remove the right exhaust manifold heat shield bolts and nuts.
7. Remove the right exhaust manifold heat shield.

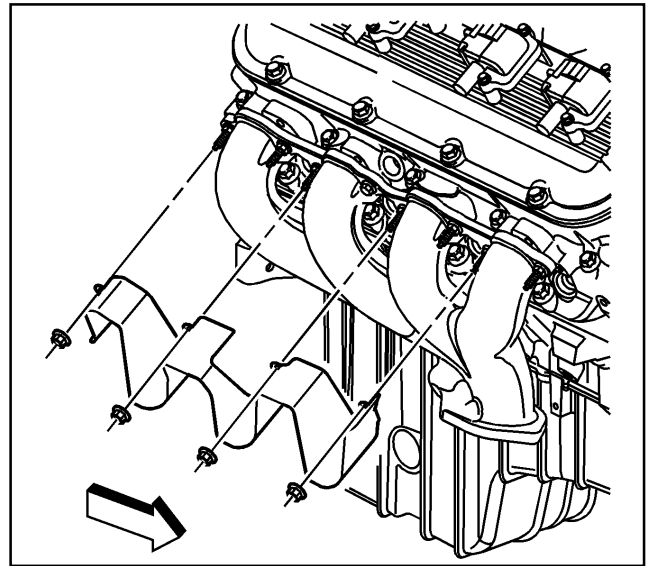

470708

8. Remove the right exhaust manifold nuts and center bolt.
9. Remove the right exhaust manifold.
10. Remove the right exhaust manifold gasket.

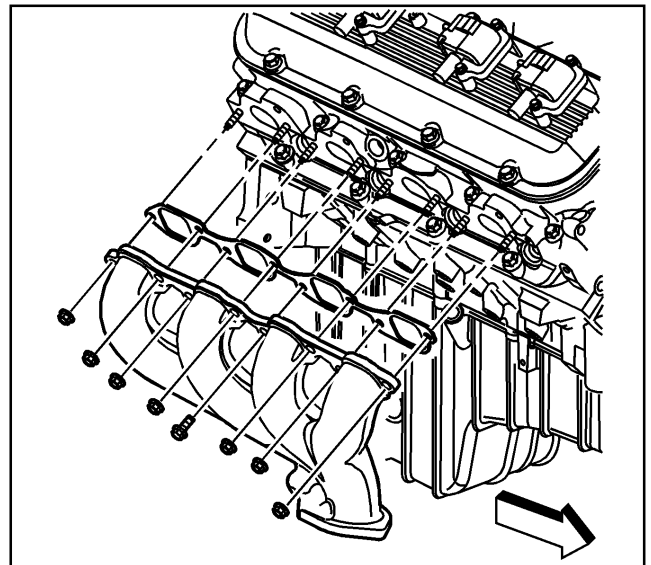

470725

11. Remove the right spark plugs.

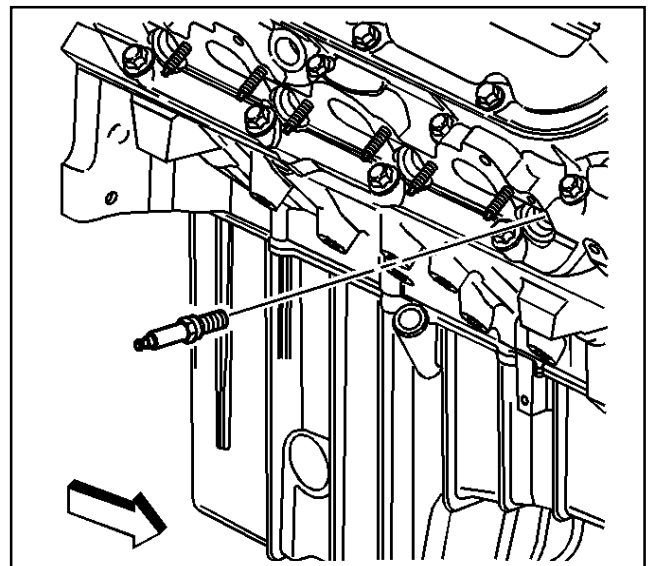

470727

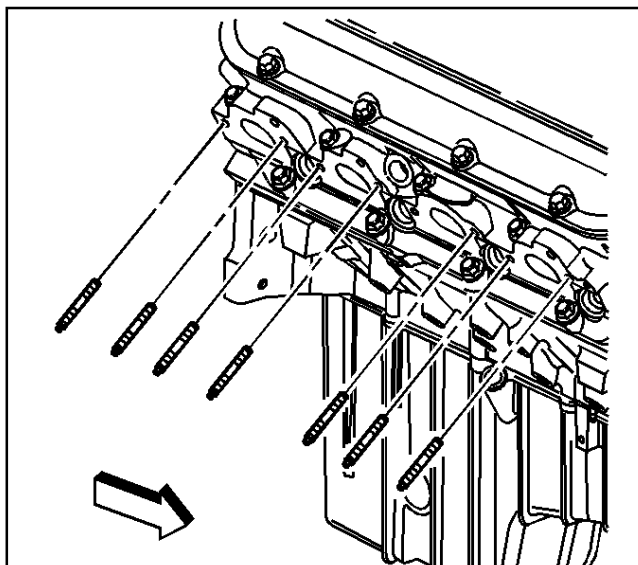

470723

12. Remove the exhaust manifold studs, if necessary.

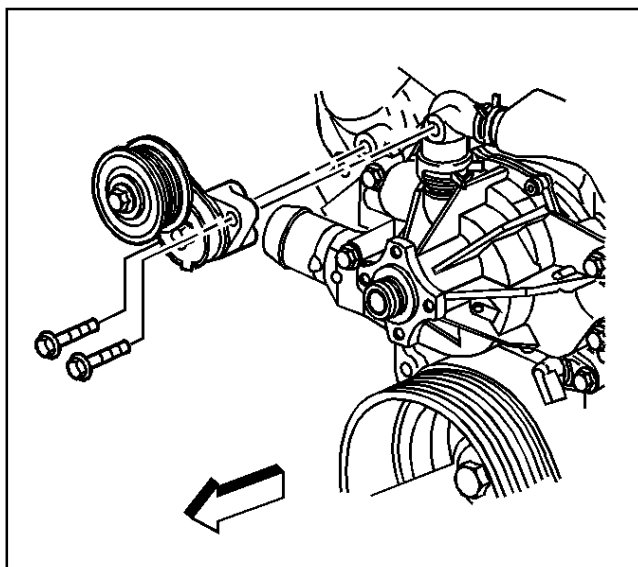

470789

### Coolant Crossover Removal

1. Remove the drive belt tensioner bolts.
2. Remove the drive belt tensioner.

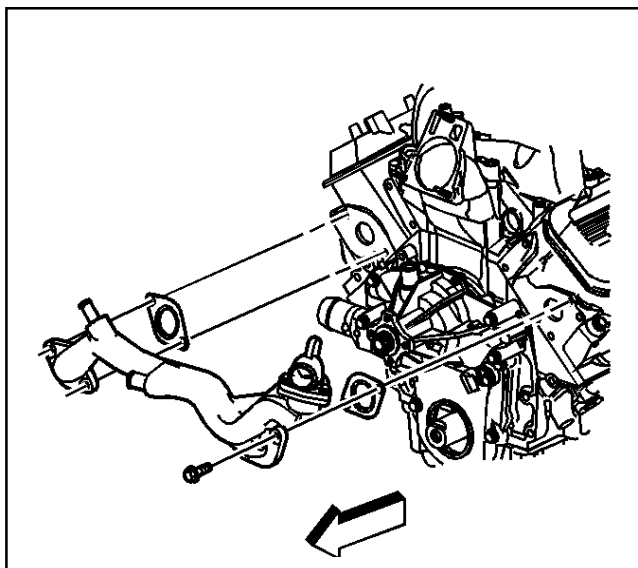

470698

3. Remove the bypass hose.

4. Remove the coolant crossover bolts.
5. Remove the coolant crossover.
6. Remove the coolant crossover gaskets.

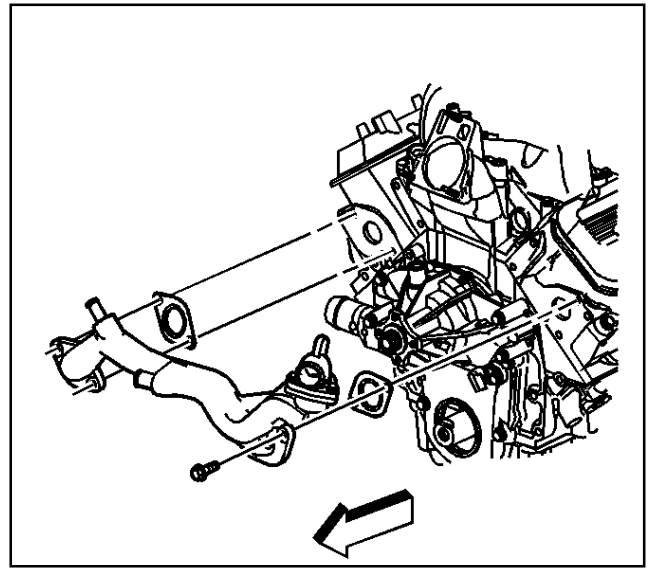

470698

7. Remove the water outlet bolts (2).
8. Remove the water outlet (1).
9. Remove the thermostat (3) from the coolant crossover.

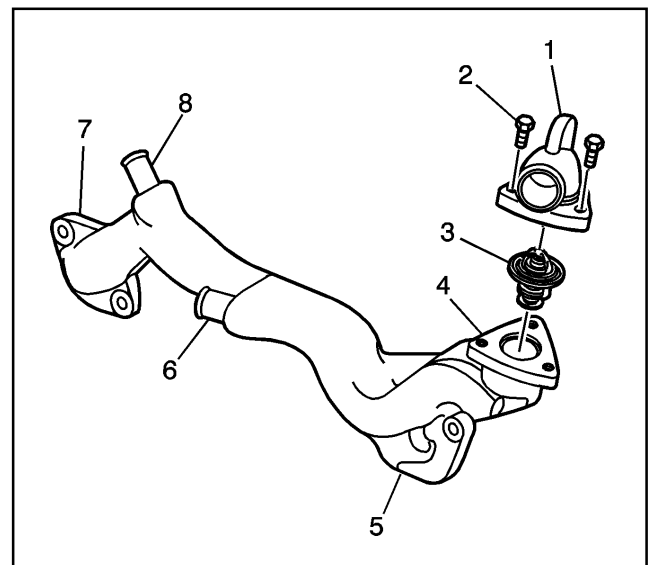

635643

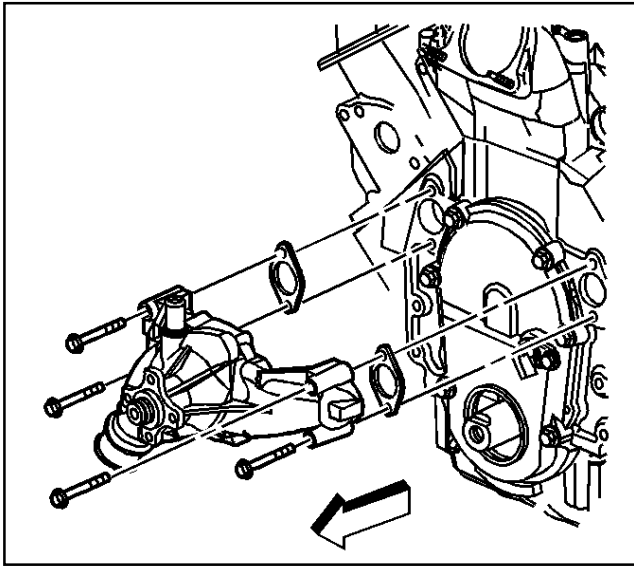

470792

### Water Pump Removal

1. Remove the water pump bolts.
2. Remove the water pump.
3. Remove the water pump gaskets.

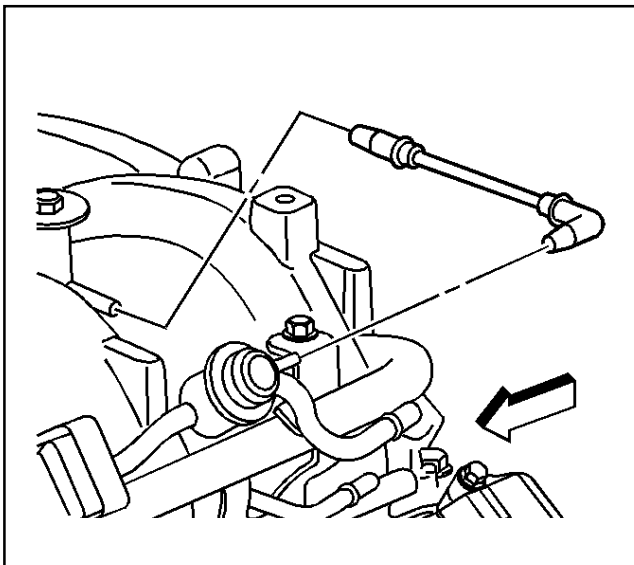

470770

### Intake Manifold Removal

1. Remove the fuel pressure regulator vacuum hose.

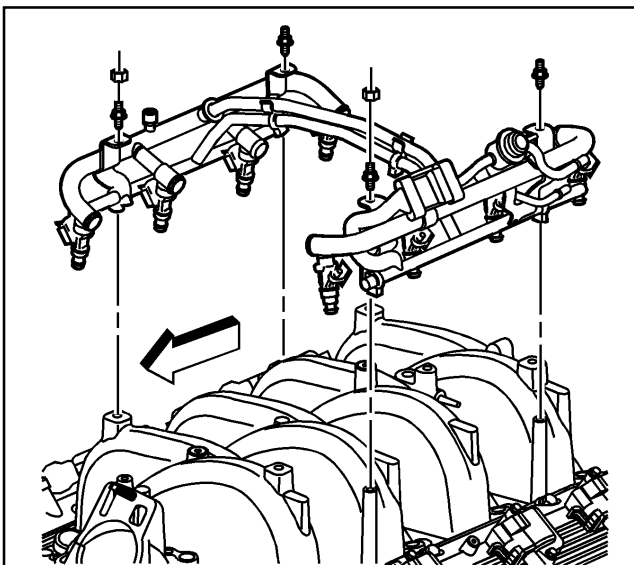

470774

2. Remove the fuel injection fuel rail bolts and/or studs.
3. Remove the fuel injection fuel rail.

4. Remove the intake manifold bolts.

**Important:** Do not attempt to loosen the manifold by prying under the gasket surface with any tool.

5. Remove the intake manifold.

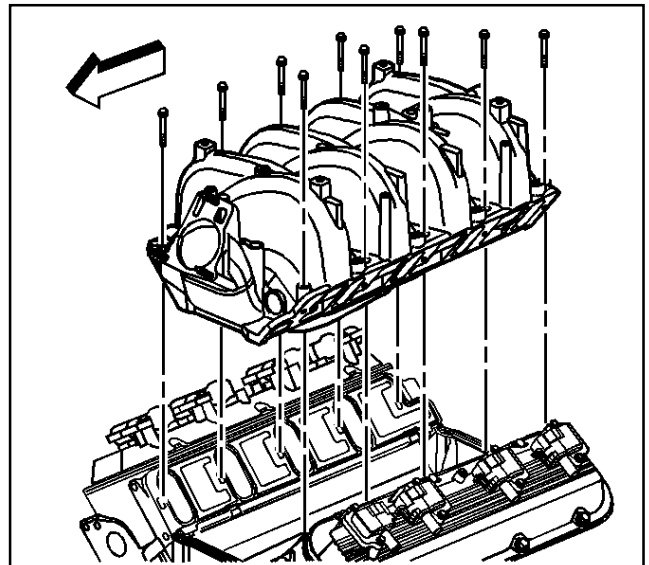

470775

**Important:** The intake manifold gaskets are not reusable.

6. Remove and discard the intake manifold side gaskets.

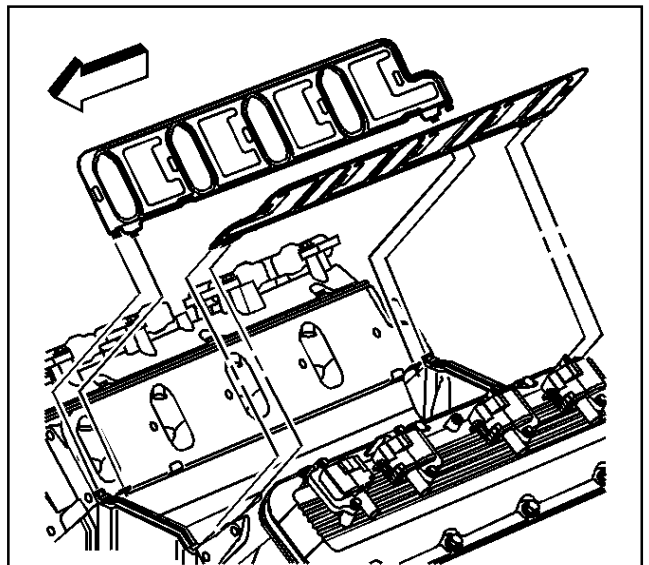

470779

7. Remove and discard the lower intake manifold end seals.

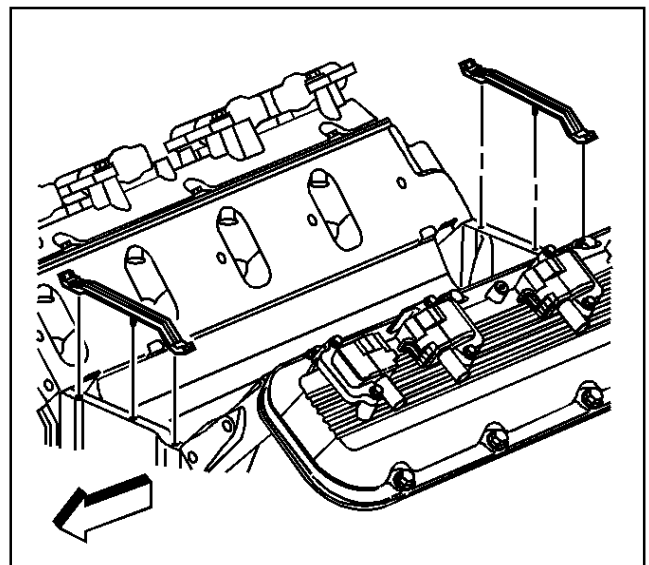

470783

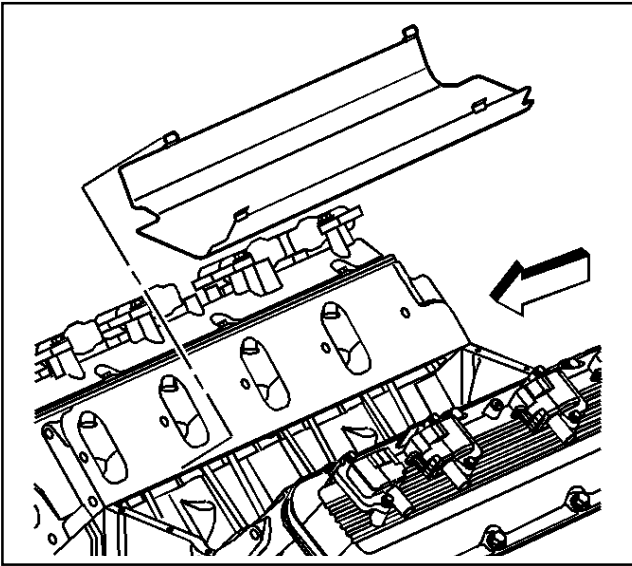

470786

**Important:** The splash shield is secured using a snap-fit. Do not distort the splash shield. The splash shield is reusable.

8. Remove the splash shield.

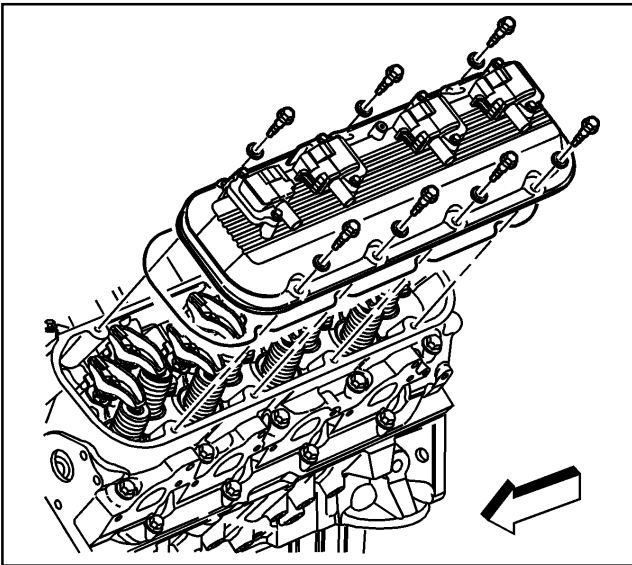

470890

### Valve Rocker Arm Cover Removal - Left

1. Remove the valve rocker arm cover bolts.
2. Remove the valve rocker arm cover.

**Important:** The valve rocker arm cover gasket may be reused if not removed from the valve rocker arm cover.

3. Replace the valve rocker arm cover gasket if it is cut or damaged.

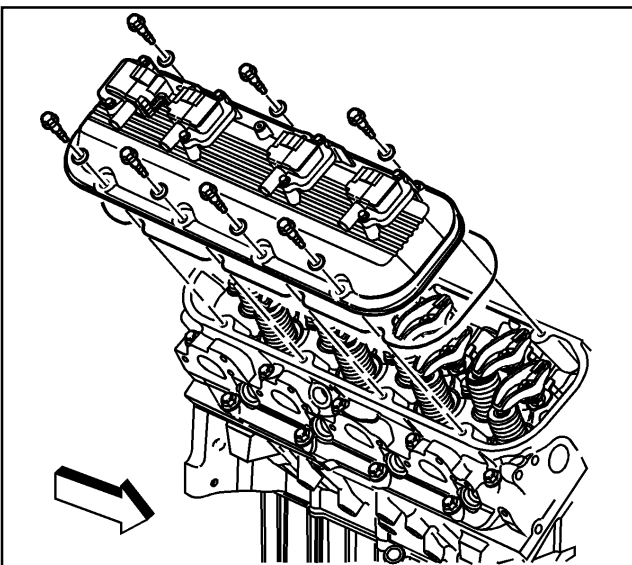

470897

### Valve Rocker Arm Cover Removal - Right

1. Remove the valve rocker arm cover bolts.
2. Remove the valve rocker arm cover.

**Important:** The valve rocker arm cover gasket may be reused if not removed from the valve rocker arm cover.

3. Replace the valve rocker arm cover gasket if it is cut or damaged.



**Valve Rocker Arm and Push Rod Removal**

**Important:** Mark, organize and sort the cylinder head components. Return the components to their original location during reassembly. Make an organizer rack from a piece of wood.

1. Remove the valve rocker arm nuts, the valve rocker arm balls and the valve rocker arms.

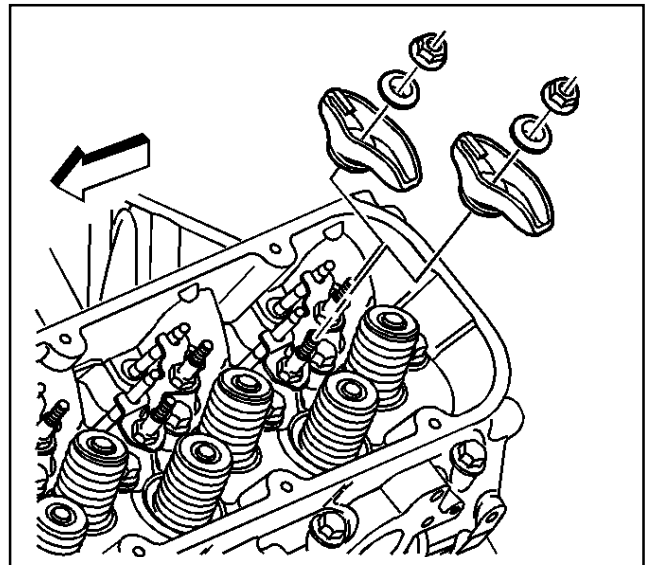

470899

**Important:** The exhaust valve push rods (2) are longer than the intake valve push rods (1).

2. Remove the valve push rods.

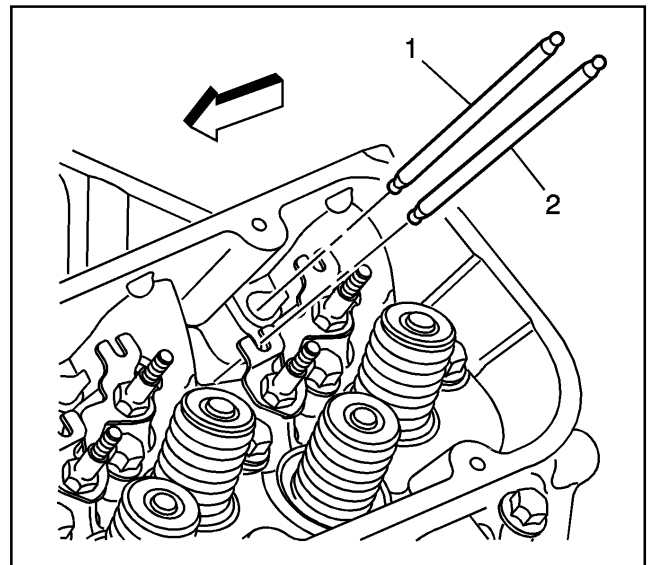

470903

3. Remove the valve rocker arm studs and push rod guides.

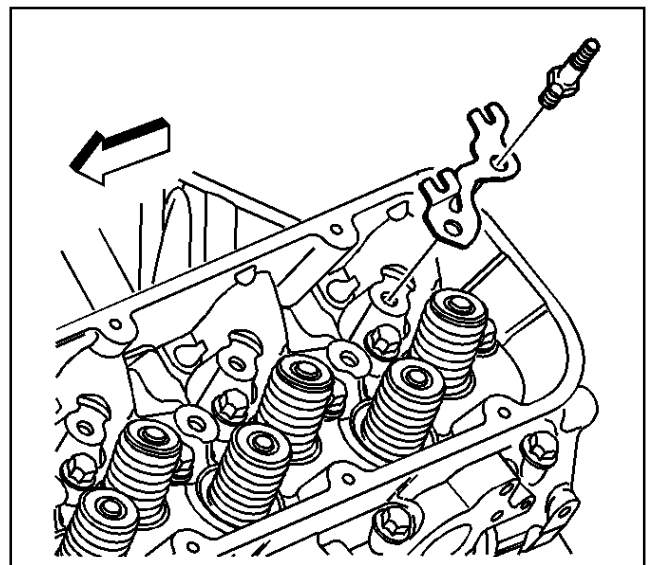

470906

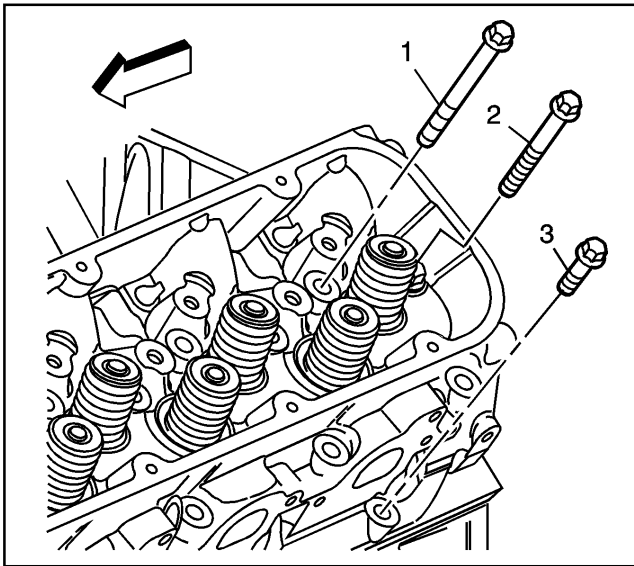

470914

### Cylinder Head Removal - Left

1. Remove and discard the eighteen cylinder head bolts (1,2,3).

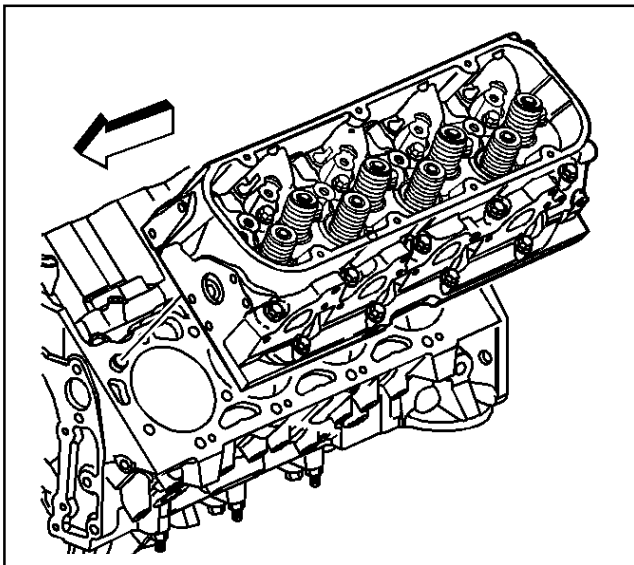

470916

**Important:** Place cylinder head on two wood blocks to prevent damage to the sealing surfaces.

2. Remove the cylinder head.

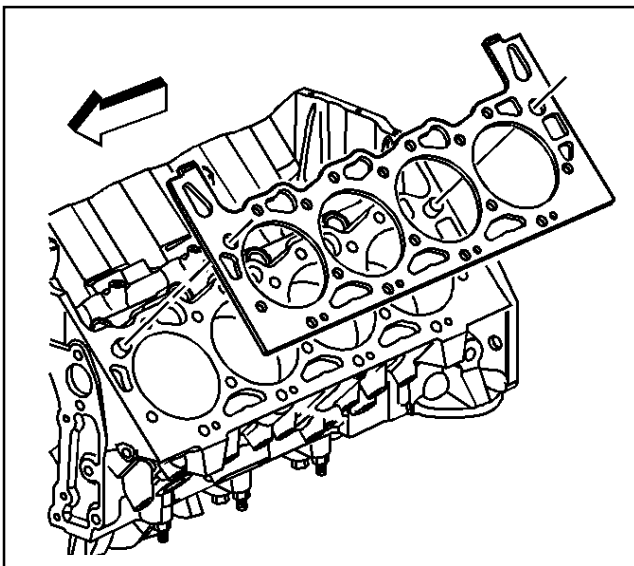

470974

3. Remove the cylinder head gasket.
4. Discard the cylinder head gasket.

**Cylinder Head Removal - Right**

1. Remove and discard the eighteen cylinder head bolts (1,2,3).

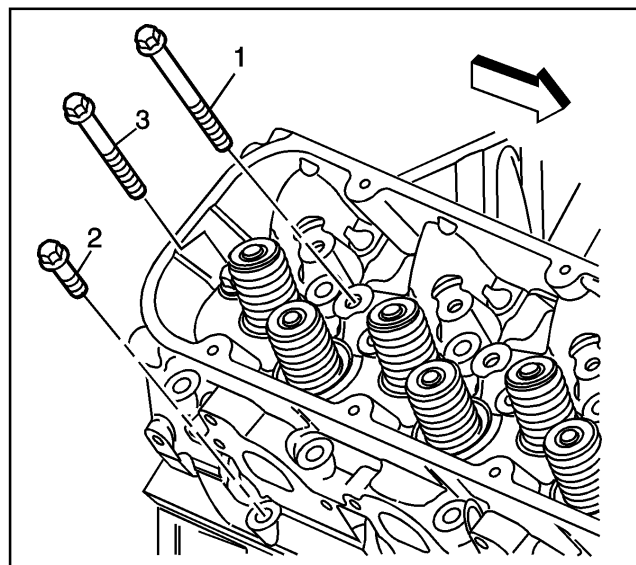

470989

**Important:** Place cylinder head on two wood blocks to prevent damage to the sealing surfaces.

2. Remove the cylinder head.

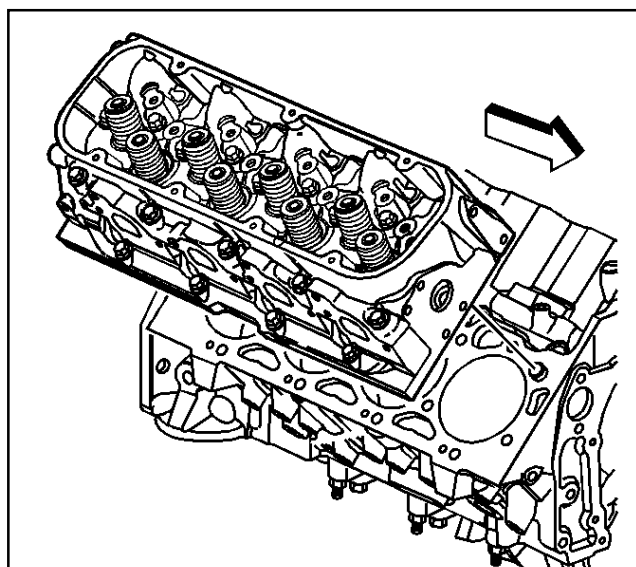

470991

3. Remove the cylinder head gasket.
4. Discard the cylinder head gasket.

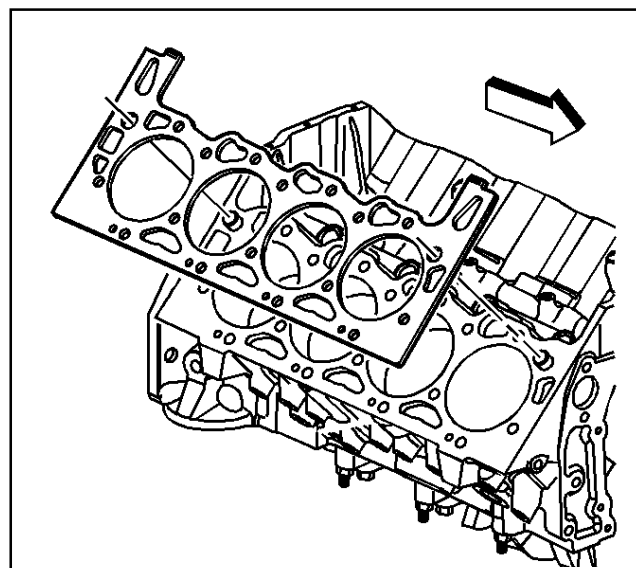

470992

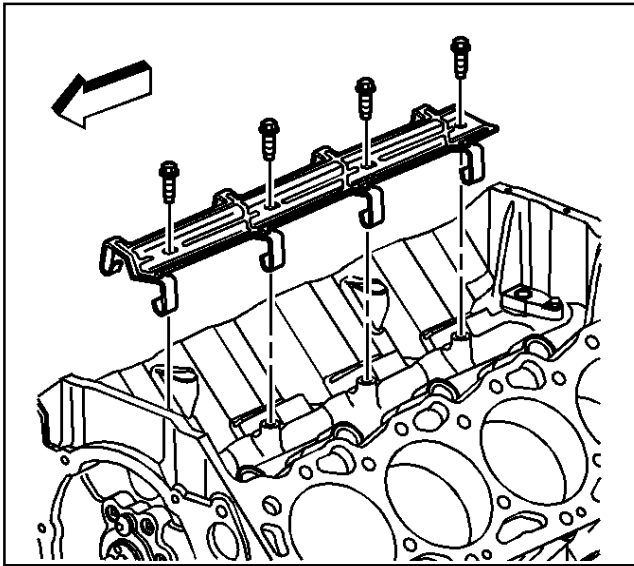

470994

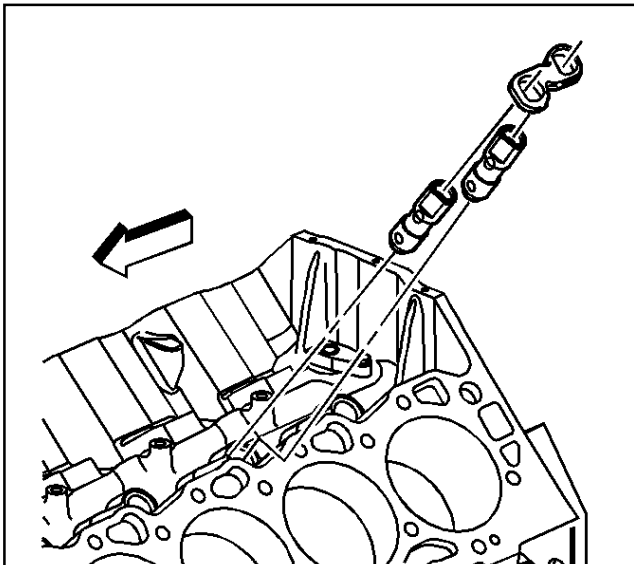

470996

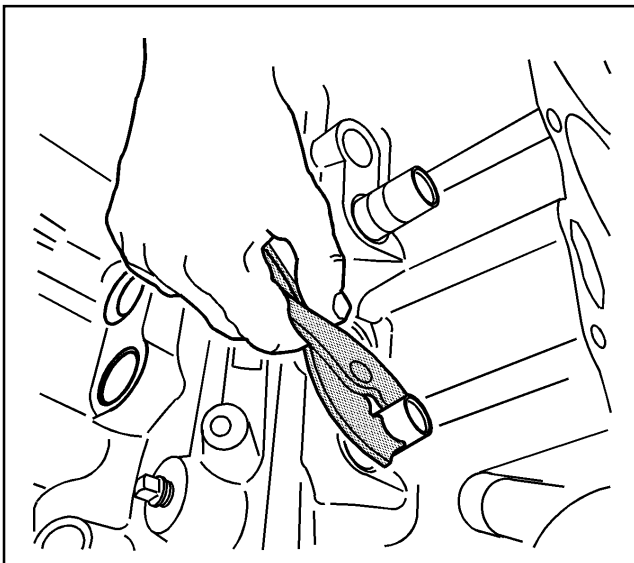

719128

## Valve Lifter Removal

### Tools Required

*J 3049-A Valve Lifter Remover*

**Important:** Mark, organize and sort the cylinder head components for return to their original location during assembly.

1. Remove the valve lifter guide retainer bolts and retainer.

2. Remove the valve lifter guides.

**Important:** Place the valve lifters in the organizer rack or tag them in a way to ensure they can be returned to the valve lifter bore from which they were removed.

3. Remove the valve lifters.

4. Some valve lifters may be stuck in their bore due to gum or varnish deposits. These lifters can be removed using the J 3049-A.

### Oil Pump Drive Removal

1. Remove the oil pump drive bolt.
2. Remove the oil pump drive.

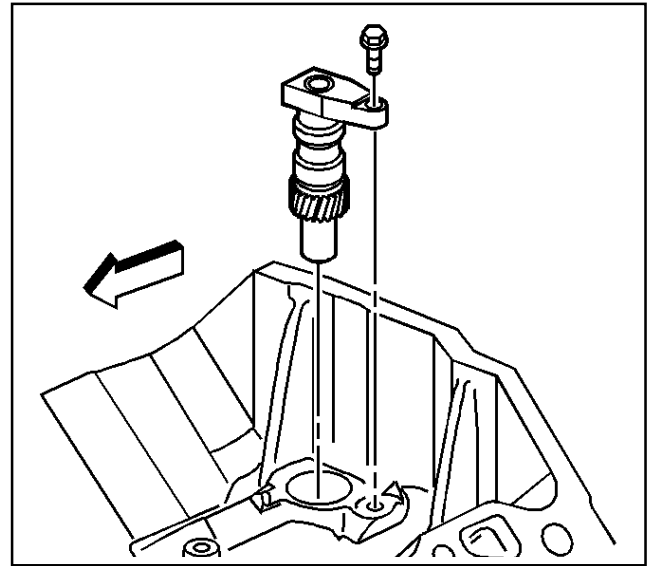

470910

### Oil Pan Removal

1. Remove the oil pan bolts.

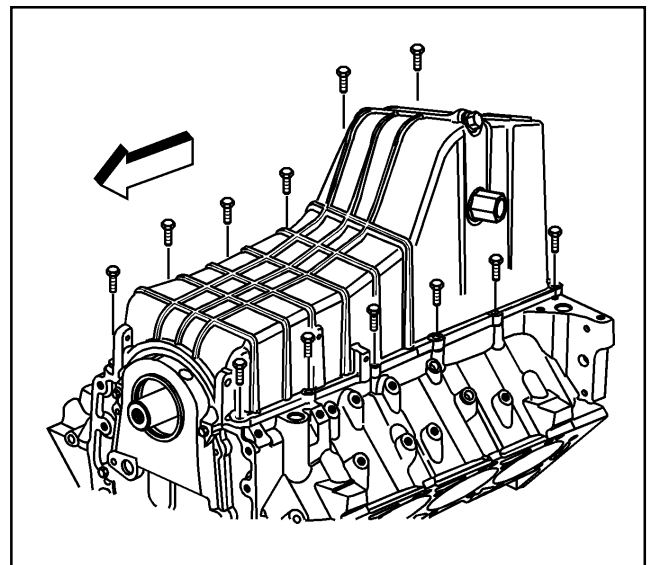

635651

**Important:** The oil pan gasket is reusable if not cut or damaged.

2. Remove the oil pan (1) and the captured oil pan gasket (2).

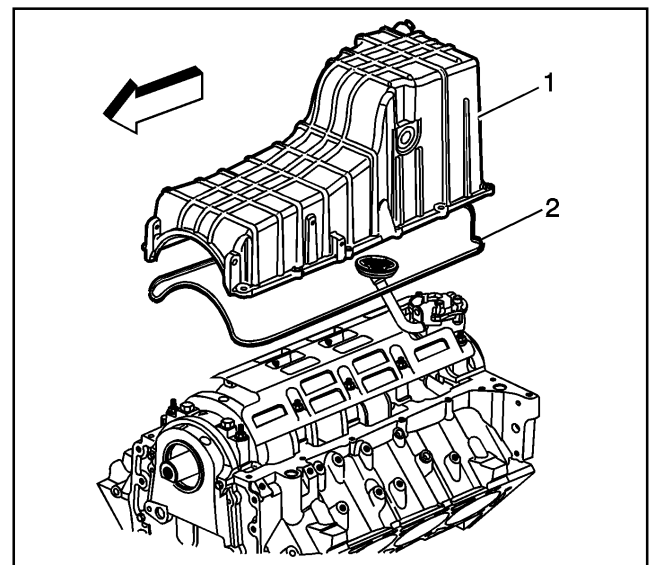

635654

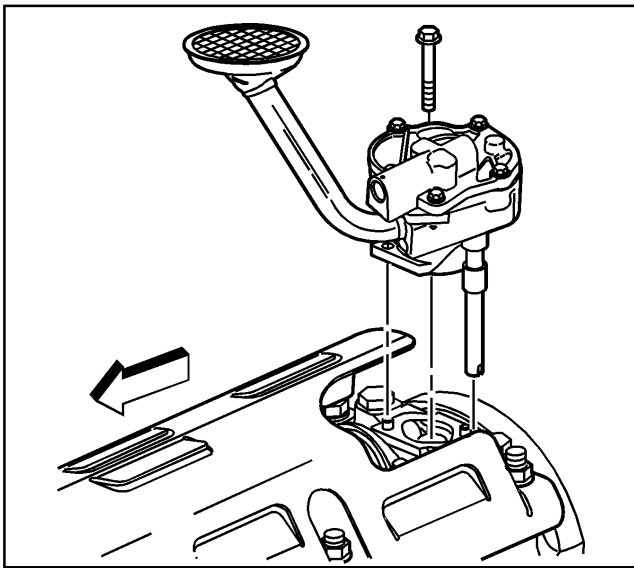

635701

### Oil Pump, Pump Screen and Deflector Removal

1. Remove the bolt that attaches the oil pump to the rear crankshaft bearing cap.
2. Remove the oil pump, driveshaft and retainer from the rear crankshaft bearing cap.
3. Separate the oil pump, driveshaft and retainer.
4. Discard the driveshaft retainer.

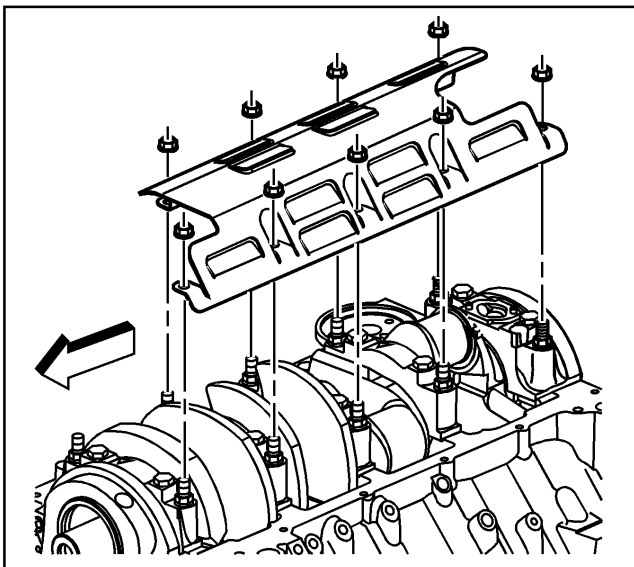

635703

5. Remove the crankshaft oil deflector nuts.
6. Remove the crankshaft oil deflector.

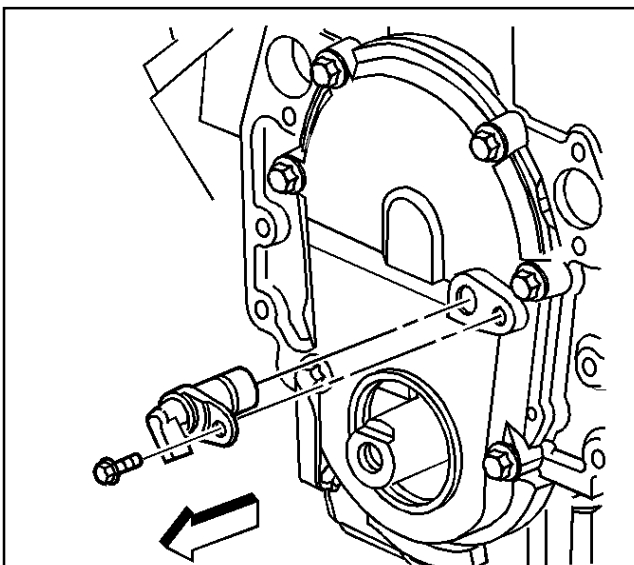

470803

### Engine Front Cover Removal

**Important:** Care should be taken when removing the self-tapping bolt. Failure to use caution may cause bolt and/or component failure.

1. Remove the camshaft position sensor bolt.
2. Remove the camshaft position sensor.
3. Inspect the camshaft position sensor O-ring for cuts, cracks, tears or damage. Replace the O-ring as needed.

4. Remove the engine front cover bolts.
5. Remove the engine front cover.

**Important:** The engine front cover gasket is reusable.

6. Remove the engine front cover gasket.
7. Remove the crankshaft front oil seal from the engine front cover.

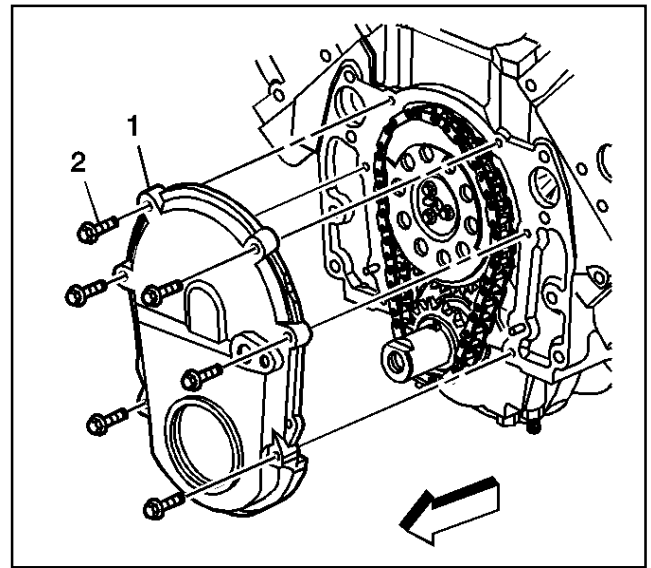

470805

### Timing Chain and Sprockets Removal

#### Tools Required

*J 42846* Crankshaft Protector Button

1. Measure the camshaft timing chain free play. If the chain can be moved back and forth in excess of 16 mm (0.625 in), make a note that the camshaft timing chain and the sprockets must be replaced during assembly.
2. Remove the camshaft sprocket bolts.
3. Remove the camshaft sprocket and the camshaft timing chain.

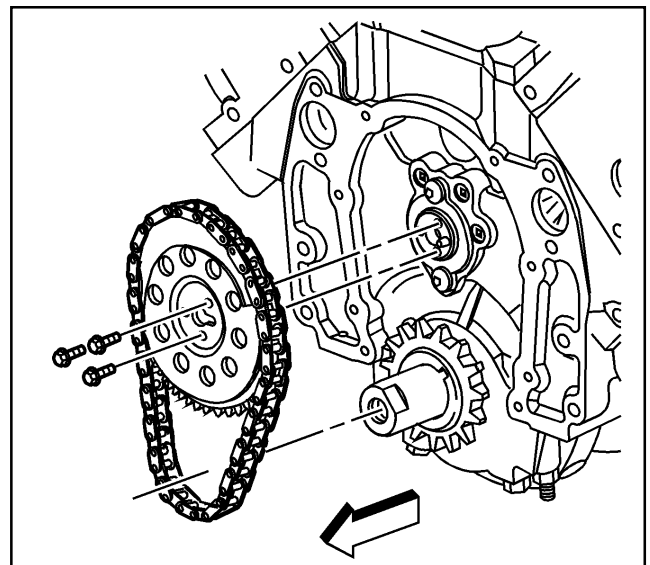

470814

4. Install the *J 42846* into the end of the crankshaft.
5. Remove the crankshaft sprocket using a suitable three jaw puller.

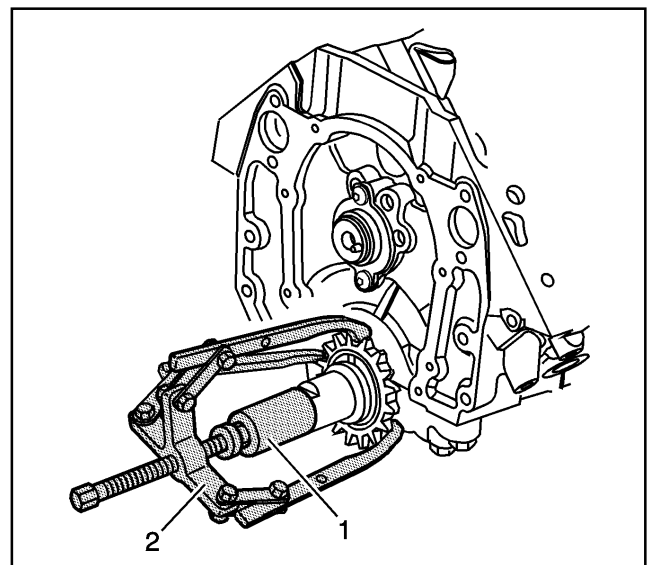

639535

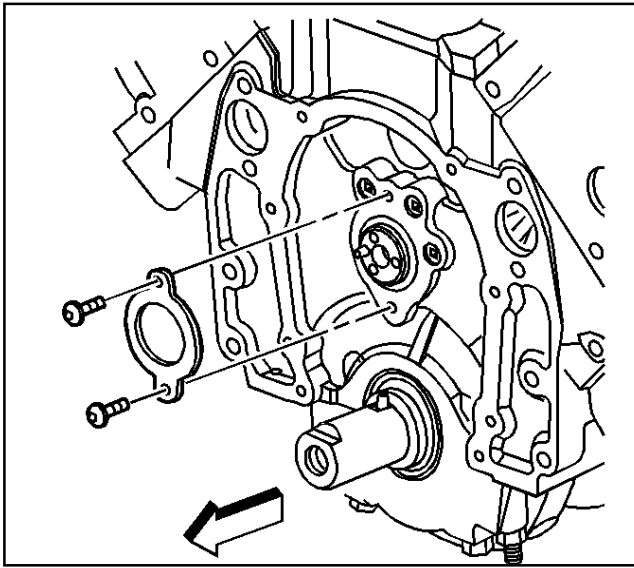

470998

### Camshaft Removal

1. Remove the camshaft retainer bolts.
2. Remove the camshaft retainer.

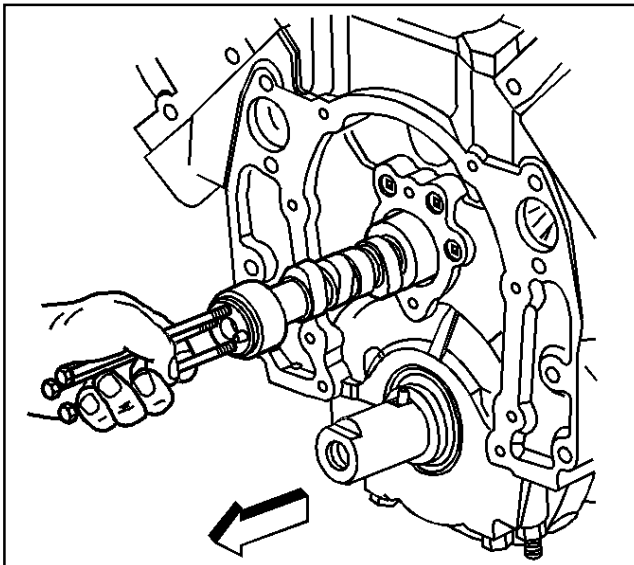

471002

3. Install three 8-1.25 x 100 mm bolts in the camshaft front bolt holes.

**Notice:** All camshaft journals are the same diameter, so care must be used in removing or installing the camshaft to avoid damage to the camshaft bearings.

4. Using the bolts as a handle, carefully rotate and pull the camshaft out of the engine block.
5. Remove the bolts from the front of the camshaft.



**Piston, Connecting Rod and Bearing Removal**

**Tools Required**

J 24270 Ridge Reamer

J 42846 Crankshaft Protector Button

**Important:** Do not remove the excessive material from the cylinder bore. Excessive removal of material may require cylinder boring to next oversize.

1. Remove the cylinder bore ridge as necessary.
  - 1.1. Install the J 42846 onto the front of the crankshaft in order to turn the crankshaft.
  - 1.2. Rotate the crankshaft until the piston is at the bottom of the stroke (BDC).
  - 1.3. Place a cloth on top of the piston.
  - 1.4. Perform the cutting operation with a J 24270. Refer to the manufacturer's instructions before using the J 24270.
  - 1.5. Remove the J 24270.
  - 1.6. Rotate the crankshaft until the piston is at top dead center (TDC).
  - 1.7. Remove the cloth and the cuttings.
  - 1.8. Repeat this procedure for each piston.

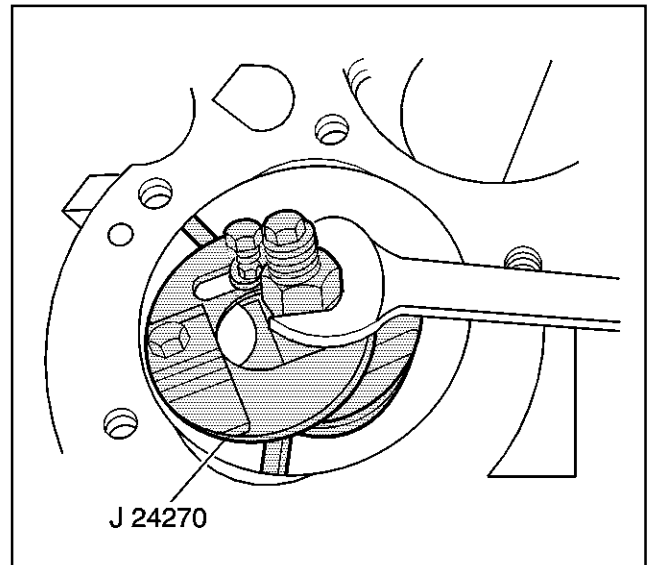

11497

**Important:** Place the matching marks or numbers on the connecting rods and the connecting rod caps. The connecting rod caps must be reassembled to their connecting rods.

**Important:** When connecting rod bearings are removed, NEW bearings must be installed.

2. Remove the connecting rod nuts.
3. Remove the connecting rod cap and lower connecting rod bearing.

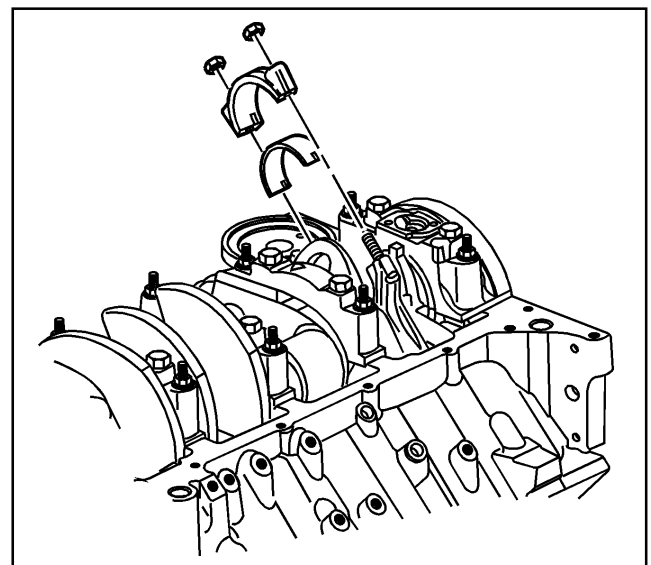

639084

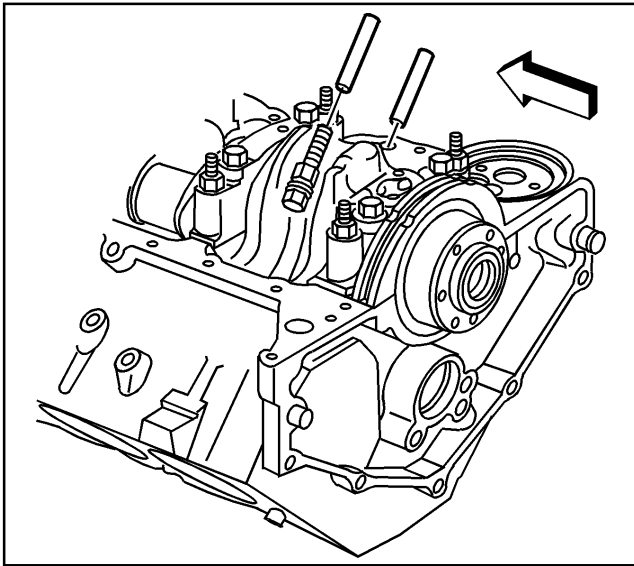

639533

4. Install rubber fuel line onto the connecting rod bolts.

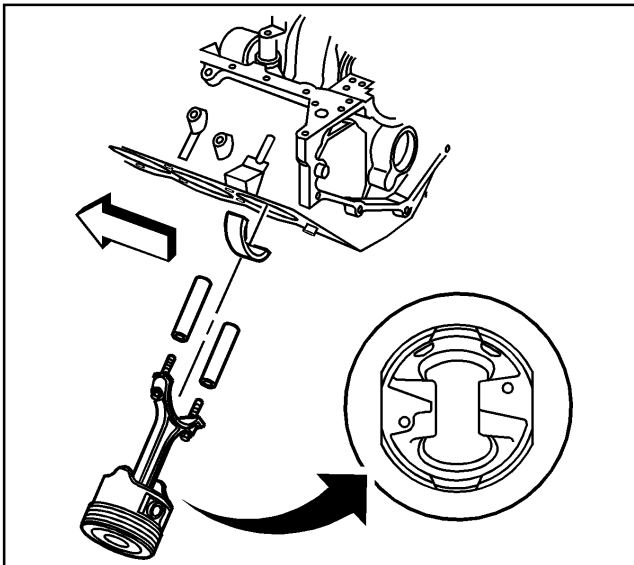

639536

5. Remove the piston, connecting rod and upper connecting rod bearing out of the top of the engine block.

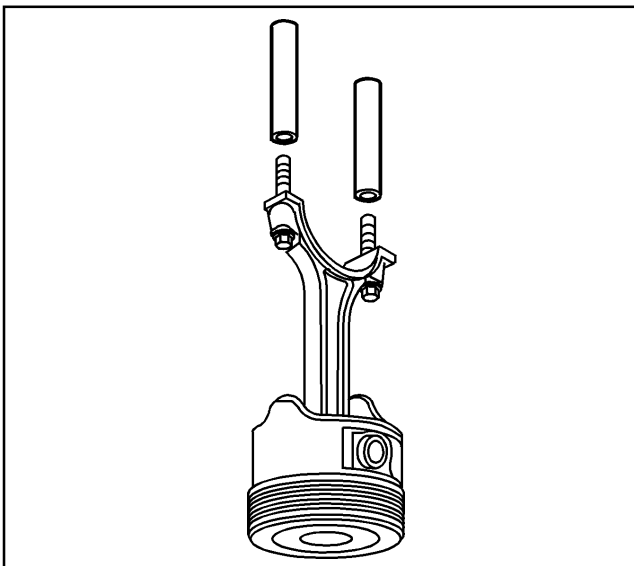

639532

6. Remove the rubber fuel line from the connecting rod bolts.
7. Remove the remaining piston and the connecting rod.
8. Remove the J 42846 from the front of the crankshaft.

**Crankshaft Rear Oil Seal Removal**

**Tools Required**

J 43320 Crankshaft Rear Seal Puller

1. Install the J 43320 guide pins into the crankshaft.

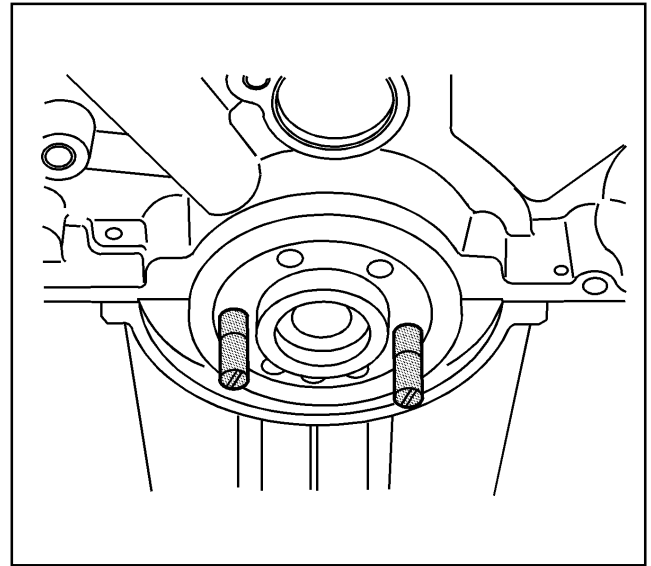

655276

2. Install the J 43320 over the guide pins.
3. Using a suitable drill, insert eight of the self-drilling sheet metal screws into the rear crankshaft seal, using a criss-cross pattern. The self-drilling screws are included with the J 43320.

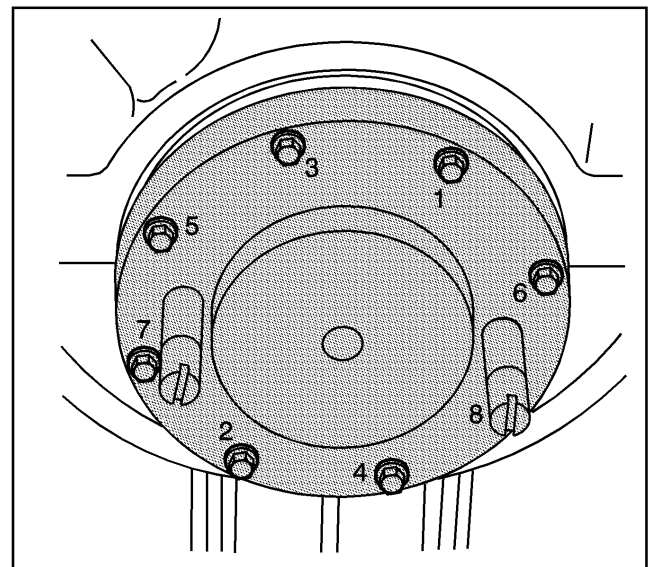

655278

4. Thread the center bolt of J 43320 into the crankshaft to remove the seal.
5. Remove the J 43320 guide pins from the crankshaft.

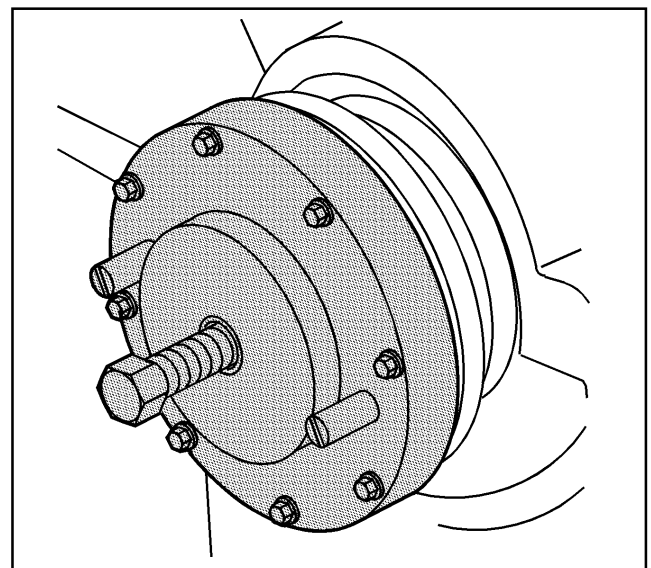

655279

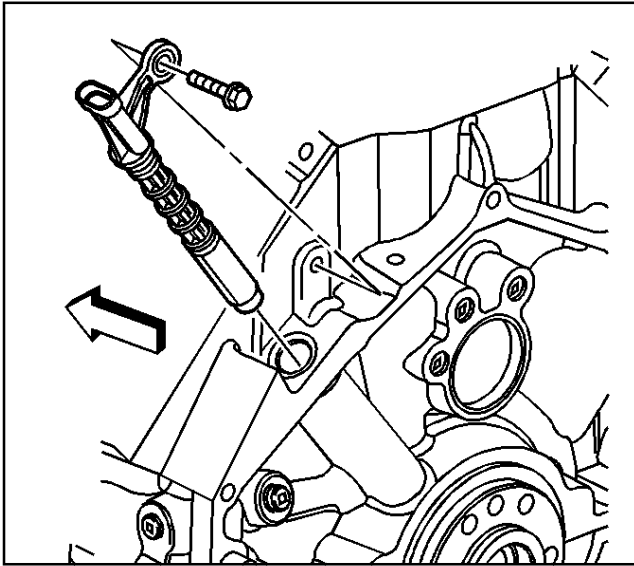

470801

### Crankshaft and Bearings Removal

**Important:** The crankshaft position sensor is designed to contact the reluctor wheel of the crankshaft. Wear may be noticeable on the end of the sensor.

1. Remove the crankshaft position sensor bolt.
2. Apply penetrating oil to the crankshaft position sensor-to-engine block mating surface. Allow the penetrating oil to soak for several minutes, to help loosen the O-ring from the engine block.
3. Remove the crankshaft position sensor.
4. Inspect both crankshaft position sensor O-rings for cuts, cracks, tears or damage. Replace the O-rings as needed.

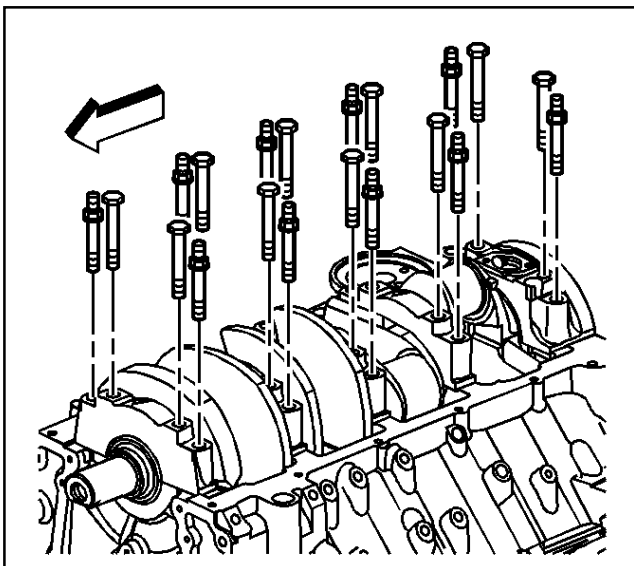

471055

**Important:** Crankshaft bearing caps are machined with the engine block for the proper clearances. Mark or identify each crankshaft bearing cap location and direction before removal. Crankshaft bearing caps must be installed in their original locations.

5. Remove the crankshaft bearing cap bolts and studs.

6. Remove the crankshaft bearing caps.
7. Remove the crankshaft lower bearings from the crankshaft bearing caps.

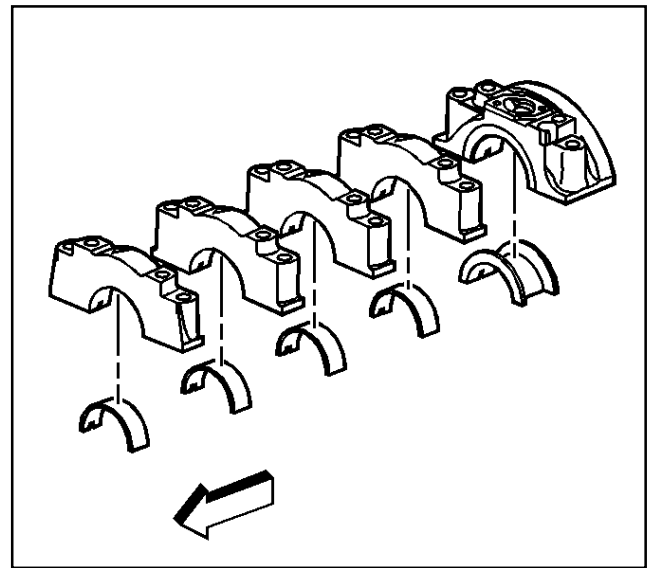

471044

**Important:** Care should be taken when removing the crankshaft so that the crankshaft position sensor reluctor ring is not damaged.

8. Remove the crankshaft.

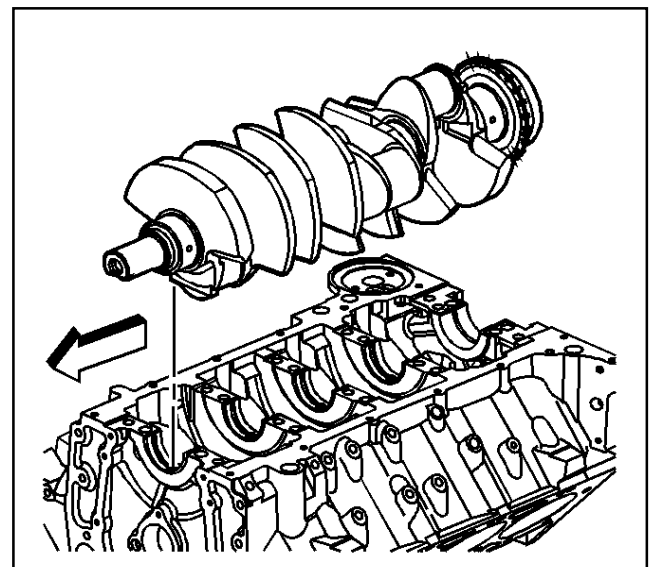

471047

**Notice:** Do not shim, scrape or file bearing inserts. Do not touch the bearing surface with bare fingers. Skin oil and acids will etch the bearing surface.

9. Remove the crankshaft upper bearings from the engine block.

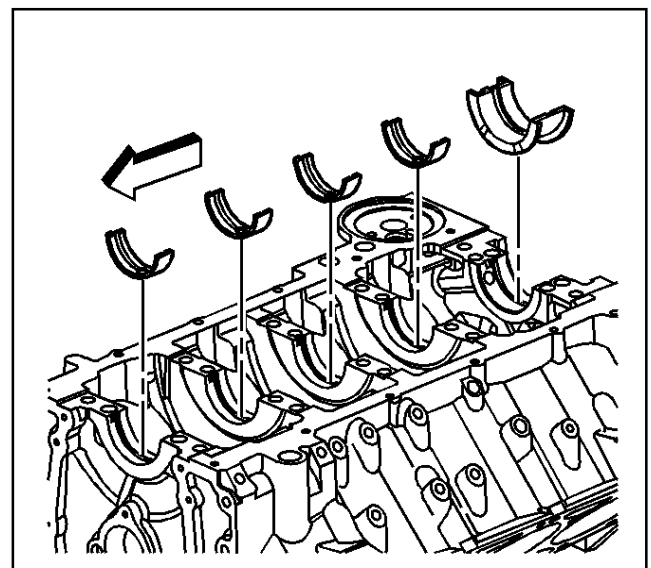

471041

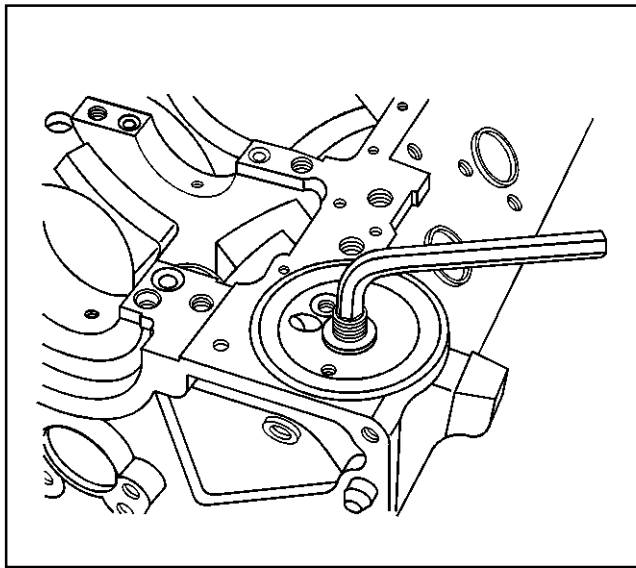

452375

### Oil Filter Adapter Removal

1. Loosen the oil filter fitting using a hex wrench.

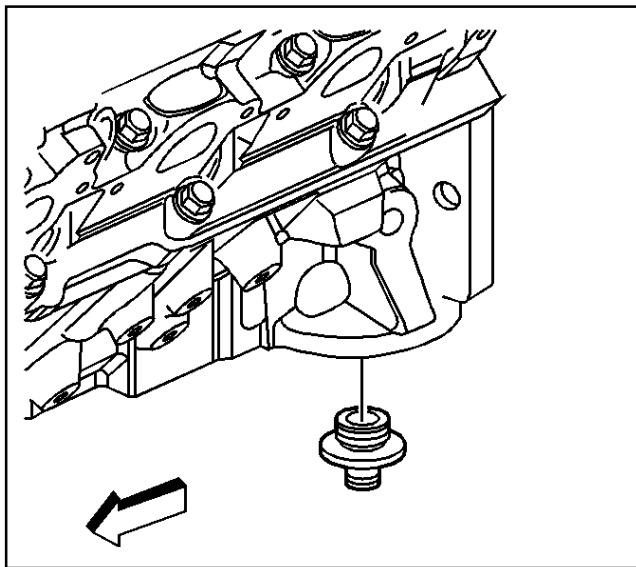

471026

2. Remove the oil filter fitting.
3. Inspect the oil filter fitting, replace if necessary.

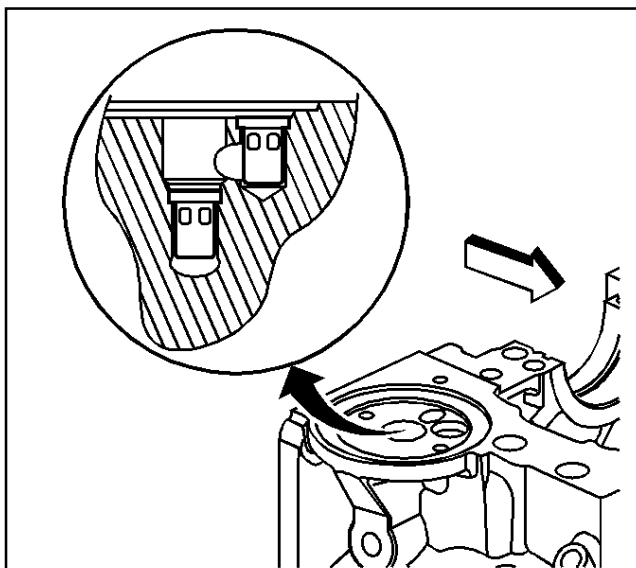

471143

4. Remove the oil bypass valves (if required).  
Unstake the tangs on the oil bypass valves and remove with long nose pliers.
5. Discard the oil bypass valves, if removed.

**Engine Block Plug Removal**

**Tools Required**

J 41712 Oil Pressure Sending Unit Socket

1. Remove the oil pressure switch using J 41712.

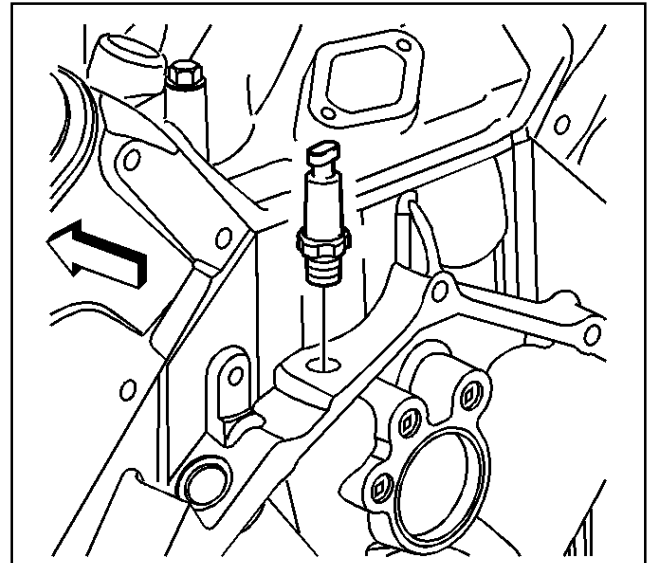

471089

2. Remove the camshaft rear bearing hole plug.
  - 2.1. Obtain a suitable self-threading screw.
  - 2.2. Drill a hole into the plug.
  - 2.3. Install the self-threading screw.
  - 2.4. Pull on the plug until it has left the bore.

**Important:** Use care not to damage the camshaft bearings.

- 2.5. An alternate method to remove the plug would be to insert a long shaft or bar through the front of the engine and drive the plug from the bore.

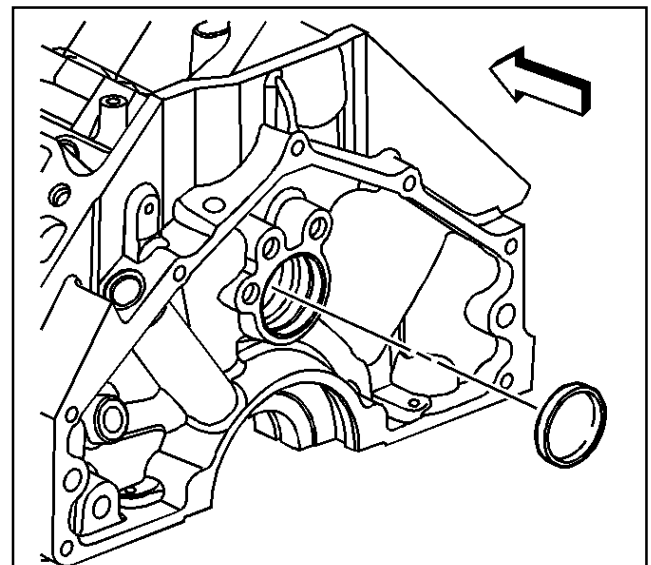

471118

3. Remove the left side knock sensor shield bolts, if applicable.
4. Remove the left side knock sensor shield, if applicable.

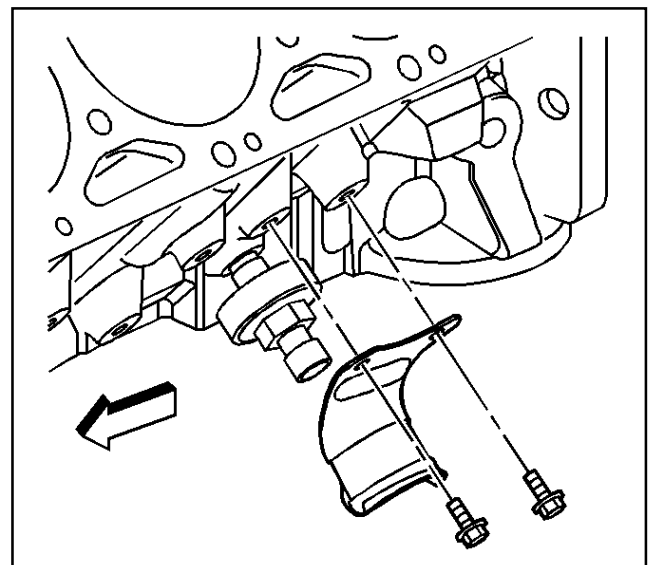

471100

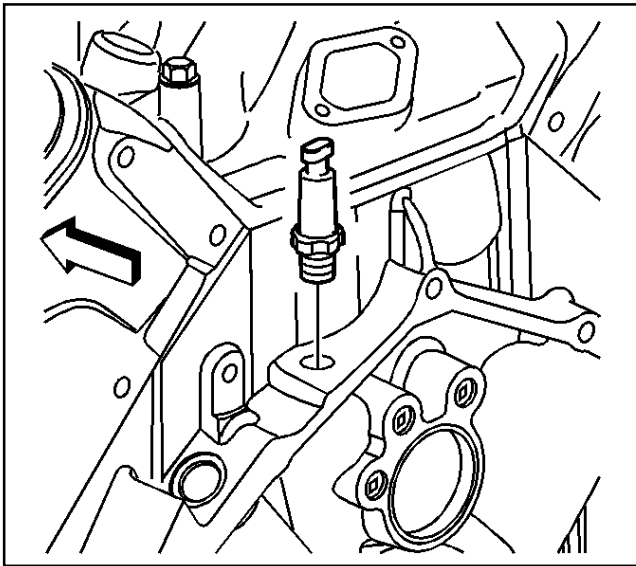

471081

5. Remove the left side knock sensor.

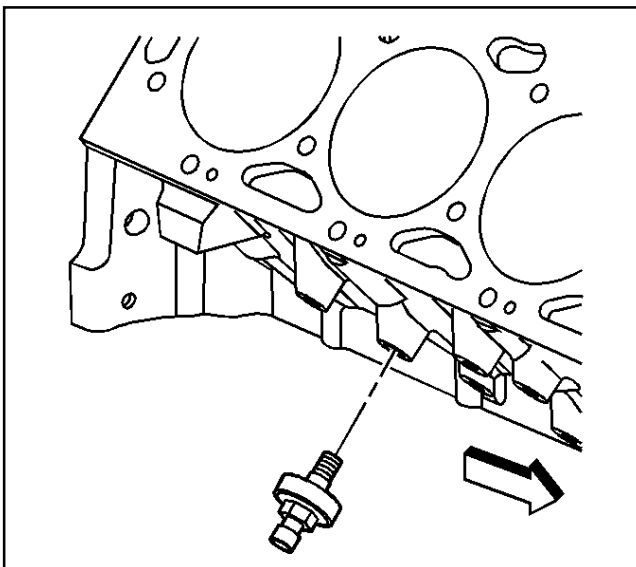

471076

6. Remove the right side knock sensor.

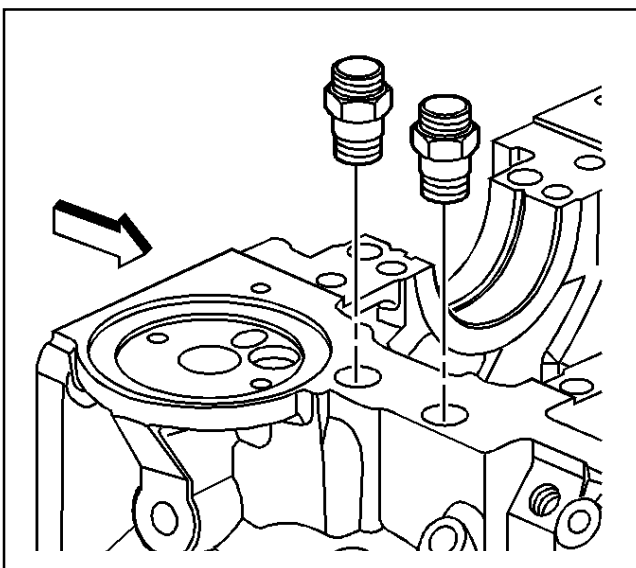

471126

7. Remove the engine block oil cooler hose fittings.



- 8. Remove the rear oil gallery plugs.

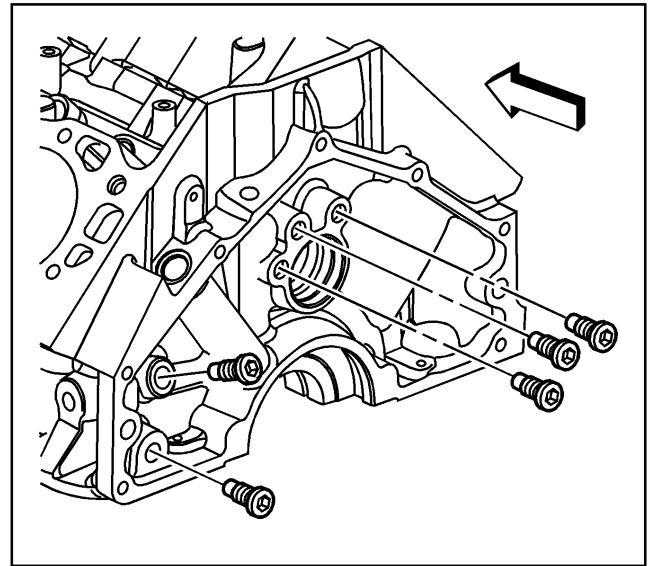

471134

- 9. Remove the front oil gallery plugs.

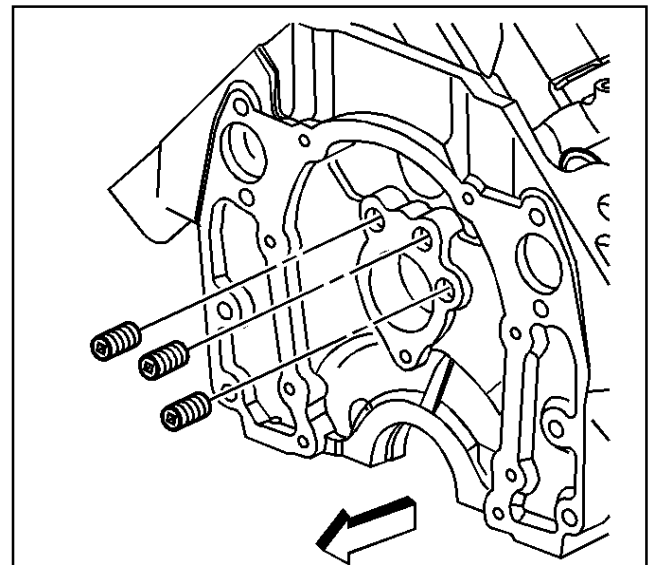

471133

- 10. Remove the left side oil gallery plugs.

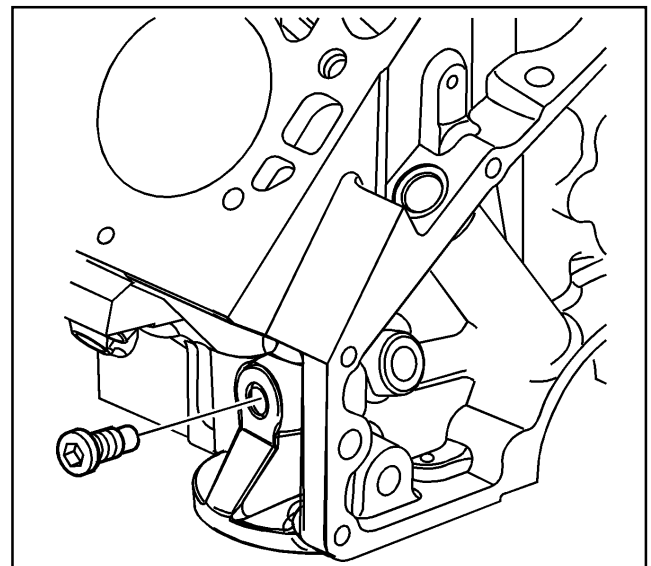

471138

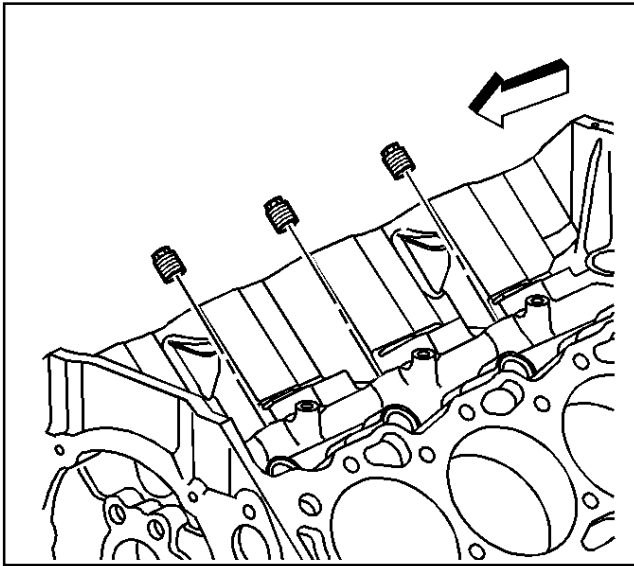

471137

11. Remove the top oil gallery plugs.

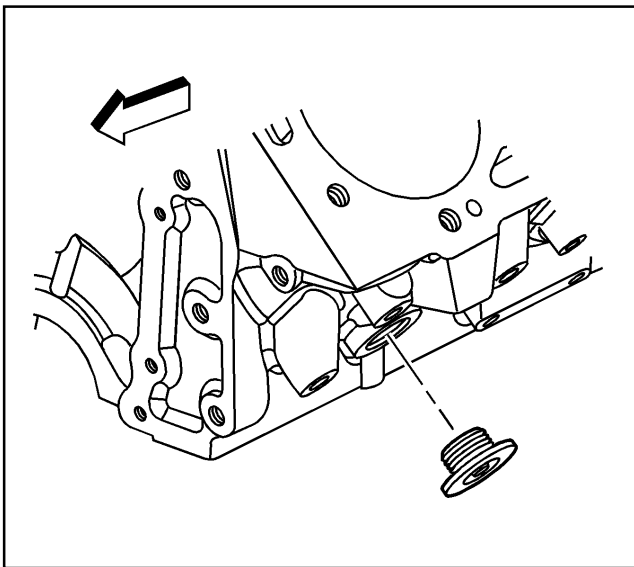

635657

12. Remove the engine coolant hole plug.

13. Remove the engine block heater, if equipped.

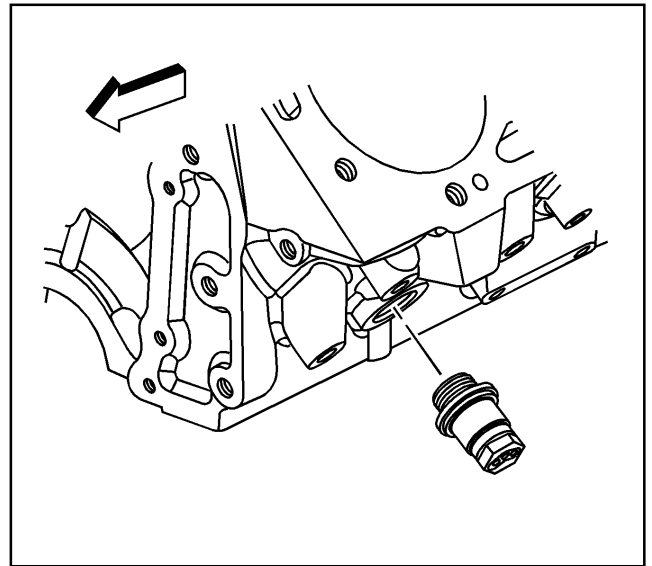

635660

### Camshaft Bearing Removal

#### Tools Required

*J 33049* Camshaft Bearing Remover/Installer

1. Remove the rear camshaft plug.  
Insert a long bar through the front of the engine and drive the plug out of the rear bore.

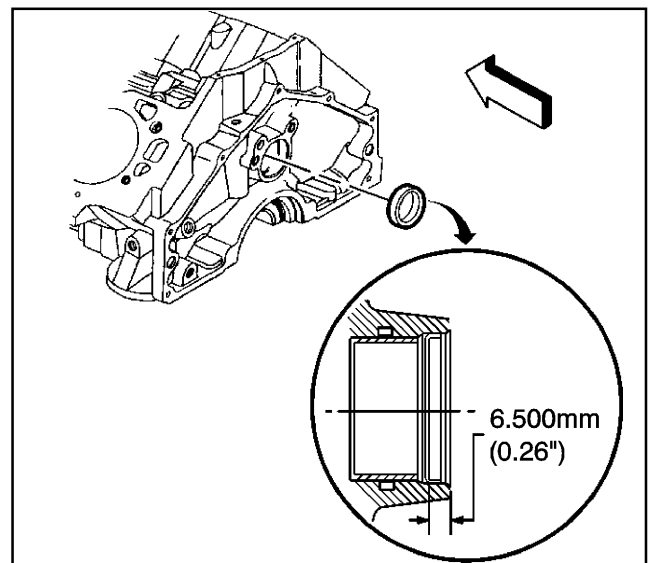

719139

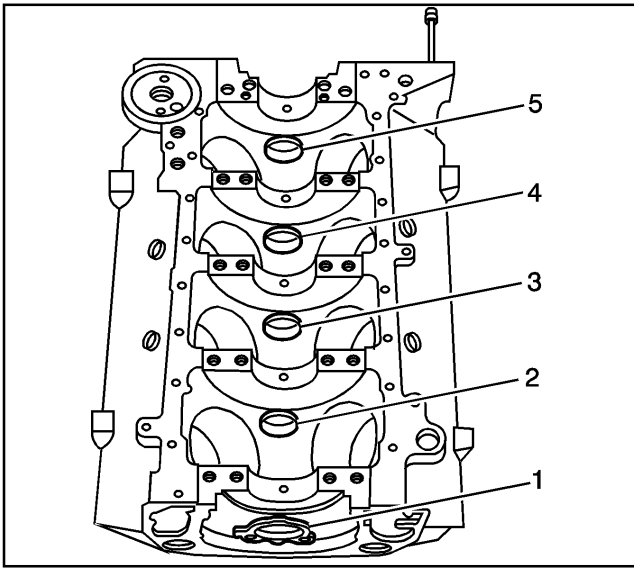

639523

**Important:** A loose camshaft bearing may be caused by an enlarged, out-of-round or damaged engine block bearing bore.

2. Prior to bearing removal, inspect the camshaft bearings for loose fit in the engine block bearing bores (positions 1-5).

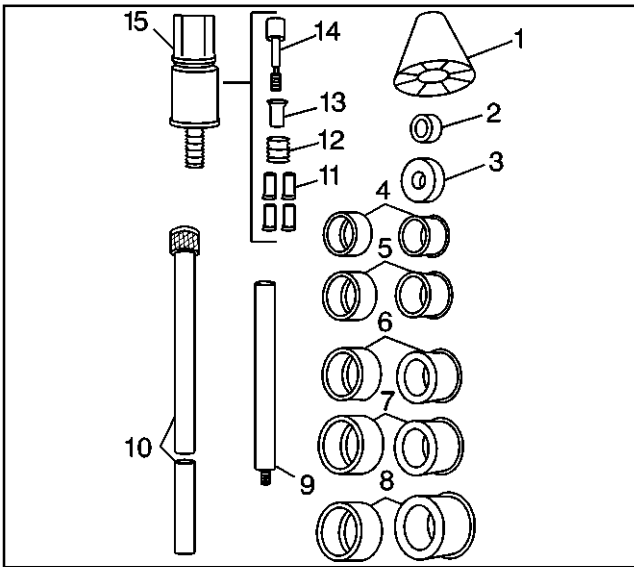

66100

3. Select the expanding driver (4-8) and washer (2 or 3) from the J 33049.
4. Assemble the J 33049.

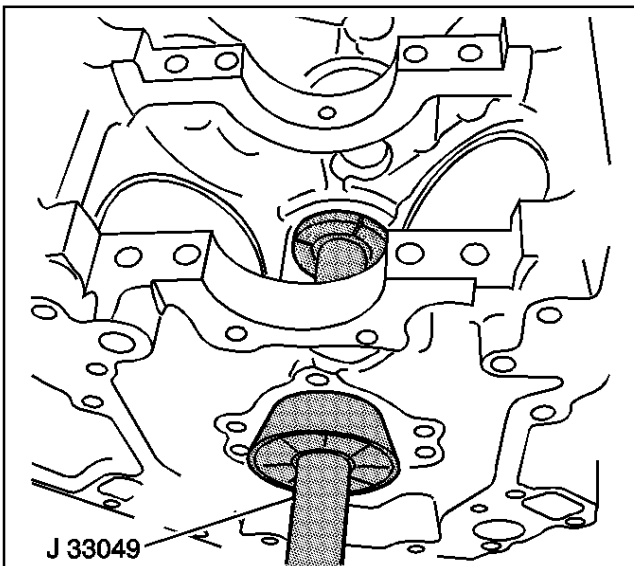

64183

**Important:** Remove the inner bearings (positions 2,3 and 4) first. The outer bearings (positions 1 and 5) serve as a guide for the J 33049.

5. Insert the J 33049 through the front of the engine block and into the bearing.
6. Tighten the expander assembly nut (15) until snug.
7. Push the guide cone (1) into the front camshaft bearing (position 1) to align the J 33049.
8. Drive the inner bearings (positions 2,3 and 4) from their block bores.

9. Assemble the J 33049 handle (10), expanding driver (4-8) and washer (2 or 3).
10. Insert the J 33049 into the outer camshaft bearings (positions 1 or 5).
11. Drive the outer bearings (positions 1 or 5) from the bore.

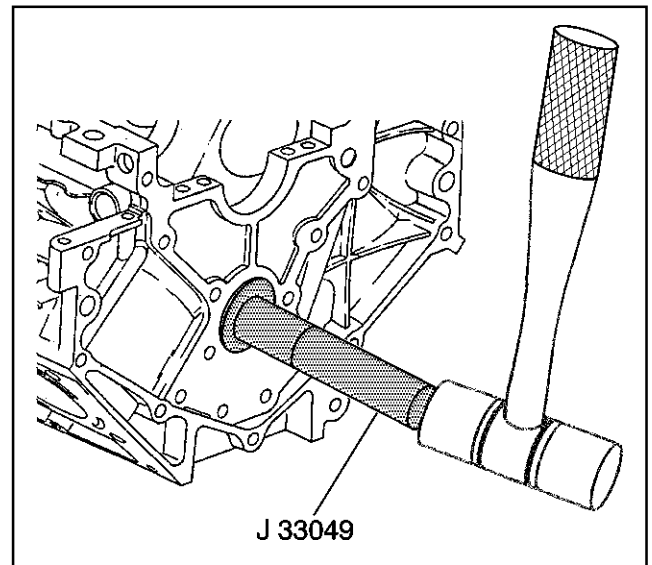

63219

**Engine Block Clean and Inspect**

1. Boil the cylinder block in caustic solution.
2. Flush the cylinder block with clean water or steam.
3. Clean the following areas:
  - All gasket surfaces; Refer to *Replacing Engine Gaskets*
  - Cylinder bores; remove excessive cylinder ring ridge as required
  - Main bearing caps
  - Oil galleries; remove all sludge or restrictions
  - Scale deposits from the coolant passages
  - All dirt or debris from the threaded bolt holes

**Caution: Wear safety glasses in order to avoid eye damage.**

4. Dry the block with compressed air.
5. Lubricate the cylinder bores with clean engine oil to prevent rusting.
6. Inspect the engine block for the following conditions:
  - Gasket surfaces for deep gouges or other damage
  - Crankshaft bearing bores for wear
    - The surfaces where the crankshaft bearings contact the crankshaft bearing bore must be smooth.
    - All crankshaft bearing bores must be round and uniform in inside diameter (ID) at all the bearing supports.
    - If a crankshaft bearing cap is damaged and requires replacement, refer to *Crankshaft and Bearings Clean and Inspect*.
  - Camshaft bearing bores for wear or damage
  - Valve lifter bores for scuffing or wear

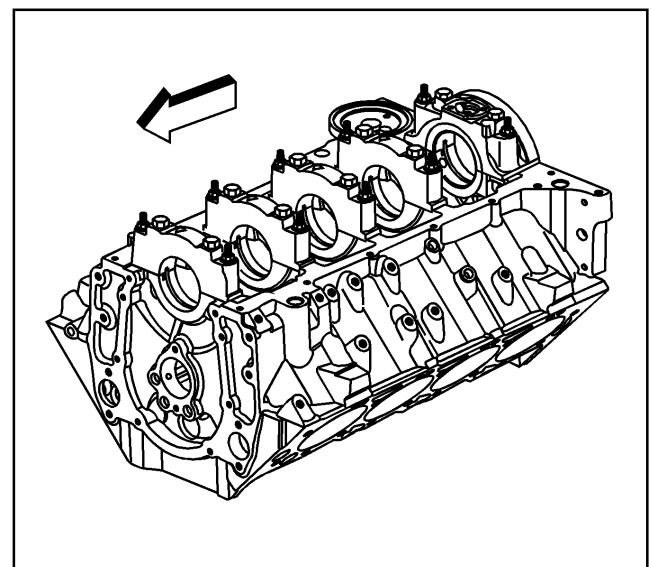

635662

- Engine block for cracks or other damage
- Cylinder walls for scoring or gouges
- Coolant jackets for cracks
- Crankshaft bearing webs for cracks
- Engine mount bosses for damage
- The oil passages for restrictions

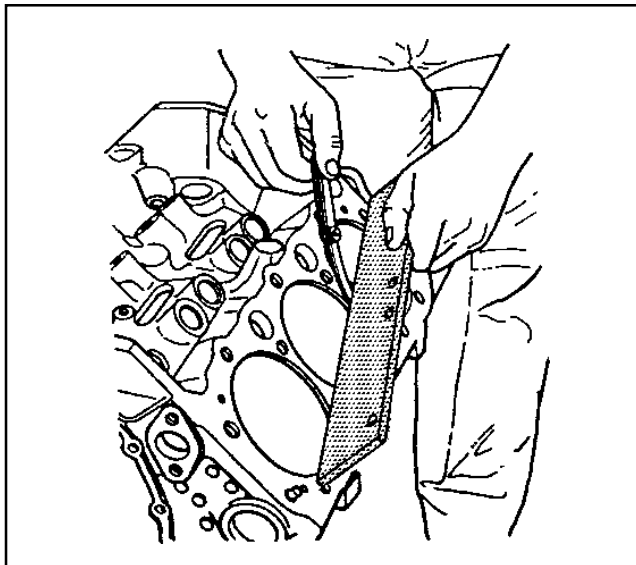

35209

7. Inspect the engine block cylinder head deck for flatness using a straight edge and a feeler gauge. The surface must be flat within 0.10 mm (0.004 in).

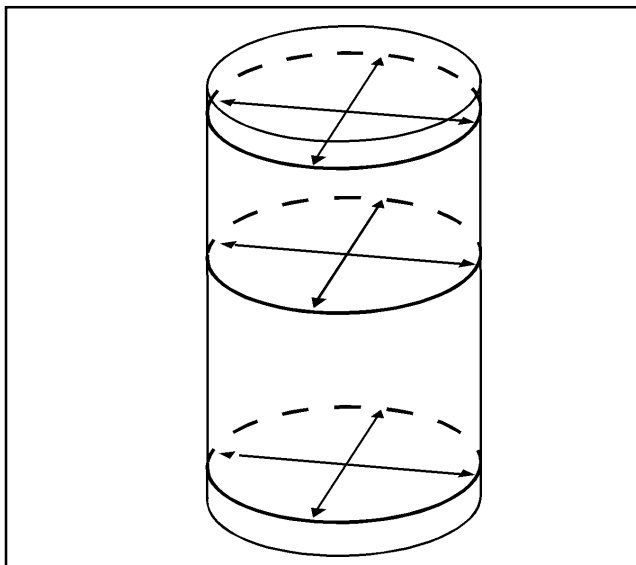

719134

8. Use a bore gauge and measure the cylinder bore for taper, out-of-round and oversize. Slide the bore gauge up and down throughout the length of the cylinder bore. Check the bore both parallel and perpendicular to the centerline of the crankshaft at the top, center and bottom of the bore. A cylinder bore that measures 107.940-107.990 mm (4.249-4.251 in) may be honed and serviced with a standard size piston/connecting rod assembly. A cylinder bore that exceeds the maximum diameter must be serviced with an oversized piston/connecting rod assembly.

## Cylinder Boring and Honing

### Cylinder Boring Procedure

1. Before you start the honing or boring operation, measure all new pistons with the micrometer contacting at points exactly 90 degrees from the piston pin centerline.

**Important:** If you do not check the cylinder block, the boring bar may be tilted. This may result in incorrect rebored cylinder wall to crankshaft angle.

2. Before you use any type of boring bar, file the top of the cylinder block in order to remove any dirt or burrs.
3. Carefully follow the instructions furnished by the manufacturer regarding use of the equipment.
4. When you rebore cylinders, make sure all crankshaft bearing caps are in place.
  - Tighten the bearing caps to the proper torque in order to avoid distortion of the bores in the final assembly.
  - The crankshaft must be removed prior to cylinder boring.
5. When you take the final cut with a boring bar, leave 0.03 mm (0.001 in) on the diameter for finish honing. This gives the required position to the cylinder clearance specifications. (Carefully perform the honing and boring operation in order to maintain the specified clearances between pistons, rings and cylinder bores).

### Cylinder Honing Procedure

**Important:** Always remove all bearings and components from the engine block before cleaning, boring or honing the engine block.

1. When honing the cylinders, follow the manufacturer's recommendations for equipment use, cleaning and lubrication.
  - Use only clean, sharp stones of the proper grade for the amount of material you remove.
  - Dull, dirty stones cut unevenly and generate excessive heat.
  - Do not hone to a final grade with a coarse or medium-grade stone.
  - Leave sufficient metal so that all stone marks may be removed with final grade stones.
  - Perform final honing with a fine-grade stone and hone the cylinder in a cross hatch pattern at 45 to 65 degrees to obtain the proper clearance.
2. During the honing operation, thoroughly clean the cylinder bore.
  - Repeatedly check the cylinder bore for fit with the selected piston.
  - All measurements of the piston or the cylinder bore should be made with the components at normal room temperature.

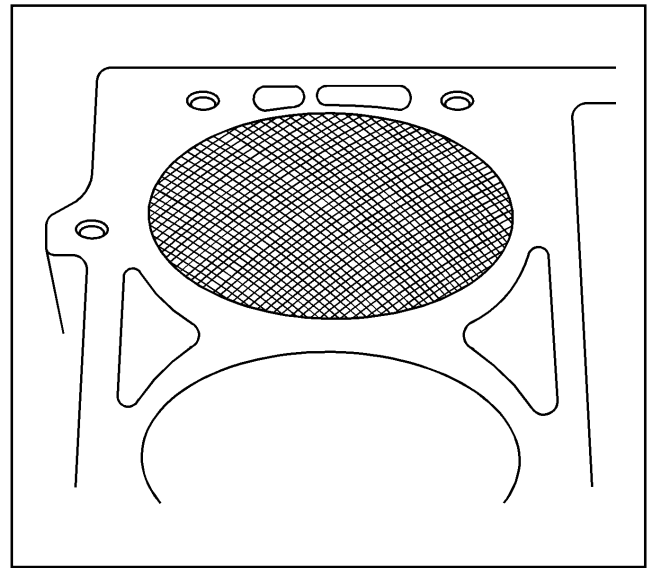

186747

3. When honing to eliminate taper in the cylinder, make full strokes of the hone in the cylinder. Repeatedly check the measurement at the top, the middle and the bottom of the bore.
  - The finish marks should be clean but not sharp.
  - The finish marks should be free from imbedded particles and torn or folded metal.
4. When finished, the reconditioned cylinder bores should have less than or meet the specified out-of-round or taper requirements.
5. After final honing and before the piston is checked for fit, clean the bores with hot water and detergent.
  - 5.1. Scrub the bores with a stiff bristle brush and rinse the bores thoroughly with hot water. Do not allow any abrasive material to remain in the cylinder bores.
    - Abrasive material may cause premature wear of new piston rings and cylinder bores.
    - Abrasive material will contaminate the engine oil and may cause premature wear of the bearings.
  - 5.2. After washing the cylinder bore, dry the bore with a clean shop towel.
6. Perform final measurements of the piston and cylinder bore.
7. Permanently mark the piston for the specific cylinder to which it has been fitted.
8. Apply clean engine oil to each cylinder bore in order to prevent rusting.

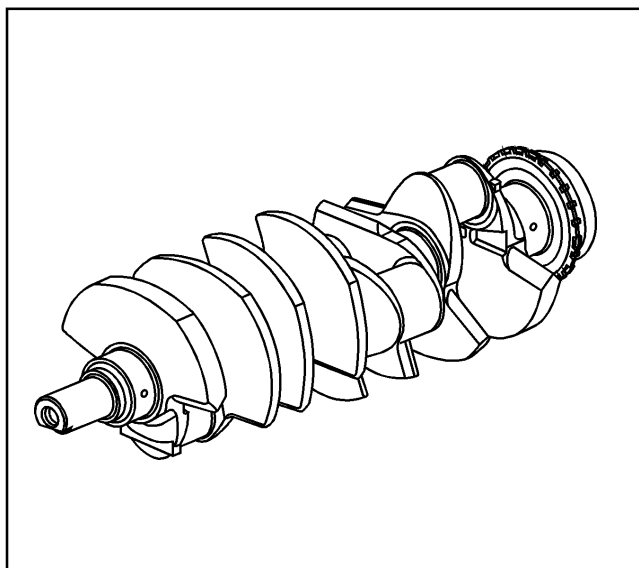

639519

## Crankshaft and Bearings Clean and Inspect

### Crankshaft Inspection

#### Tools Required

*J 7872* Magnetic Base Dial Indicator

*J 36660-A* Electronic Torque Angle Meter

### Crankshaft Inspection

**Important:** Use care when handling the crankshaft. Avoid damage to the bearing surfaces.

1. Clean the crankshaft in solvent. Remove all sludge or restrictions from the oil passages.

**Caution:** *Wear safety glasses in order to avoid eye damage.*

2. Dry the crankshaft and bearings with compressed air.



3. Inspect the crankshaft for the following conditions:
  - Crankshaft journals (1) should be smooth with no evidence of scoring or damage
  - Deep grooves (2)
  - Scratches or uneven wear (3)
  - Pitted surfaces (4)
  - Wear or damage to the thrust journal surfaces
  - Scoring or damage to the rear seal surface
  - Restrictions to oil passages
  - Damage to threaded bolt holes

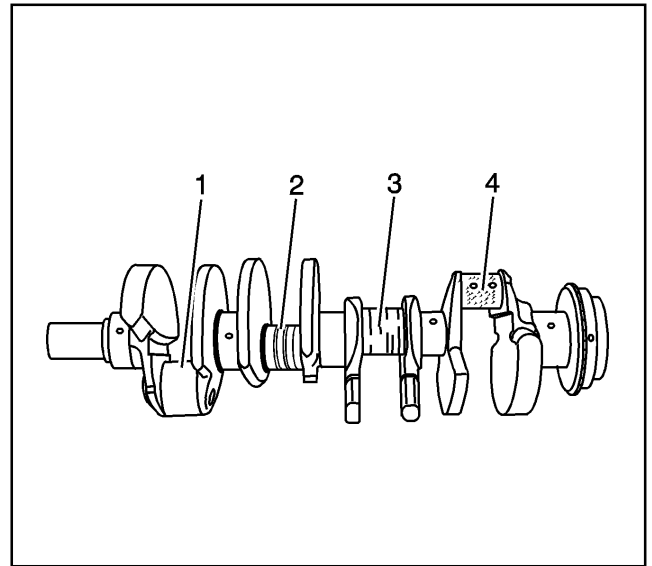

677825

**Important:** The crankshaft pin is a pressed in roll pin. The pin only needs to be removed from the crankshaft if the pin is damaged.

4. Inspect the crankshaft pin for damage:
  - Measure for proper installed height.
  - Replace the crankshaft pin if it is damaged.

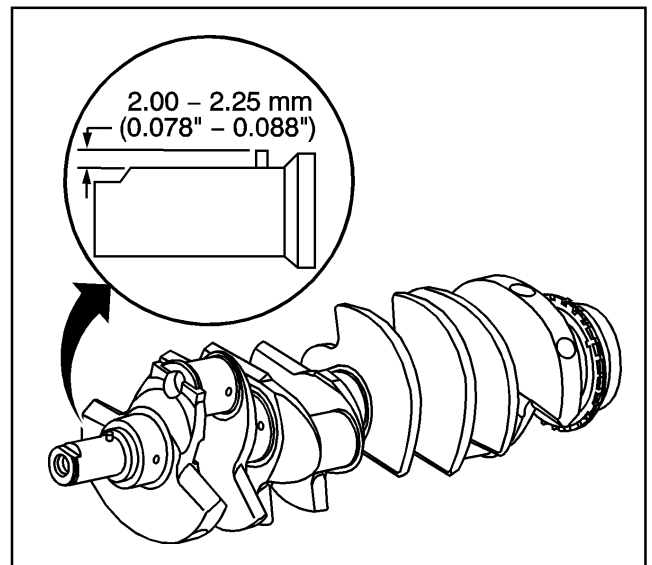

639543

**Important:** DO NOT attempt to remove the crankshaft reluctor wheels. If the reluctor wheels are damaged and/or removed, the crankshaft must be replaced.

5. Inspect the reluctor wheels for cracked, bent or broken teeth.
  - Measure between the crankshaft shoulder and the front reluctor wheel (1).
  - Measure between the front and rear reluctor wheels (2).
  - The maximum allowable gap is 0.15 mm (0.006 in).

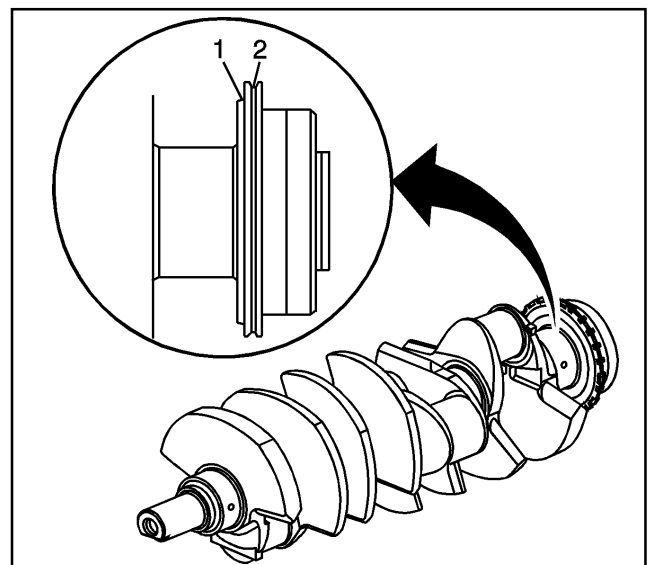

677772

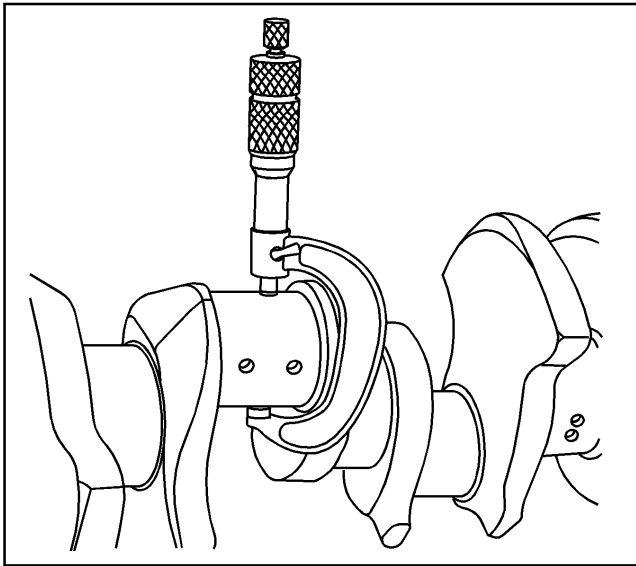

35207

6. Measure the crankshaft main journals and the crankpins to out-of-round and taper.

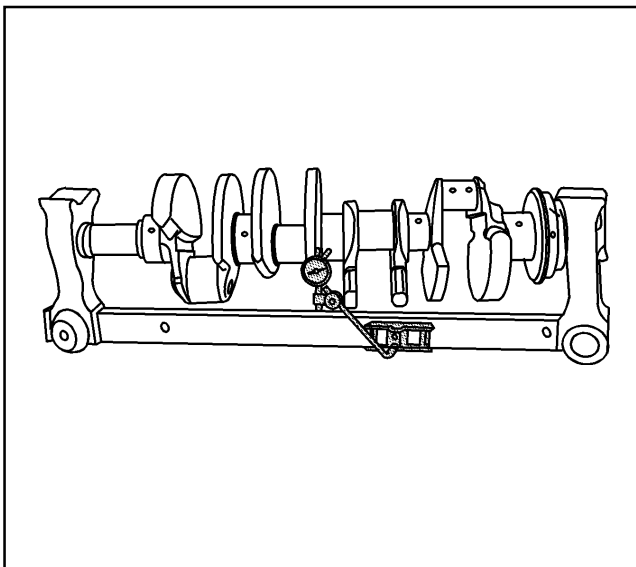

677818

7. Using a suitable fixture, support the crankshaft.
  - 7.1. Measure the crankshaft runout using J 7872.
  - 7.2. Crankshaft runout should not exceed 0.051 mm (0.002 in).

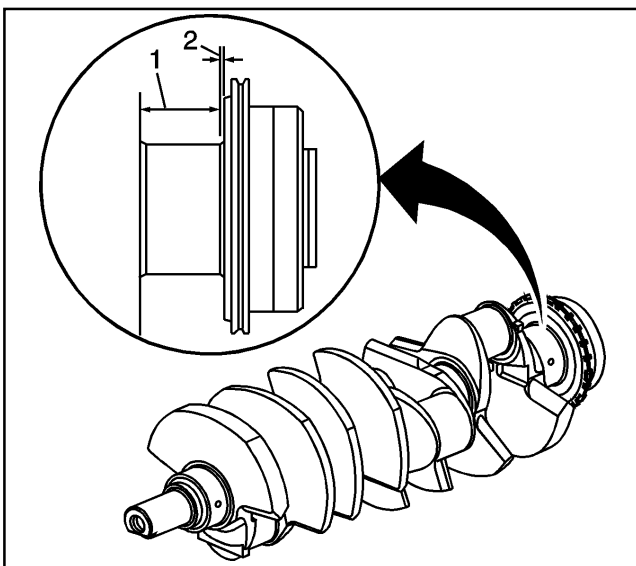

639520

8. Inspect the crankshaft thrust wall surface for wear (1) and/or excessive runout (2). Refer to *Engine Mechanical Specifications*.

**Crankshaft and Connecting Rod Bearing Inspection**

**Notice:** Do not shim, scrape or file bearing inserts. Do not touch the bearing surface of the insert with bare fingers. Skin oil and acids will etch the bearing surface.

1. Inspect the bearings for craters or pockets.  
Flattened sections on the bearing halves also indicate fatigue.

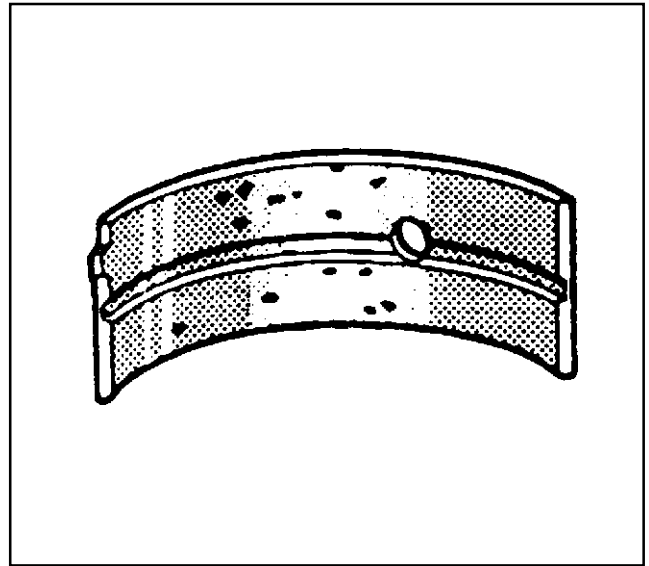

52051

2. Inspect the bearings for excessive scoring or discoloration.
3. Inspect the bearings for dirt or debris imbedded into the bearing material.

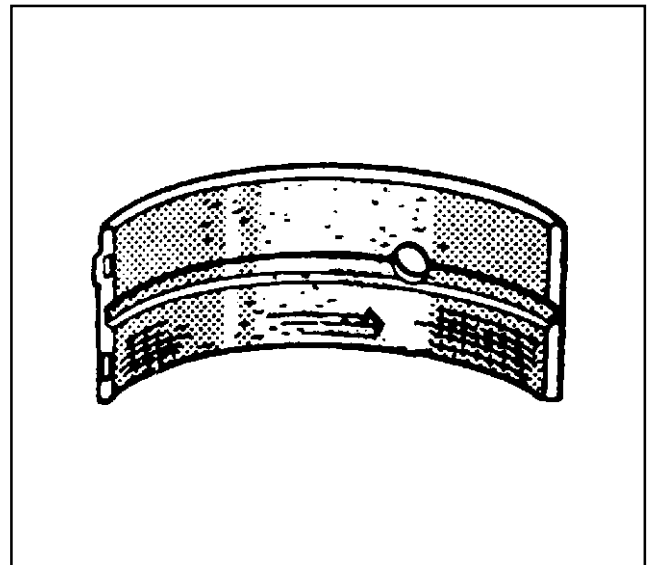

52053

4. Inspect the bearings for improper seating indicated by bright, polished sections of the bearings.

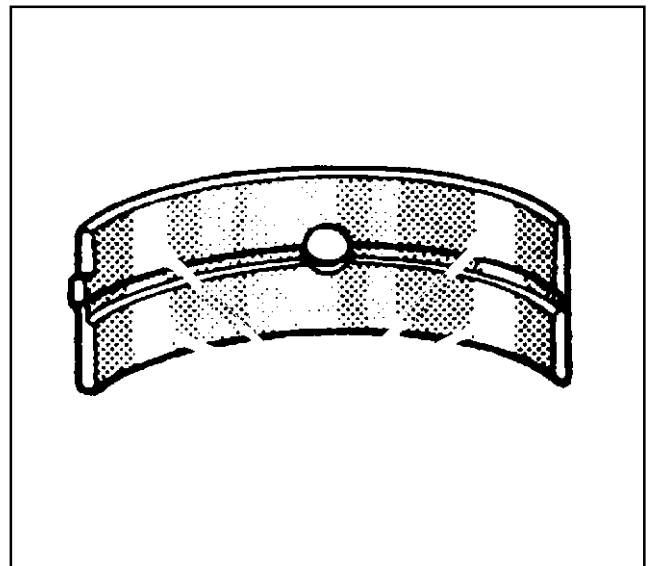

52056

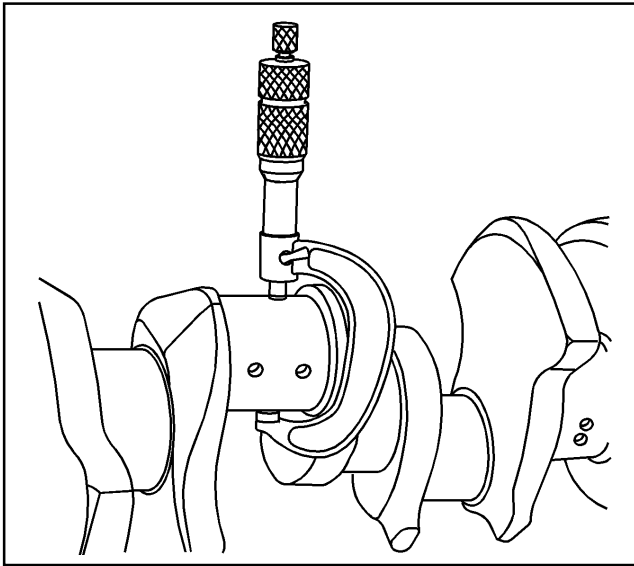

35207

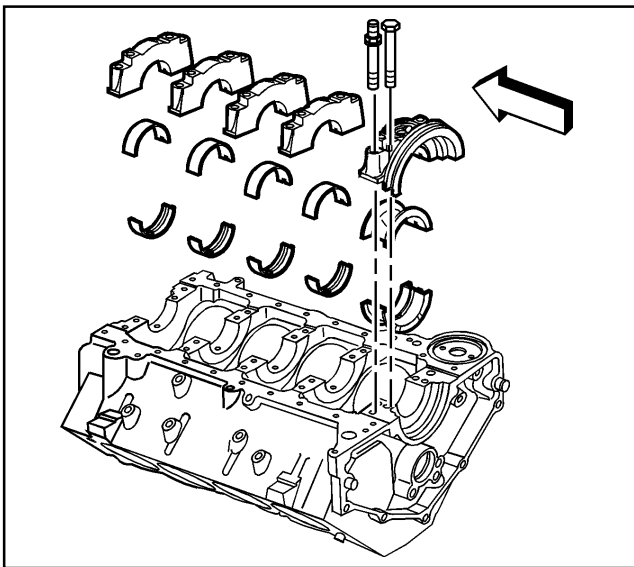

639521

## Crankshaft and Connecting Rod Bearing Clearance Measurement

The crankshaft and connecting rod bearings are of the precision insert type and do not use shims for adjustment. If the clearances are excessive, the new upper and the lower bearings will be required. The service bearings are available in the standard size and an undersize.

The selective fitting of the bearings are necessary in production in order to obtain close tolerances. For this reason, in one journal bore you may use one-half of a standard bearing with one-half of an undersize bearing.

In order to determine the correct replacement bearing size, the bearing clearance must be measured accurately. Either the micrometer or plastic gauge method may be used, however, the micrometer method gives more reliable results and is preferred.

## Micrometer Method for Crankshaft Bearings

### Tools Required

J 36660-A Electronic Torque Angle Meter

1. Measure the crankshaft main journal diameter with a micrometer in several places along the length approximately 90 degrees apart, (minimum of 4 places), and average the measurements.
2. Determine the taper and the out-of-round. Refer to *Engine Mechanical Specifications*.

**Notice:** Do not shim, scrape or file bearing inserts. Do not touch the bearing surface of the insert with bare fingers. Skin oil and acids will etch the bearing surface.

3. Install the crankshaft bearings into the crankshaft bearing caps and the engine block.

**Notice:** Refer to *Fastener Notice* in Cautions and Notices.

**Important:** Tighten the inner crankshaft bearing cap bolts before tightening the outer crankshaft bearing cap studs.

4. Install the crankshaft bearing caps and the crankshaft bearing cap bolts and studs.

### Tighten

- 4.1. Tighten the crankshaft bearing cap inner bolts to 30 N·m (22 lb ft).
- 4.2. Tighten the crankshaft bearing cap outer studs to 30 N·m (22 lb ft).
- 4.3. Using the J 36660-A, tighten the crankshaft bearing cap inner bolts an additional 90 degrees.
- 4.4. Using the J 36660-A, tighten the crankshaft bearing cap outer studs an additional 80 degrees.
5. Measure the crankshaft bearing inside diameter (ID) using an inside micrometer. Measure at a minimum of four places and average the measurements.
6. In order to determine the crankshaft bearing clearance, subtract the crankshaft journal diameter from the crankshaft bearing ID.

7. Compare the crankshaft bearing clearance to the specifications. Refer to *Engine Mechanical Specifications*.
8. If the crankshaft bearing clearances exceeds specifications, install the new crankshaft bearings.
9. Measure the new crankshaft bearing inside diameter (ID) using an inside micrometer.
10. Replace or repair the crankshaft if the proper clearances cannot be obtained.

**Micrometer Method for Connecting Rod Bearings**

**Tools Required**

J 36660-A Electronic Torque Angle Meter

1. Measure the crankpin diameter with a micrometer in several places along the length approximately 90 degrees apart, (minimum of 4 places), and average the measurements.
2. Determine the taper and the out-of-round. Refer to *Engine Mechanical Specifications*.

**Notice:** Do not shim, scrape or file bearing inserts. Do not touch the bearing surface of the insert with bare fingers. Skin oil and acids will etch the bearing surface.

3. Install the connecting rod bearings into the connecting rod cap and the connecting rod.

**Notice:** Refer to *Fastener Notice* in Cautions and Notices.

**Important:** Use the original connecting rod nuts for clearance measurement. During final assembly, new connecting rod nuts must be used to obtain correct fastener tightening.

4. Install the connecting rod cap and the original (used) nuts.

**Tighten**

Tighten the connecting rod nuts to 30 N·m (22 lb ft). Using the J 3660-A, tighten the connecting rod nuts an additional 90 degrees.

5. Measure the connecting rod bearing inside diameter (ID) using an inside micrometer.
6. Compare the connecting rod bearing clearance specifications. Refer to *Engine Mechanical Specifications*.
7. If the connecting rod bearing clearance is within specifications, the connecting rod bearing is satisfactory.
  - If the clearance is not within specifications, replace the connecting rod bearing.
  - Always replace both the upper and lower connecting rod bearings as an assembly.
8. A standard or undersize connecting rod bearing combination may result in the proper clearance. If the proper connecting rod bearing clearance cannot be achieved using a standard or the undersize connecting rod bearings, it will be necessary to replace or repair the crankshaft.

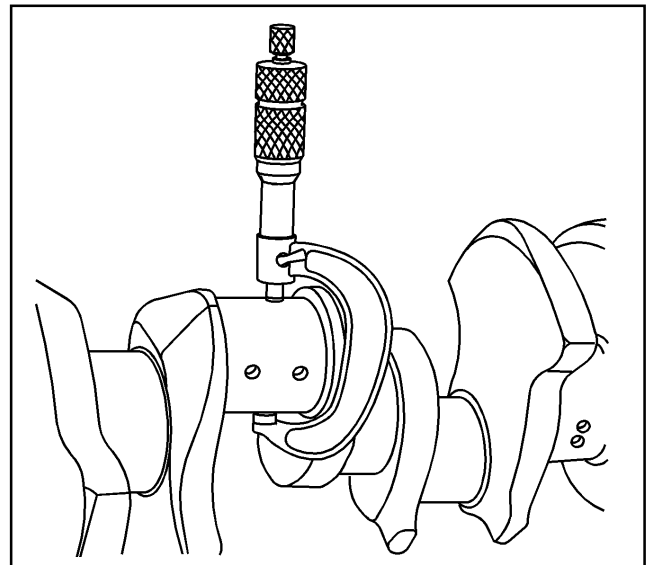

35207

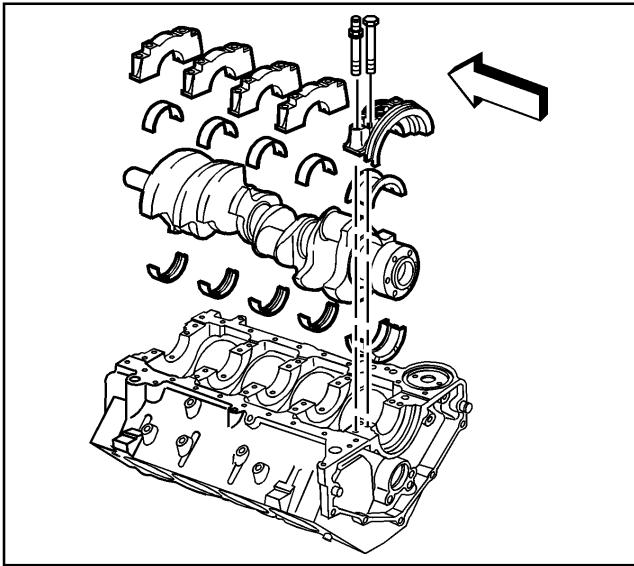

639522

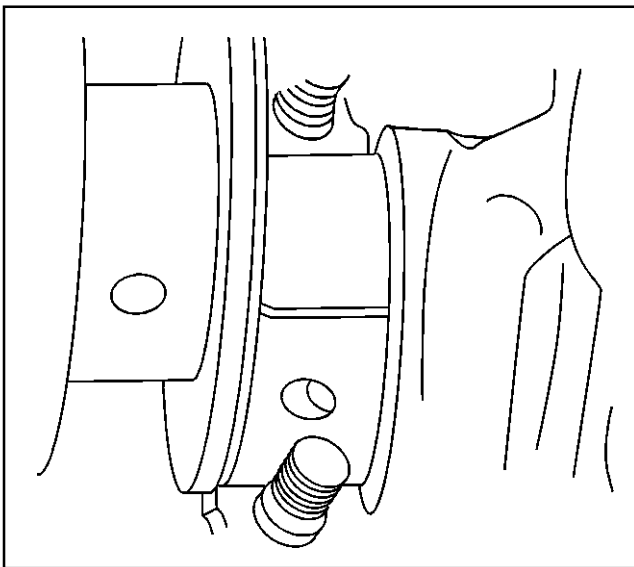

4980

### Plastic Gauge Method for Main Bearings

**Important:** When bearings are removed, NEW bearings must be installed during reassembly.

1. Install the crankshaft and crankshaft bearings into the engine block, making sure not to damage the reluctor rings of the crankshaft.

2. Install the gauging plastic the full width of the crankshaft journal.

**Notice:** Refer to *Fastener Notice* in Cautions and Notices.

**Important:** Tighten the inner crankshaft bearing cap bolts before tightening the outer crankshaft bearing cap studs. The crankshaft journal and the crankshaft bearing surface must be free from oil to obtain a correct measurement. Do not allow the crankshaft to rotate while performing the measurement, or an incorrect measurement will be obtained.

3. Install the crankshaft bearing caps and the crankshaft bearing cap bolts and studs.

#### Tighten

- 3.1. Tighten the crankshaft bearing cap inner bolts to 30 N·m (22 lb ft).
- 3.2. Tighten the crankshaft bearing cap outer studs to 30 N·m (22 lb ft).
- 3.3. Using the J 36660-A, tighten the crankshaft bearing cap inner bolts an additional 90 degrees.
- 3.4. Using the J 36660-A, tighten the crankshaft bearing cap outer studs an additional 80 degrees.
4. Remove the crankshaft bearing cap bolts and the crankshaft bearing caps. The gauging plastic may adhere to either the crankshaft journal or the crankshaft bearing surface.

5. On the edge of the gauging plastic envelope, there is a graduated scale. Without removing the gauging plastic, measure the compressed width at the widest point.
6. If the flattened gauging plastic tapers toward the middle or the ends, there may be a difference in clearance indicating taper, low spot or other irregularity of the crankshaft bearing or the crankshaft journal.
  - Normally, the crankshaft journals wear evenly and are not out-of-round. However, if a crankshaft bearing is being fitted to an out-of-round 0.0254 mm (0.001 in maximum) crankshaft journal, be sure to fit to the maximum diameter of the crankshaft journal.
  - If the crankshaft bearing is fitted to the minimum diameter and the crankshaft journal is excessively out-of-round, the interference between the crankshaft bearing and the crankshaft journal will result in rapid crankshaft bearing failure.
7. Compare the crankshaft bearing clearance to the specifications. Refer to *Engine Mechanical Specifications*.
8. If the crankshaft bearing clearances exceeds specifications, install undersize crankshaft bearings to achieve the correct clearance.
9. Measure the new crankshaft bearing inside diameter (ID) using the same method.
10. Replace or repair the crankshaft if the proper clearances cannot be obtained with available crankshaft bearings.
11. Remove the flattened gauging plastic.
12. Measure the remaining crankshaft journals.

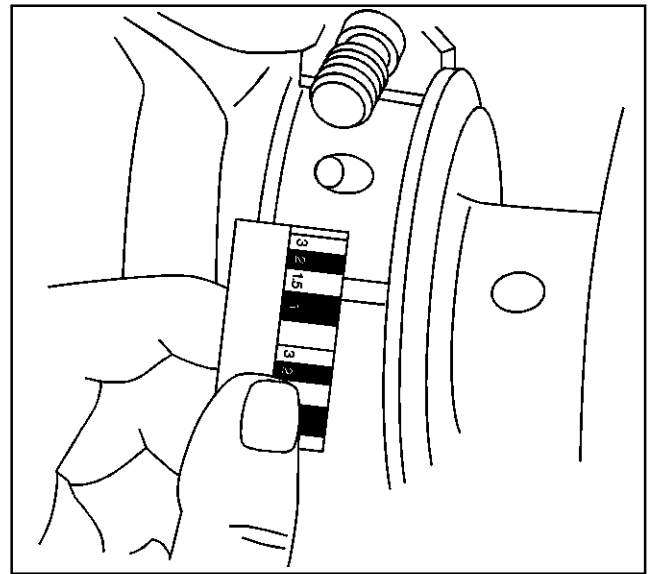

4981

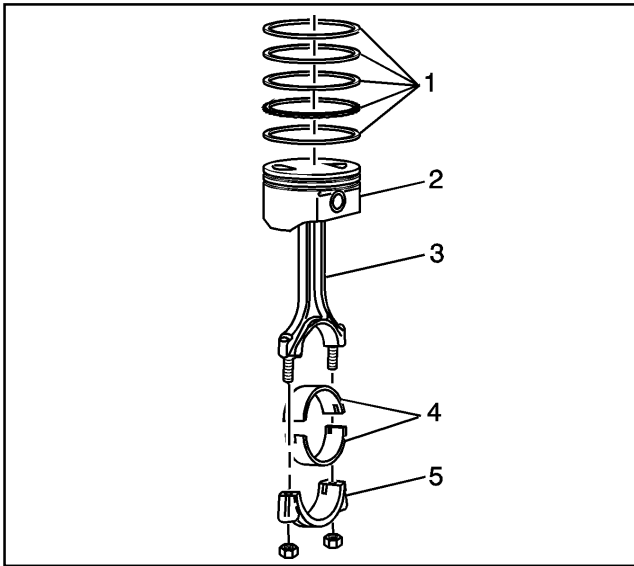

635669

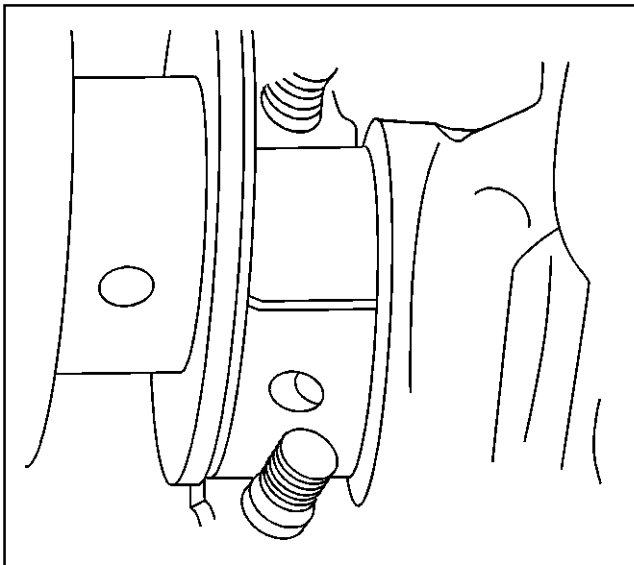

4980

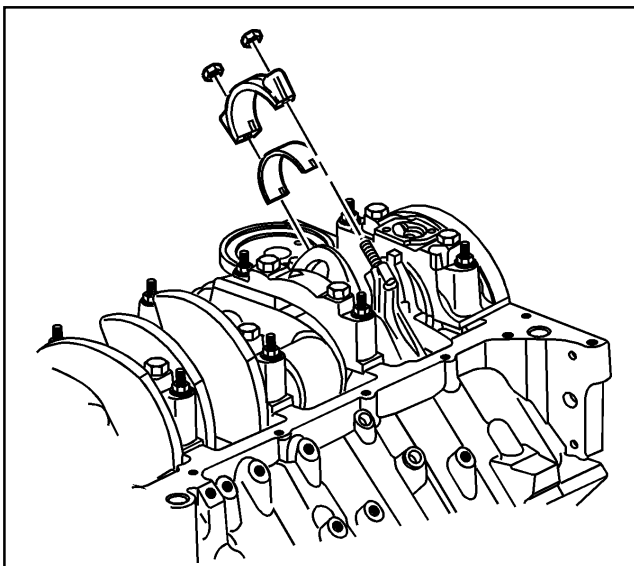

639084

### Plastic Gauge Method for Connecting Rod Bearings

#### Tools Required

J 36660-A Electronic Torque Angle Meter

**Important:** When bearings are removed, NEW bearings must be installed during reassembly.

1. Install the connecting rod bearings into the connecting rod and connecting rod cap.
2. Using rubber fuel line over the connecting rod bolts, install the piston and connecting rod assembly onto the crankpin journal.

3. Install the gauging plastic the full width of the crankpin journal.

**Notice:** Refer to *Fastener Notice* in Cautions and Notices.

**Important:** Use the original connecting rod nuts for clearance measurement. During final assembly, new connecting rod nuts must be used to obtain correct fastener tightening.

4. Install the connecting rod cap and the original (used) nuts.

#### Tighten

Tighten the connecting rod nuts to 30 N·m (22 lb ft). Using the J 36660-A, tighten the connecting rod nuts an additional 90 degrees.

5. Remove the connecting rod nuts and cap. The gauging plastic may adhere to either the crankpin journal or the connecting rod bearing surface.



6. On the edge of the gauging plastic envelope, there is a graduated scale. Without removing the gauging plastic, measure the compressed width at the widest point. If the flattened gauging plastic tapers toward the middle or the ends, there may be a difference in clearance indicating taper, low spot or other irregularity of the crankshaft bearing or the crankshaft journal.
7. Normally, the crankshaft journals wear evenly and are not out-of-round. However, if a connecting rod bearing is being fitted to an out-of-round 0.0254 mm (0.001 in maximum) crankpin journal, be sure to fit to the maximum diameter of the crankpin journal. If the connecting rod bearing is fitted to the minimum diameter and the crankpin journal is excessively out-of-round, the interference between the connecting rod bearing and the crankpin journal will result in rapid connecting rod bearing failure.
8. Compare the connecting rod bearing clearance to the specifications. Refer to *Engine Mechanical Specifications*.
9. If the connecting rod bearing clearances exceed specifications, install undersize connecting rod bearings to achieve the correct clearance.
10. A standard or undersize connecting rod bearing combination may result in the proper clearance. If the proper clearance cannot be achieved using the standard or the undersize connecting rod bearings, it may be necessary to repair or replace the crankshaft or connecting rod.
11. Remove the flattened gauging plastic.
12. Measure the remaining crankpin journals.

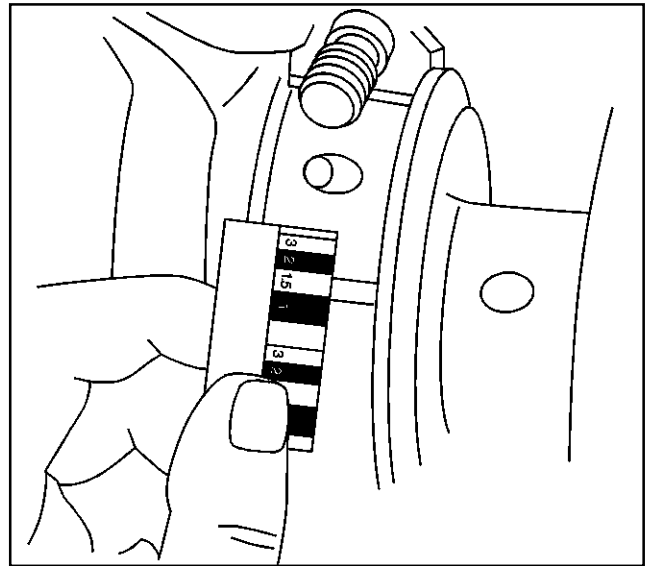

4981

### Measuring Crankshaft End Play

**Important:** In order to properly measure the crankshaft end play, the crankshaft, bearings, bearing caps and fasteners must be installed into the engine block and the bolts tightened to specifications. Refer to *Crankshaft and Bearings Installation*.

1. Install the J 7872 or equivalent to the cylinder block, with the dial indicator plunger against one of the counterweights of the crankshaft.
2. Firmly thrust the end of the crankshaft first rearward then forward. This will line up the rear crankshaft bearing and the crankshaft thrust surfaces.
3. With the crankshaft pushed forward, zero the dial indicator. Move the crankshaft rearward and read the endplay measurement on the dial indicator. An optional method is to insert a feeler gauge between the crankshaft and the bearing surface and measure the clearance. Refer to *Engine Mechanical Specifications*.

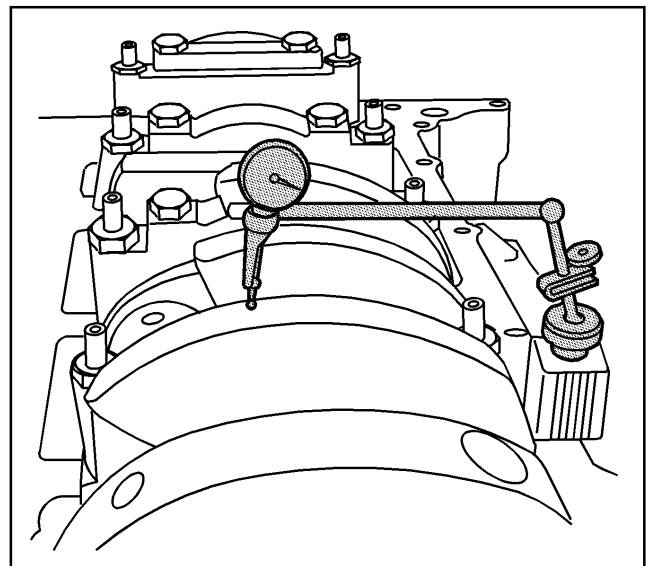

677804

4. If the correct end play cannot be obtained, inspect for the following conditions:
  - Verify that the correct size crankshaft bearing has been installed. Refer to *Engine Mechanical Specifications*.
  - Inspect the crankshaft thrust wall surface(s) for wear and/or excessive runout. Refer to J 7872.
5. Inspect the crankshaft for binding. Turn the crankshaft to check for binding. If the crankshaft does not turn freely, loosen the crankshaft bearing bolts, one cap at a time, until the tight bearing is located. The following condition(s) could cause a lack of clearance at the bearing:
  - Burrs on the crankshaft bearing cap
  - Foreign matter between the crankshaft bearing and the block or the crankshaft bearing cap
  - A faulty crankshaft bearing

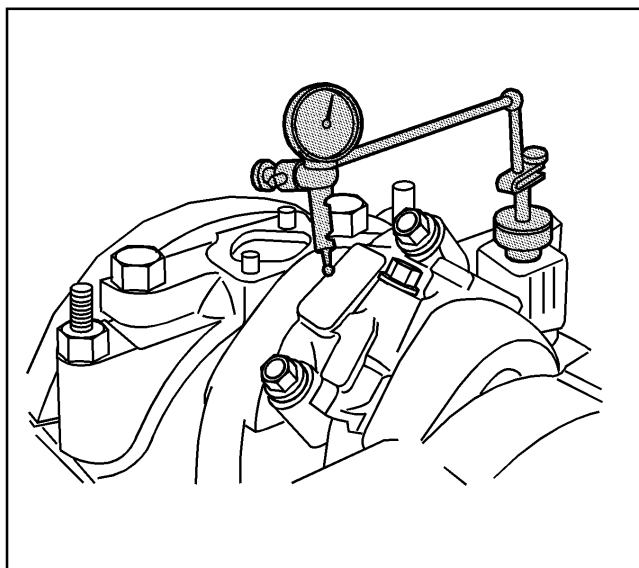

677801

### Measuring Connecting Rod Side Clearance

**Important:** In order to properly measure the connecting rod side clearance, the piston/connecting rod assembly and bearings must be installed into the engine block and the connecting rod nuts tightened to specifications. Refer to *Piston, Connecting Rod and Bearing Installation*.

1. Install the J 7872 or equivalent to the cylinder block, with the dial indicator plunger against the side of the pair of connecting rods.
2. With the connecting rods pushed forward, zero the dial indicator. Firmly move the pair of connecting rods side to side and read the measurement on the dial indicator. An optional method is to insert a feeler gauge between the connecting rod caps and measure the connecting rod side clearance. Refer to *Engine Mechanical Specifications*.

**Crankshaft Balancer Clean and Inspect**

1. Clean the crankshaft balancer in solvent.

**Caution:** *Wear safety glasses in order to avoid eye damage.*

2. Dry the crankshaft balancer with compressed air.
3. Inspect the crankshaft balancer for the following:
  - Damaged belt grooves (3)
  - Debris in the belt grooves (3)
  - Worn, grooved or damaged hub seal surface (1)
    - Minor imperfections on the hub seal surface may be removed with a polishing compound of fine grade of emery cloth.
    - A crankshaft balancer hub seal surface with excessive scoring, grooves, rust or other damage must be replaced.
  - Worn, chunking or deteriorated rubber between the hub and pulley (2)
4. Repair or replace the crankshaft balancer as necessary.

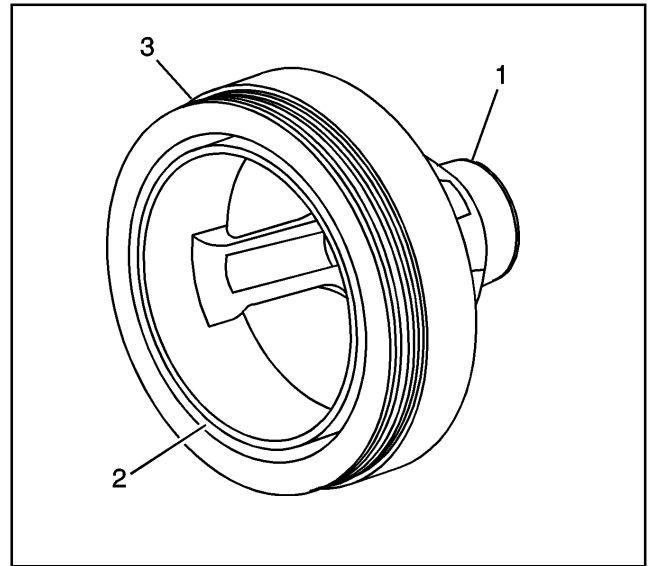

635666

**Engine Flywheel Clean and Inspect (A/T)**

1. Clean the engine flywheel in solvent.

**Caution:** *Wear safety glasses in order to avoid eye damage.*

2. Dry the engine flywheel with compressed air.
3. Inspect the engine flywheel for the following:
  - Stress cracks around the engine flywheel-to-torque converter mounting bolt hole locations (1) and/or engine flywheel-to-crankshaft (2,3)

**Important:** Do not attempt to repair the welded areas that retain the ring gear to the engine flywheel plate. Install a new engine flywheel.

- Cracks at welded areas that retain the ring gear onto the engine flywheel (4)
- Damaged or missing ring gear teeth (5)

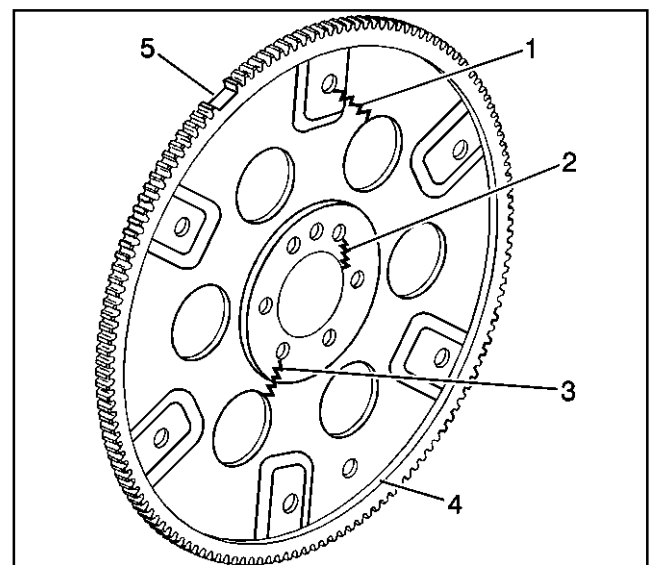

381965

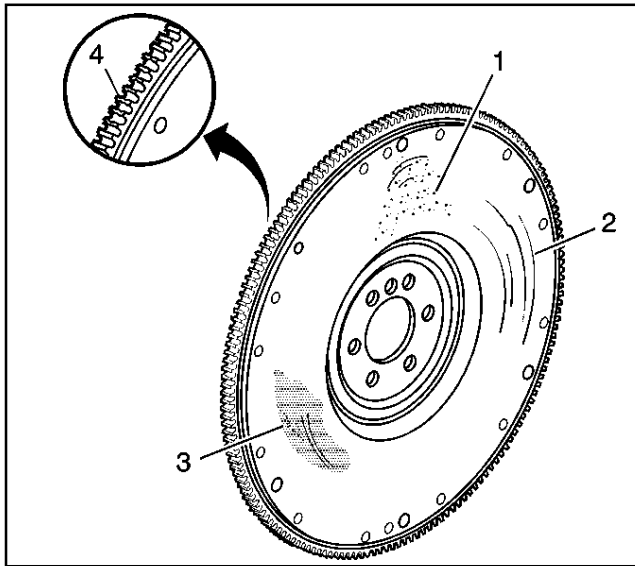

188086

### Engine Flywheel Clean and Inspect (M/T)

1. Clean the engine flywheel in solvent.

**Caution:** *Wear safety glasses in order to avoid eye damage.*

2. Dry the engine flywheel with compressed air.
3. Inspect the manual transmission engine flywheel for the following:

- Pitted surface (1)
- Scoring or grooves (2)
- Rust or other surface damage (3)
- Damaged ring gear teeth (4)

- Loose or improperly positioned ring gear

The ring gear has an interference fit onto the engine flywheel and should be positioned completely against the flange of the engine flywheel.

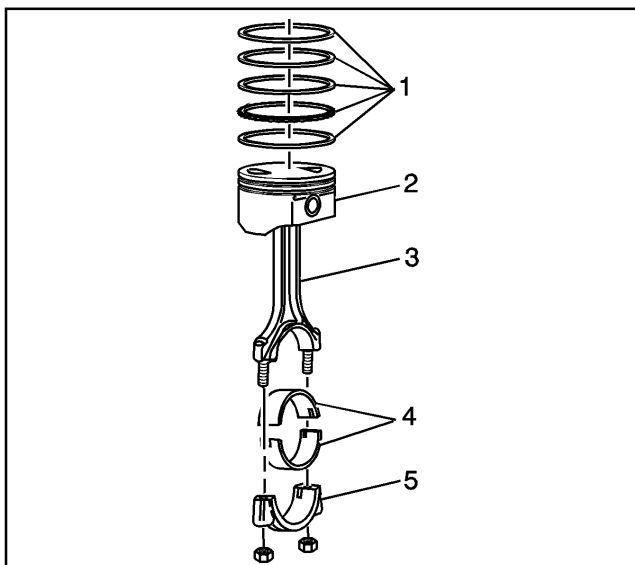

635669

### Piston and Connecting Rod Disassemble

**Important:** The piston and connecting rod are only serviced as an assembly. If a new piston or connecting rod is required, a complete piston/connecting rod assembly must be used.

**Important:** New connecting rod nuts must be used when pistons are reinstalled in the engine.

1. Remove the piston rings (1) from the piston (2).

**Piston, Connecting Rod and Bearings Clean and Inspect**

**Important:** The piston diameter can NOT be measured due to the piston coating. Do NOT measure the piston diameter.

**Important:** Measurement of all components should be taken with the components at room temperature.

Do not use a wire brush in order to clean any part of the piston.

1. Clean the piston (2), connecting rod (3) and connecting rod cap (5) in solvent.

**Caution: Wear safety glasses in order to avoid eye damage.**

2. Dry the components with compressed air.

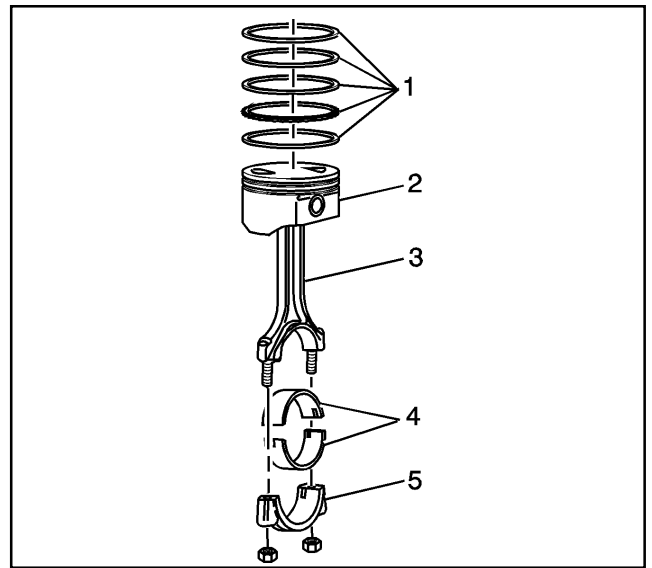

635669

3. Clean the piston ring grooves with a suitable ring groove cleaning tool.
4. Clean the piston oil lubrication holes and slots.

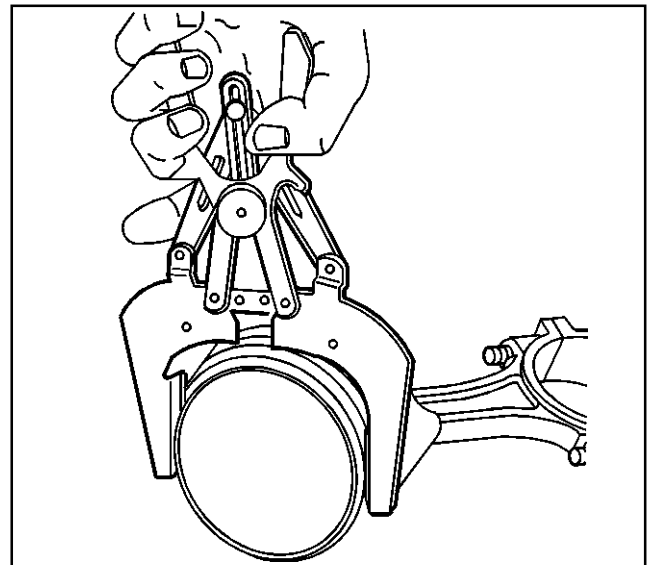

4977

5. Inspect the piston for the following:
  - Eroded areas (1) on the top of the piston
  - Scuffed or damaged skirt (2)
  - Cracks in the piston ring lands, the piston skirt or the pin bosses
  - Piston ring grooves for nicks, burrs or other warpage which may cause the piston ring to bind
6. Inspect the piston pin for scoring, wear or other damage.

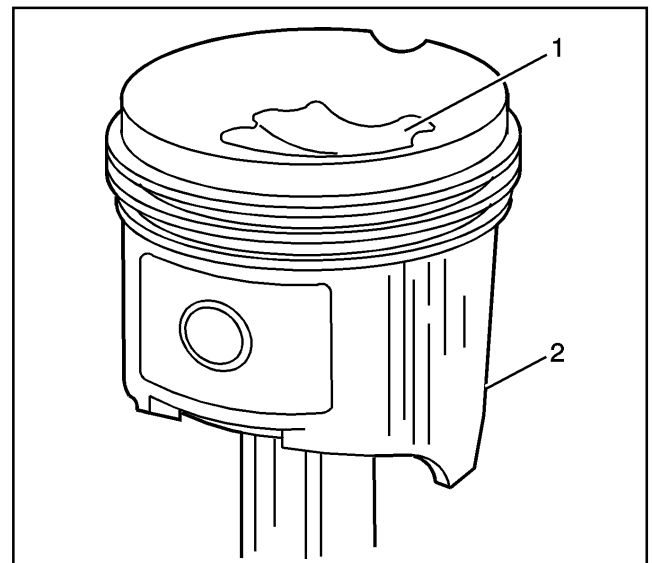

639530

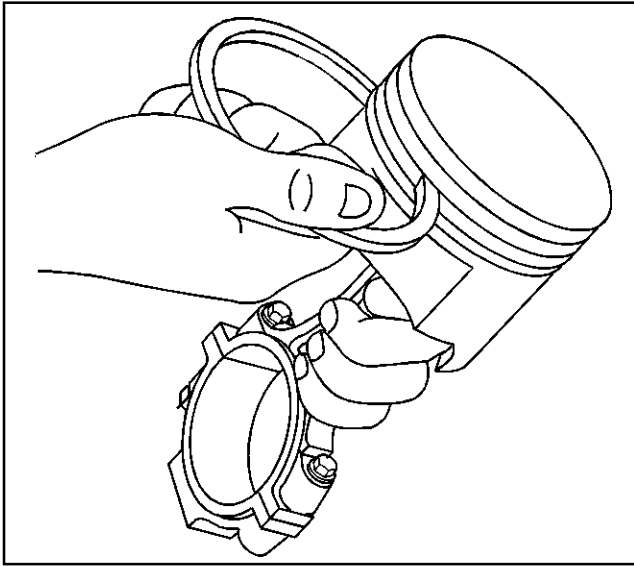

4969

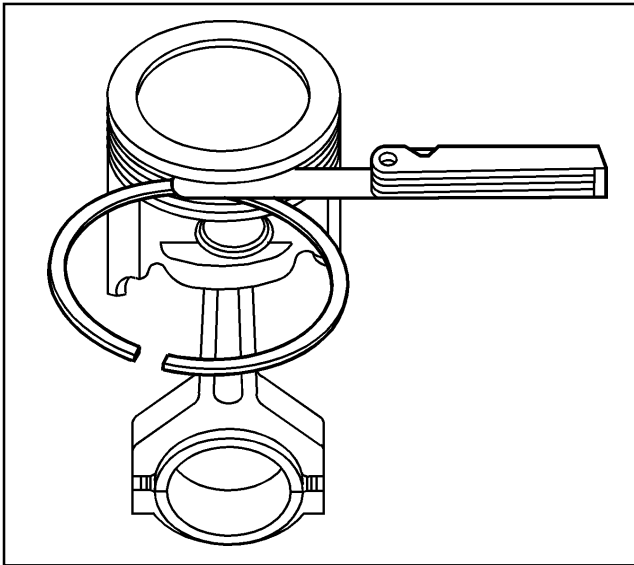

639528

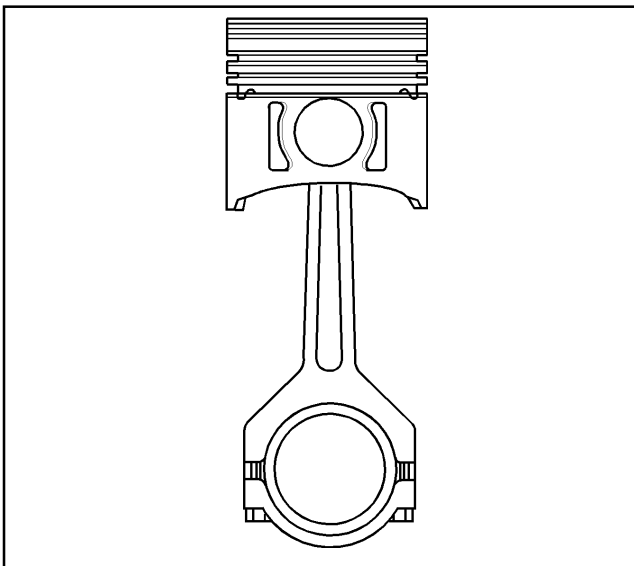

639526

7. Measure the piston ring-to-piston ring groove side clearance. Refer to *Engine Mechanical Specifications*.
  - 7.1. Insert the edge of the piston ring into the piston ring groove.  
Roll the piston ring completely around the piston.
  - 7.2. If binding is caused by a distorted piston ring groove, MINOR imperfections may be removed with a fine file.
  - 7.3. If binding is caused by a distorted piston ring, replace the piston ring.

8. Measure the piston ring side clearance with a feeler gauge.
9. If the side clearance is too small, try another piston ring set. Refer to *Engine Mechanical Specifications*.
10. If the proper piston ring-to-piston ring groove clearance cannot be achieved, replace the piston and pin assembly.

11. Inspect the connecting rod for an out-of-round bearing bore.

12. Inspect the connecting rod for twisting.
13. Inspect the connecting rod for damage to the connecting rod bolt threads.

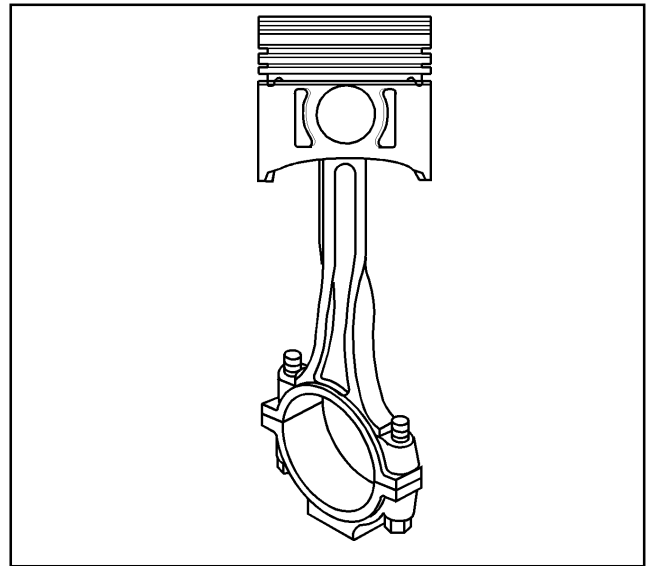

639524

**Important:** Fit each compression ring to the cylinder in which it will be used.

14. Measure the piston compression ring end gap.
  - 14.1. Place the compression ring into the cylinder bore.
  - 14.2. Push the compression ring into the cylinder bore to approximately 6.5 mm (0.25 in) above the ring travel.
  - 14.3. Use a feeler gauge in order to measure the end gap.
  - 14.4. Select another size ring set if the end gap exceeds specifications.

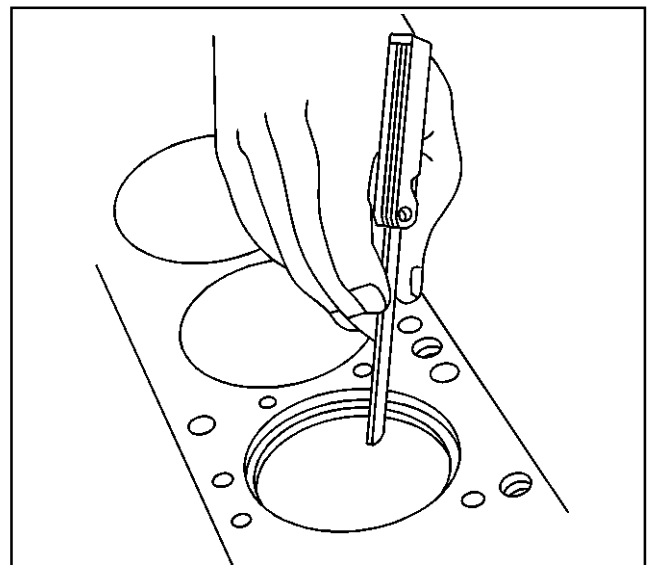

4968

**Piston and Connecting Rod Assemble**

**Notice:** Use a piston ring expander to install the piston rings. The rings may be damaged if expanded more than necessary.

1. Install the lower oil control piston ring spacer onto the piston.

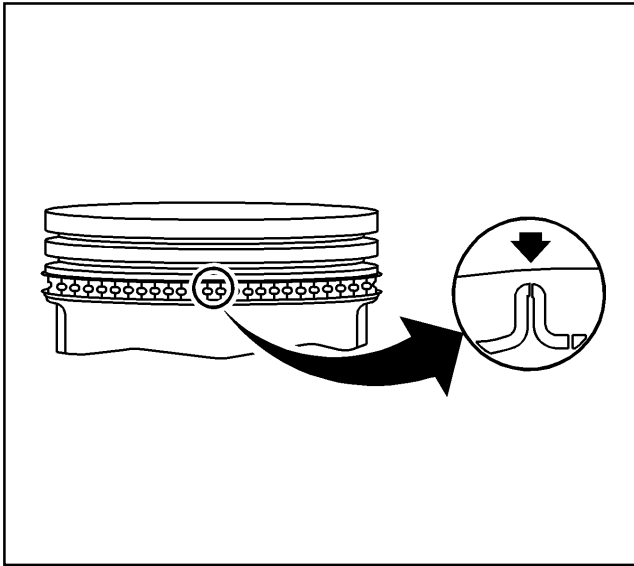

562836

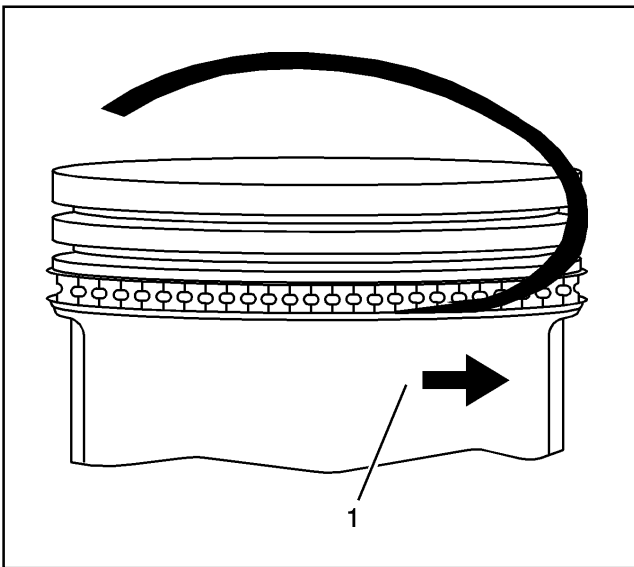

562842

2. Install the lower oil control piston ring onto the piston (1).

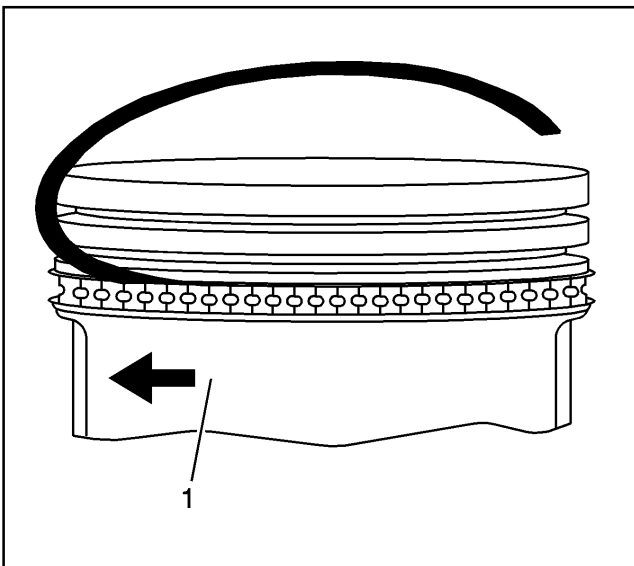

562839

3. Install the upper oil control piston ring onto the piston (1).



- 4. Space the oil control piston ring end gaps a minimum of 90 degrees apart.

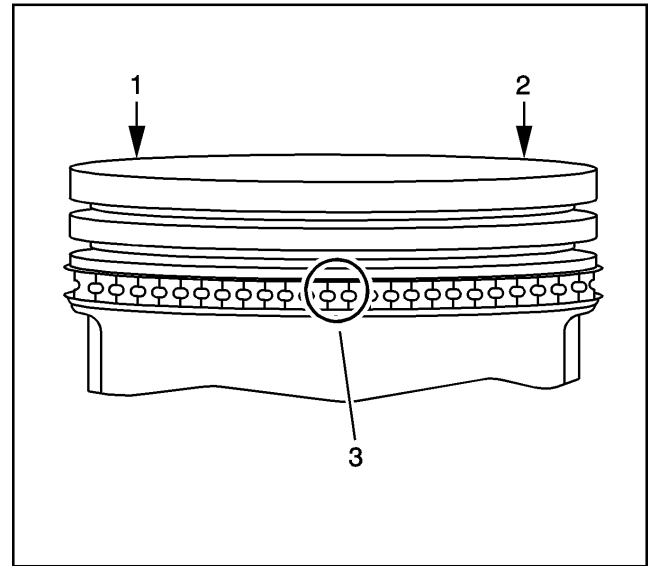

562848

- 5. Install the lower compression piston ring onto the piston. The mark (1) on the side of the piston ring should face the top of the piston.

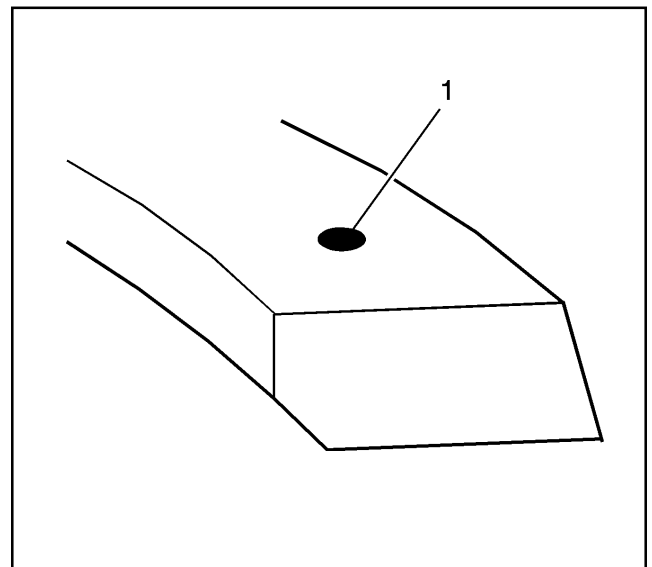

562823

- 6. Install the upper compression piston ring onto the piston. The mark (1) on the side of the piston ring should face the top of the piston.
- 7. Space the compression piston ring end gaps 120 degrees apart.

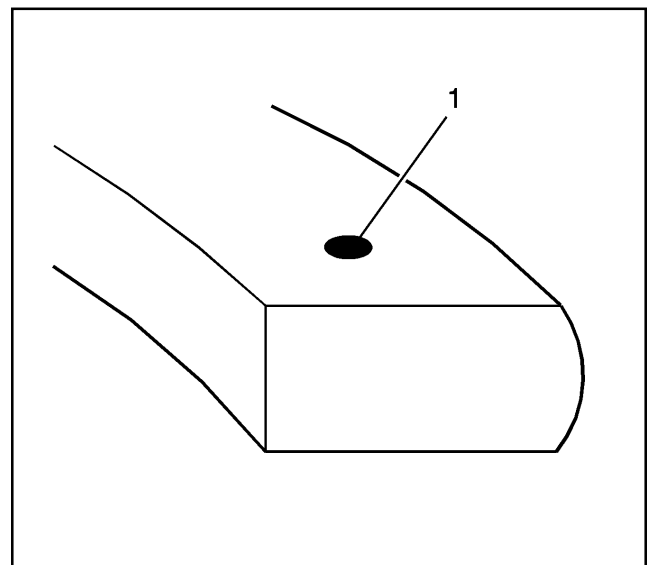

562819

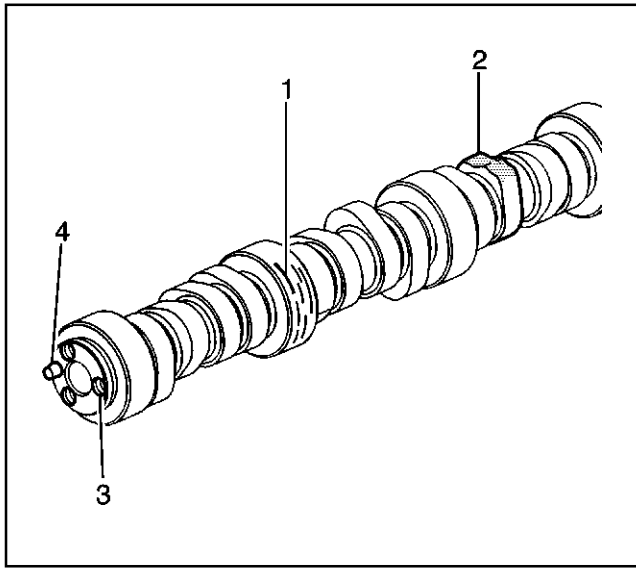

188095

## Camshaft and Bearings Clean and Inspect

### Tools Required

J 7872 Magnetic Base Dial Indicator

1. Clean the camshaft in solvent.

**Caution: Wear safety glasses in order to avoid eye damage.**

2. Dry the camshaft with compressed air.
3. Inspect the camshaft retainer plate for damage.
4. Inspect the camshaft for the following:
  - Camshaft bearing journals (1) that are:
    - Worn
    - Scored
    - Damaged
  - Worn camshaft lobes (2)
  - Damaged sprocket bolt threads (3)
  - Damaged sprocket pin (4)

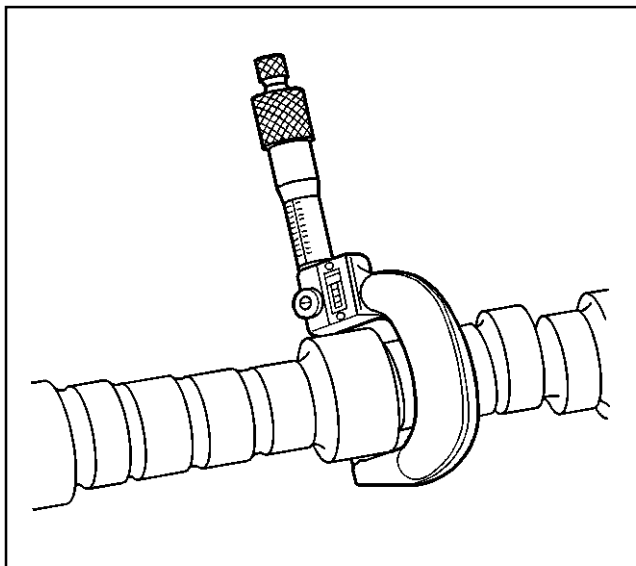

35212

5. Measure the camshaft journals with a micrometer. Refer to *Engine Mechanical Specifications*.
6. Measure for a bent camshaft or excessive camshaft runout using the J 7872.
  - 6.1. Mount the camshaft in a suitable fixture.
  - 6.2. Use the J 7872 in order to measure for a bent camshaft. Refer to *Engine Mechanical Specifications*.
7. Replace the camshaft if runout exceeds specifications.

8. Inspect the camshaft bearings (1-5) for serviceability.
9. Replace the camshaft bearings if necessary. Refer to *Camshaft Bearing Removal* and *Camshaft Bearing Installation*.

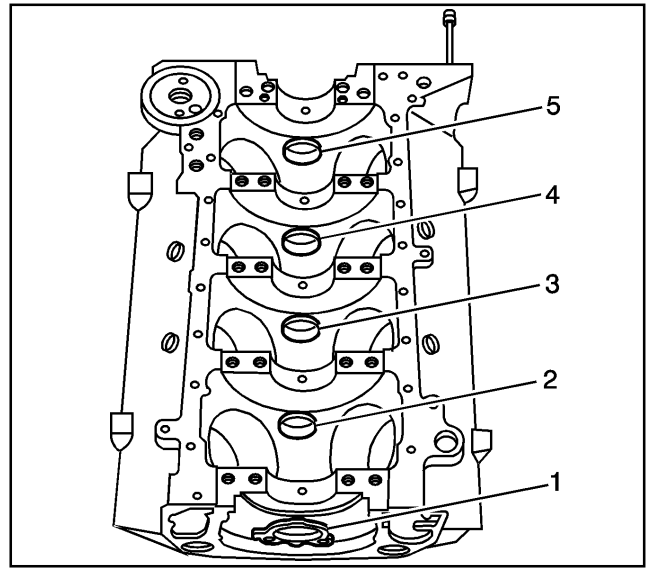

639523

### Camshaft Bearing Installation

#### Tools Required

*J 33049* Camshaft Bearing Remover/Installer

**Important:** The outer camshaft bearings (positions 1 and 5) must be installed first. These bearings serve as guides for the tool and help center the inner bearings during the installation process.

Ensure the correct camshaft bearing fits into the proper bore. The camshaft bearing bores may vary in size.

Ensure that the camshaft bearing lubrication hole or holes align with the oil gallery hole or holes in the block. On some engines, the oil holes may be difficult to see. Verify that the holes are aligned.

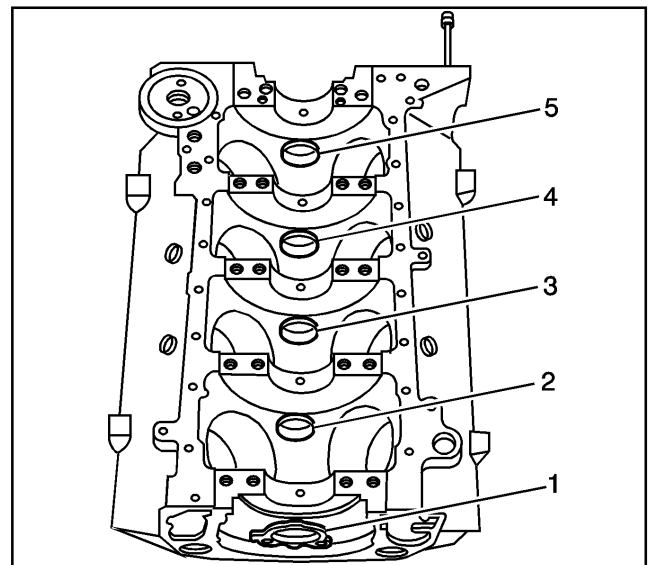

639523

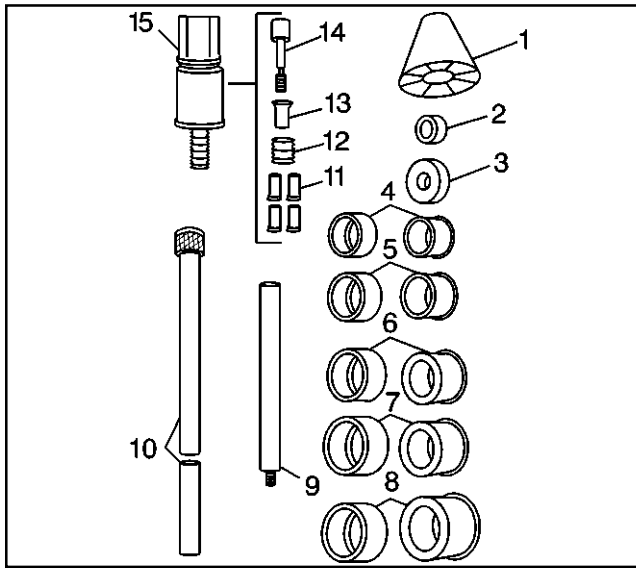

66100

1. Assemble the tool handle (10), expanding driver (4-8) and washer (2 or 3).

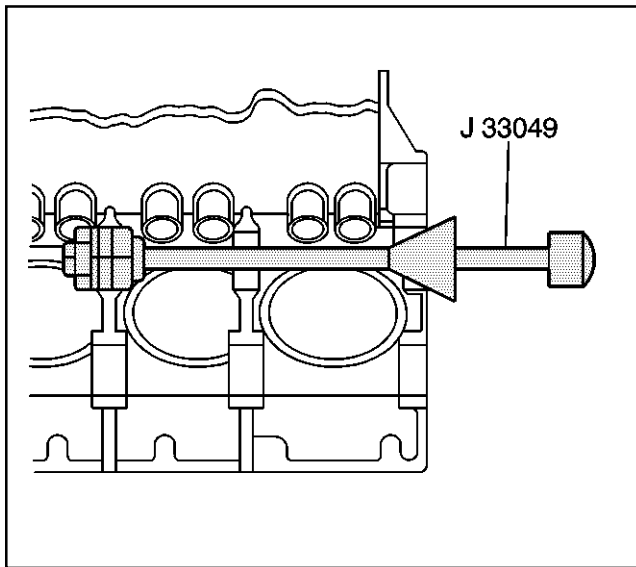

4985

2. Insert the J 33049 tool into the engine block end camshaft bearings (positions 1 or 5).
- Notice:** Do not shim, scrape or file bearing inserts. Do not touch the bearing surface of the insert with bare fingers. Skin oil and acids will etch the bearing surface.

**Important:** The camshaft bearing oil holes must align with the oil galleries in the engine block.

After installation of the camshaft bearings, inspect the camshaft bearing oil holes for proper alignment with the oil galleries.

An improperly aligned camshaft bearing oil gallery hole will restrict oil flow to the bearing and the camshaft journal.

3. Drive the end bearings (positions 1 and 5) into the bore.

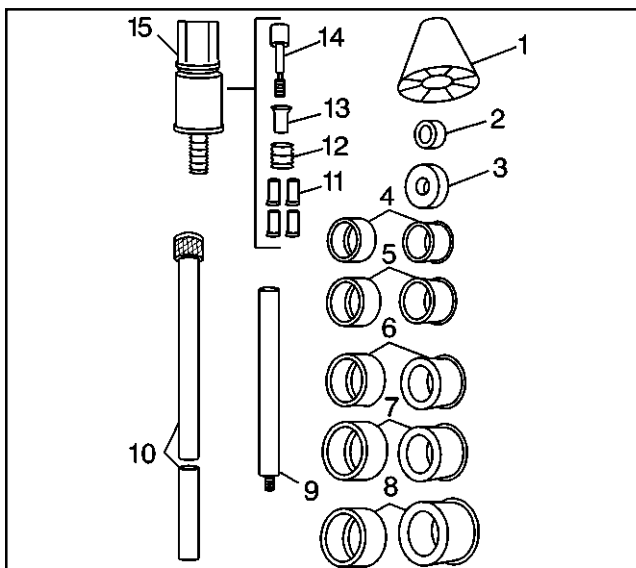

66100

4. Select the expanding driver (4-8) and washer (2 or 3) from the J 33049.
5. Assemble the tool.

6. Insert the J 33049 tool through the front of the engine block and to the inner bearing bores (positions 2-4).
7. Install the bearing onto the expanding driver (4-8).
8. Tighten the expander assembly nut (15) until the tool is snug in the bearing.

**Important:** The camshaft bearing oil holes must align with the oil galleries in the engine block.

After installation of the camshaft bearings, inspect the camshaft bearing oil holes for proper alignment with the oil galleries.

An improperly aligned camshaft bearing oil gallery hole will restrict oil flow to the bearing and the camshaft journal.

9. Align the oil lubrication hole in the bearing with the oil galleries in the engine block.
10. Push the guide cone (1) into the front camshaft bearing bore to align the tool.
11. Drive the bearing into the bore.

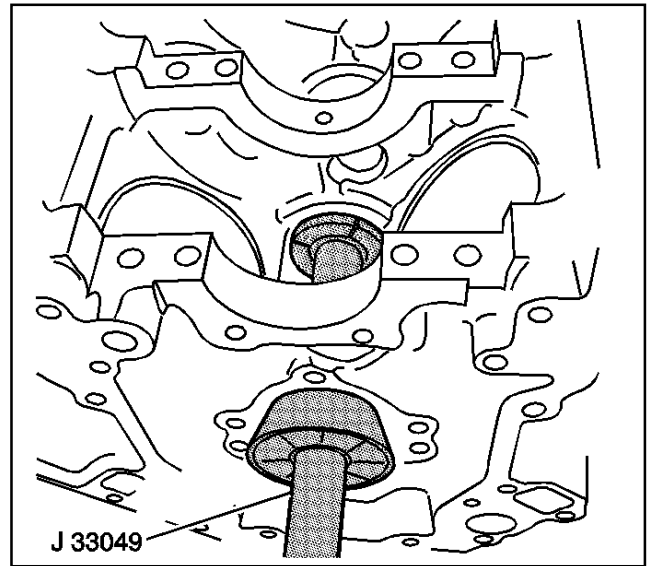

64183

### Timing Chain and Sprockets Clean and Inspect

1. Clean the camshaft timing components in solvent.

**Caution:** *Wear safety glasses in order to avoid eye damage.*

2. Dry the components with compressed air.
3. Inspect the camshaft timing chain for binding or wear.

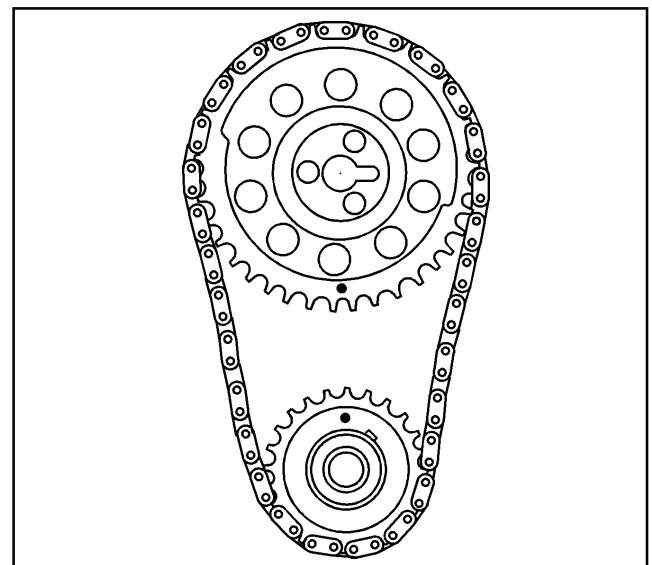

67756

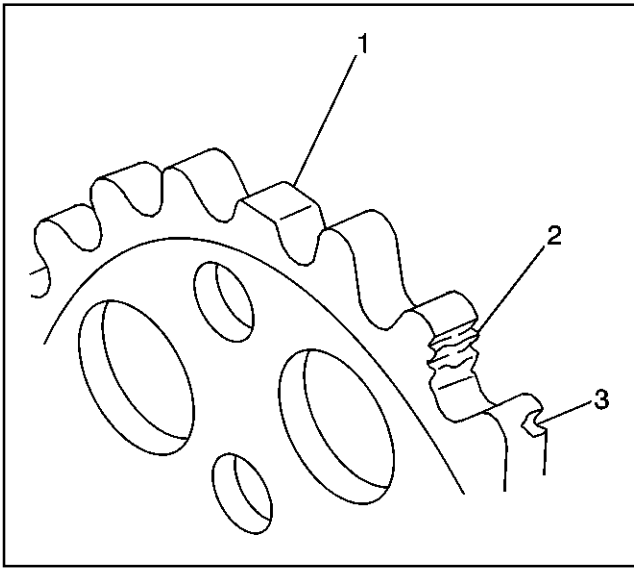

188097

**Important:** If the sprocket(s) must be replaced, replace both sprockets to ensure that timing chain centerline alignment is maintained.

4. Inspect the camshaft and crankshaft sprockets for the following:
  - Worn teeth (1)
  - Damaged teeth (2)
  - Chipped teeth (3)
  - Uneven wear on one edge of the teeth
  - Worn valleys between the sprocket teeth
  - Crankshaft sprocket keyway for wear

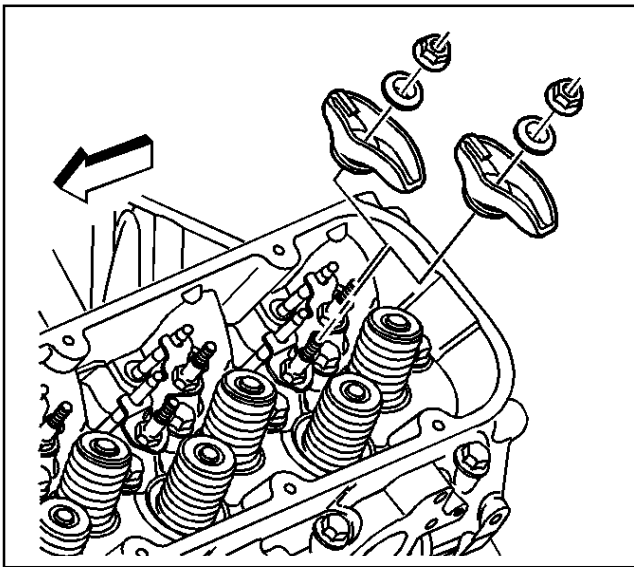

470899

### Valve Rocker Arm and Push Rods Clean and Inspect

**Important:** Parts that are to be reused must remain sorted or organized in order to return to their original locations.

1. Clean the components in solvent.

**Caution:** *Wear safety glasses in order to avoid eye damage.*

2. Dry the components with compressed air.
3. Inspect the valve rocker arms for wear or scoring in the ball area.
4. Inspect the valve rocker arm push rod sockets and valve stem tip mating surfaces.
5. Inspect the valve rocker arm ball for wear or scoring. These surfaces should be smooth with no scoring or exceptional wear.
6. Inspect the push rods for worn or scored ends. These surfaces should be smooth with no scoring or exceptional wear.
7. Inspect the push rods for bends. Roll the push rods on a flat surface to determine if the push rod is bent.
8. Inspect the push rod oil passages for restrictions.
  - Clean out the push rod tube with compressed air.
  - Visually look through the push rod tube for obstructions, a clear push rod will allow light through.
  - Replace push rod(s) that cannot be cleaned out.

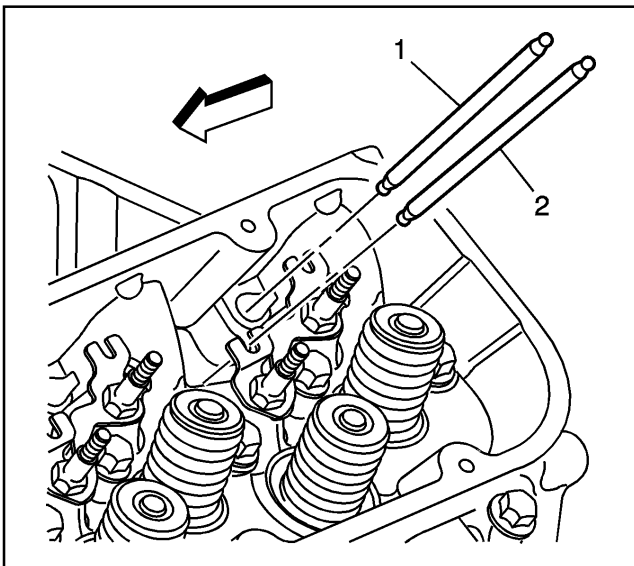

470903

**Important:** A light contact mark on the rocker arm stud is normal. A noticeable groove in the rocker arm stud is excessive wear and the rocker arm stud should be replaced.

9. Inspect the rocker arm studs for the following:
  - Damaged threads (1)
  - Wear or damage made from contact between the rocker arm and rocker arm stud (2)
10. Valve rocker arm studs with excessive wear and/or damage must be replaced.

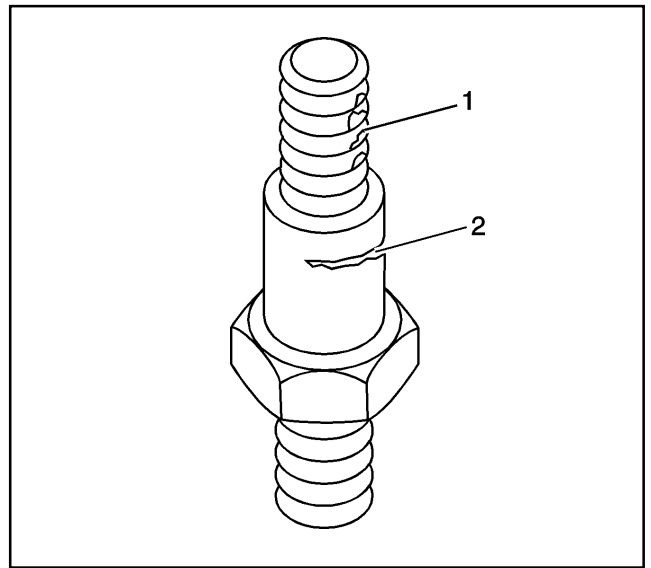

635671

11. Inspect the push rod guides for the following:
  - Wear between the push rod and the push rod guide (1)
  - Bent push rod guide (2)
  - Cracks
12. Push rod guides with excessive wear and/or damage must be replaced.

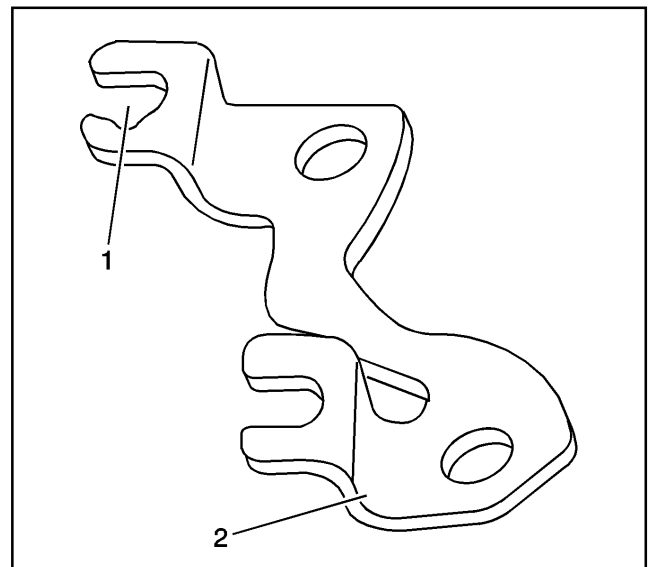

635675

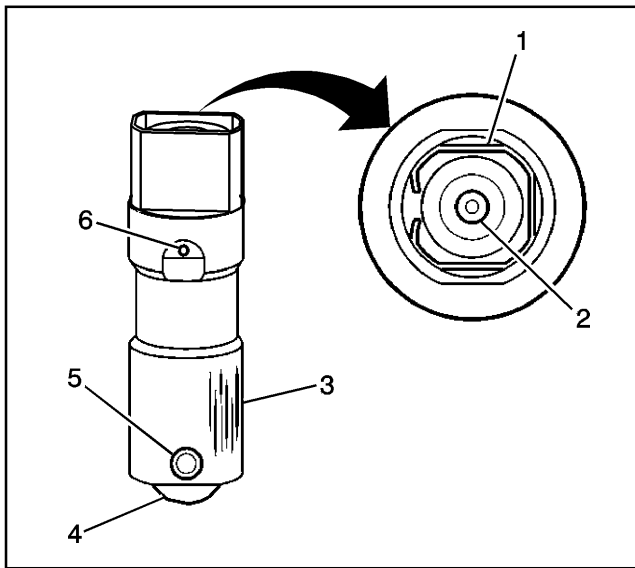

677752

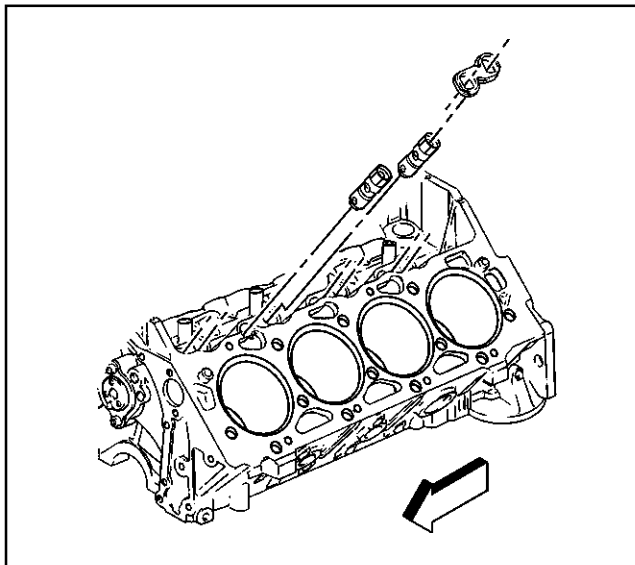

173176

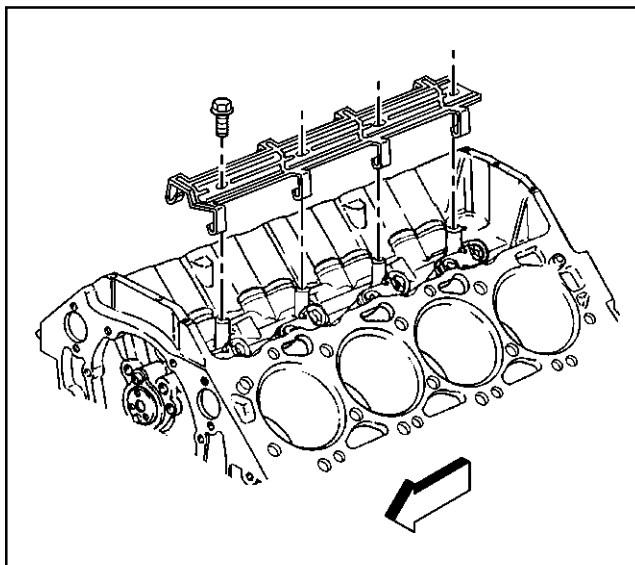

173193

## Valve Lifters and Guides Clean and Inspect

**Important:** Parts that are to be reused must remain sorted or organized in order to return them to their original locations.

**Important:** Disassembly of the valve lifter(s) is not recommended.

1. Clean the components in solvent.

**Caution:** *Wear safety glasses in order to avoid eye damage.*

2. Dry the components with compressed air.
3. Inspect the valve lifters for the following:
  - A damaged, mispositioned or broken clip (1)
  - A scored or worn pushrod socket (2)
  - A severely scuffed or worn lifter body (3)

If the valve lifter body shows scuffing or wear, inspect the engine block valve lifter bores for wear or damage.

- Flat spots on the roller (4)
  - A loose pin (5)
  - A plugged oil hole (6)
4. If flat spots are found on the lifter(s), inspect the corresponding lobe on the camshaft for damage.
  5. Inspect the valve lifter guides for the following:
    - Excessive guide slot side wear
    - Cracks or damage

6. Inspect the valve lifter guide retainer for the following:
  - Wear, damage or stress cracking in the leg areas
  - Wear or damage around the retainer bolt holes



### Cylinder Head Disassemble

#### Tools Required

J 8062 Valve Spring Compressor

**Caution:** Wear safety glasses in order to avoid eye damage.

**Caution:** Compressed valve springs have high tension against the valve spring compressor. Valve springs that are not properly compressed by or released from the valve spring compressor can be ejected from the valve spring compressor with intense force. Use care when compressing or releasing the valve spring with the valve spring compressor and when removing or installing the valve stem keys. Failing to use care may cause personal injury.

**Important:** Mark, sort or organize components for return to their original locations.

1. Use the J 8062 in order to compress the valve springs.

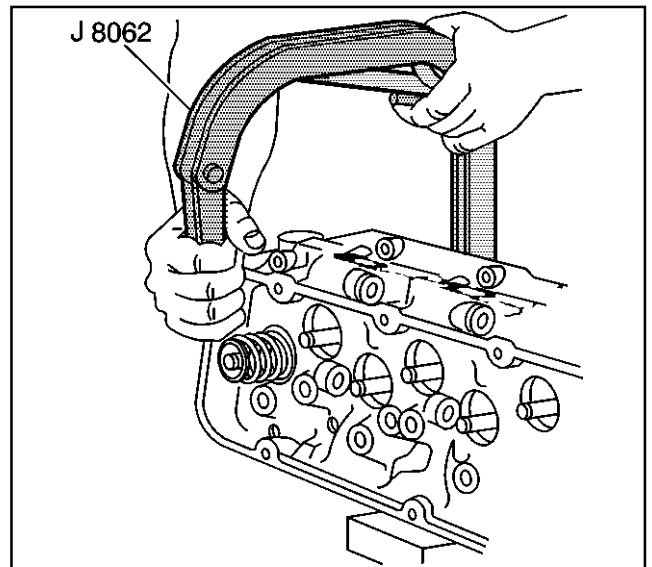

196664

2. Remove the valve stem keys (1).
3. Release and remove the J 8062.
4. Remove the cap (2).
5. Remove the valve spring (3).
6. Remove the positive valve stem seal (4) from the valve guide.
7. Remove the valve rotator (5).

**Important:** In order to prevent damage to the valve guide, small burrs on the valve tip and at the stem key groove that interfere with the valve removal can be lightly filed with a fine file or stone to facilitate valve removal.

8. Remove the valve (6).

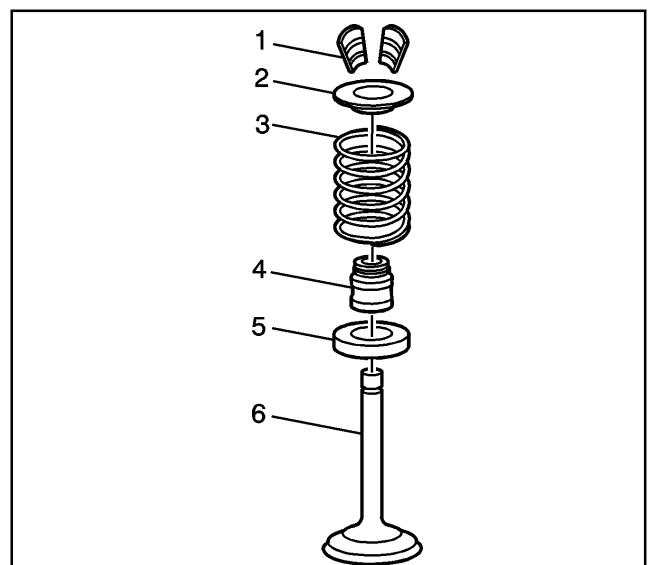

677748

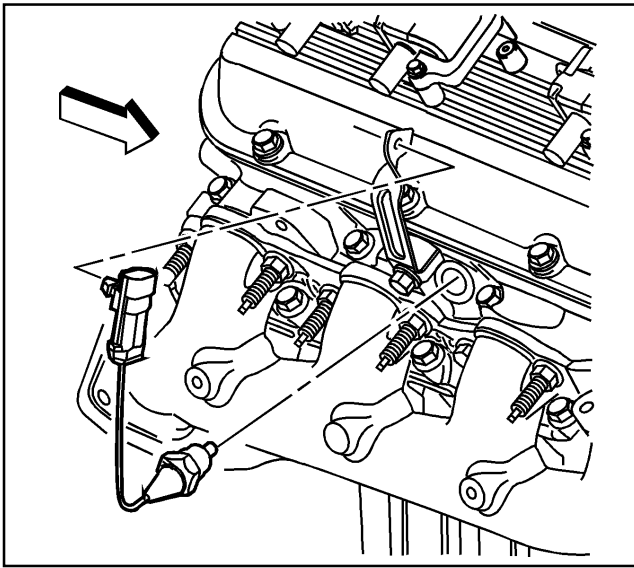

470744

9. Disconnect the Engine Coolant Temperature (ECT) sensor from the bracket.
10. Remove the ECT sensor from the right cylinder head.
11. Remove the ECT sensor bracket and bolt.

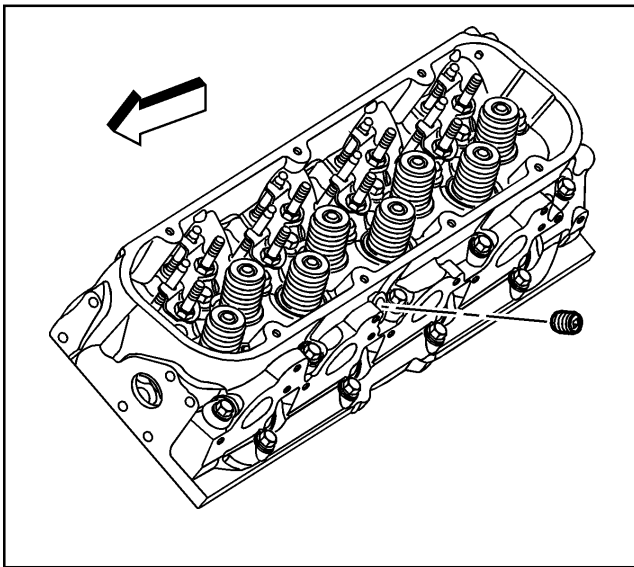

635678

12. Remove the cylinder head coolant plug from the left cylinder head.

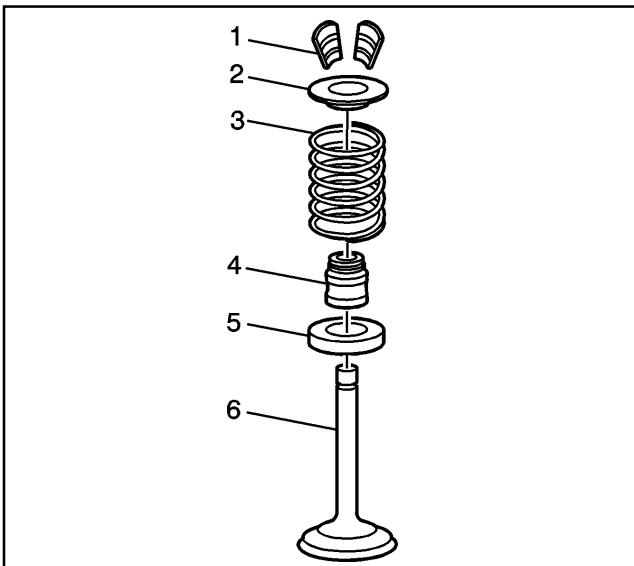

677748

### Cylinder Head Clean and Inspect

#### Cleaning Procedure

#### Tools Required

*J 8089* Carbon Removing Brush

**Caution:** *Wear safety glasses in order to avoid eye damage.*

**Important:** Mark, sort or organize components for return to their original locations.

1. Clean the valve stems and heads on a buffing wheel.
2. Clean the following components in solvent:
  - Valve stem keys (1)
  - Valve spring cap (2)
  - Valve spring (3)
  - Valve rotators (5)
  - Valve (6)
  - Cylinder head

**Caution:** Wear safety glasses in order to avoid eye damage.

3. Dry the components with compressed air.

**Important:** Be careful not to damage the chamber or the valve seat.

4. Use the J 8089 in order to clean the carbon from the combustion chambers.

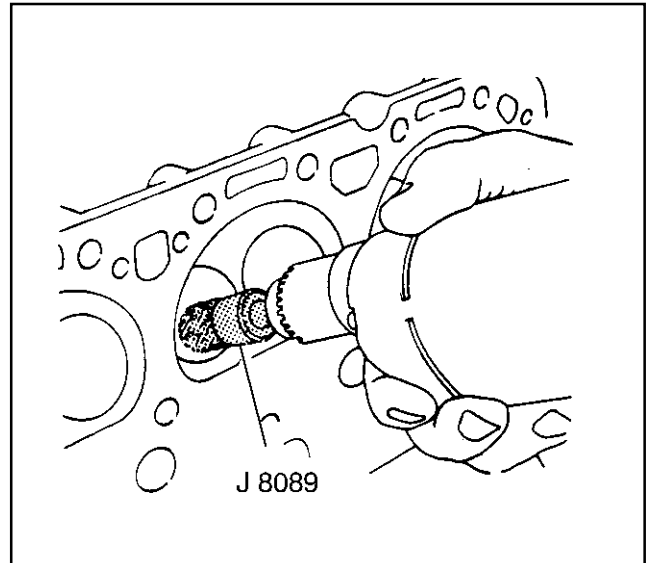

35201

**Visual Inspection Procedure**

Inspect the cylinder head for the following:

- Damaged gasket surfaces
- Damage to threaded bolt holes
- Burnt or eroded areas in the combustion chamber
- Cracks in the exhaust ports and combustion chambers
- External cracks in the water chamber
- Restrictions in the intake or exhaust passages
- Restrictions in the cooling system passages

**Flatness Measurement Procedure**

1. Measure the cylinder head for warpage with a straight edge and feeler gauge.
  - A cylinder head block deck with warpage in excess of 0.050 mm (0.002 in) within a 150.0 mm (6.0 in) area must be repaired or replaced.
  - A cylinder head exhaust manifold deck with an overall warpage in excess of 0.102 mm (0.004 in) must be repaired or replaced.
  - A cylinder head intake manifold deck with warpage in excess of 0.080 mm (0.003 in) must be repaired or replaced.
2. A cylinder head block deck can be resurfaced up to 0.305 mm (0.012 in) maximum removal.

**Important:** Excessive cylinder head resurfacing will affect compression ratio and emission control.

3. A cylinder head that requires excessive resurfacing must be replaced.

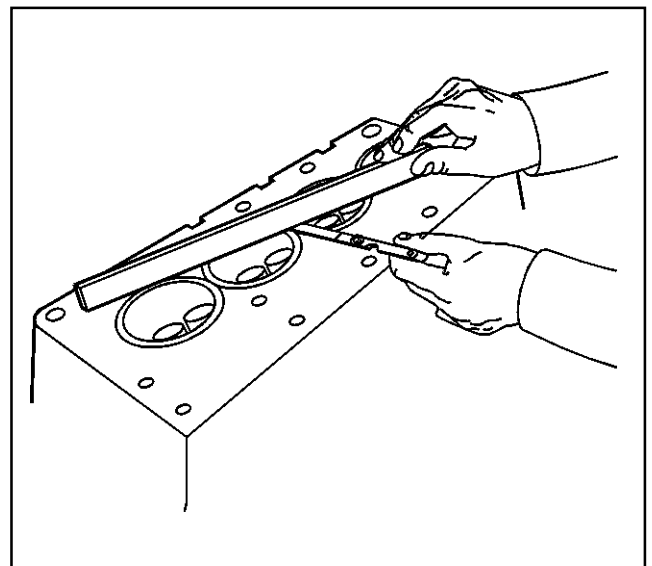

64318

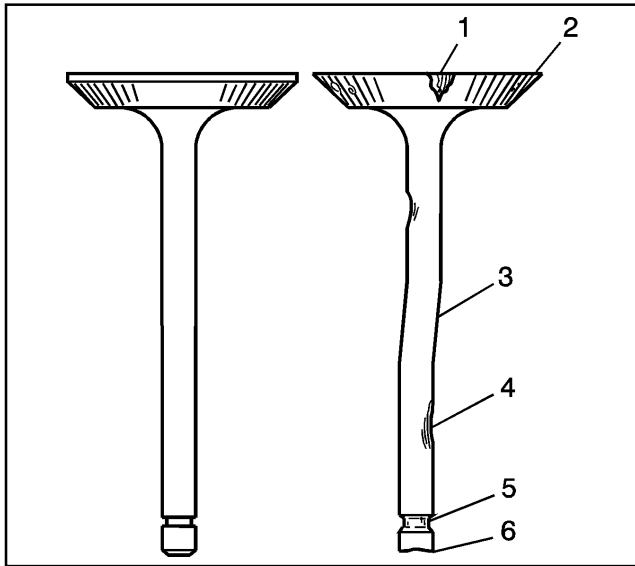

677854

### Valve Inspection Procedure

1. Inspect the valves for the following:
  - Burnt or damaged areas (1)
  - Undersized valve margin (2)
  - Bent stem (3)
  - Scoring or other damage to the stem (4)
  - Worn key groove (5)
  - Worn stem tip (6)

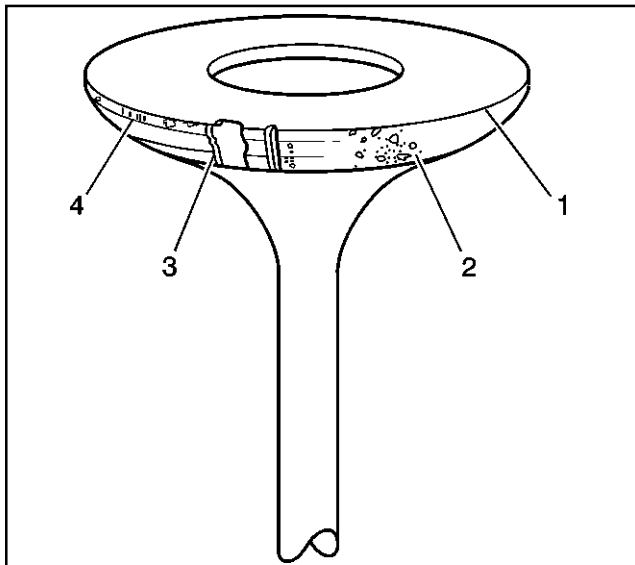

156173

2. Inspect the valve contact surface for the following:
  - Undersized margin (1)
  - Pitted surface (2)
  - Burnt or eroded areas (3)
  - Acceptable edge (margin) (4)

**Important:** Minor imperfections of the valve may be corrected during reconditioning.

3. Valves with excessive damage must be replaced.

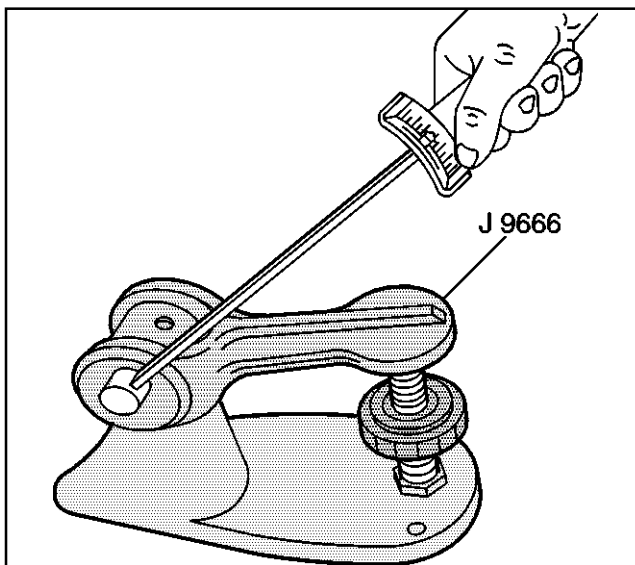

4960

### Valve Spring Inspection and Measurement

#### Tools Required

J 9666 Valve Spring Tester

1. Inspect the valve springs for broken coils or coil ends.
2. Use the J 9666 in order to measure the valve spring force. Refer to *Engine Mechanical Specifications*.

**Important:** Add a maximum of one shim up to 0.726 mm (0.030 in) thick to increase tension.

3. If the valve spring tension is low, use a shim to increase tension.
4. Recheck the valve spring tension, a valve spring that does not meet specifications must be replaced.

### Valve Guide Measurement Procedure

#### Tools Required

J 8001 Dial Indicator Set

**Important:** Excessive valve stem-to-guide clearance may cause excessive oil consumption and may also cause a valve to break. Insufficient clearance will result in noisy and sticky functioning of the valve and will disturb the engine assembly smoothness.

1. Measure the valve stem-to-guide clearance.
  - 1.1. Clamp the J 8001 on the exhaust port side of the cylinder head.

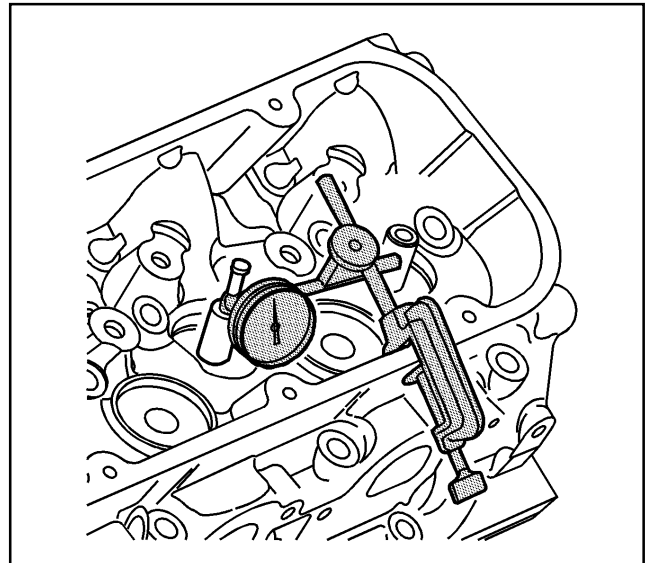

677797

**Important:** The indicator stem must contact the side of the valve stem just above the valve guide.

- 1.2. Locate the indicator so that the movement of the valve stem from side to side (crosswise to the cylinder head) will cause a direct movement of the indicator stem.
- 1.3. Drop the valve head about 1.6 mm (0.064 in) off the valve seat.
- 1.4. Use light pressure when moving the valve stem from side to side in order to obtain a clearance reading. Refer to *Engine Mechanical Specifications*.
2. Valve guide (2) with excessive clearance must be repaired. Refer to *Valve Guide Reaming/Valve and Seat Grinding*.
3. Replace the cylinder head if the valve guide cannot be repaired or reamed to accept an oversize valve stem.

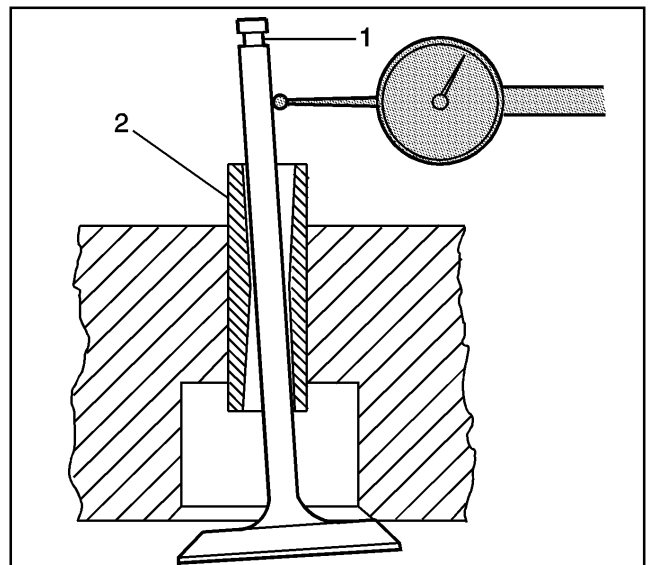

719136

### Valve Guide Reaming/Valve and Seat Grinding

#### Valve Guide Reaming Procedure for Oversized Valve Stems

1. Ream the valve guide as necessary to achieve proper valve stem-to-guide clearance with the new, oversized valve stems.
2. Always recondition the valve seat after reaming the valve guide bores or installing new valves.
3. Replace the cylinder head if the valve guide cannot be repaired or reamed to accept an oversize valve stem.

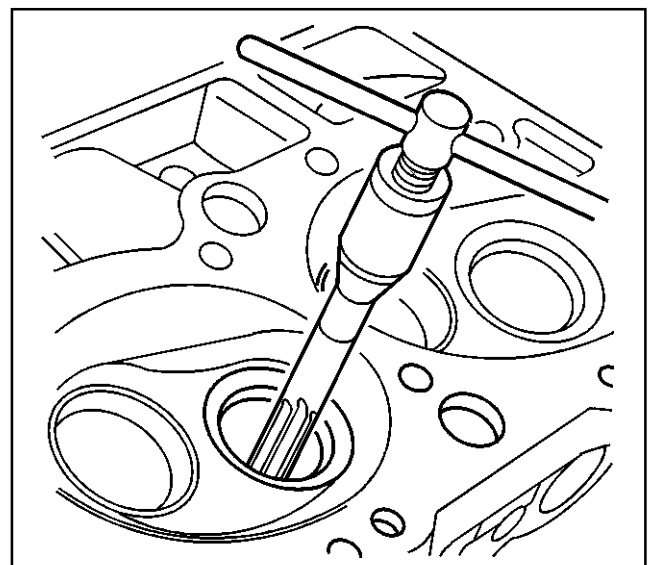

4956

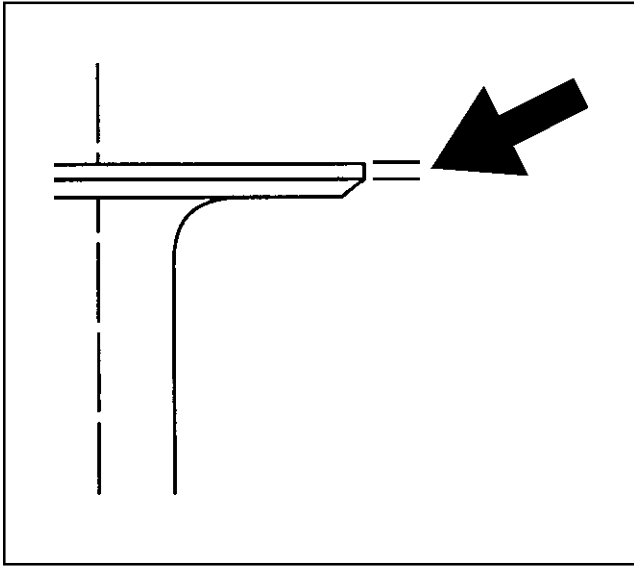

57502

### Valve Reconditioning Procedure

1. Replace the valve if the valve stem shows excessive wear or is warped.

**Important:** Several different types of equipment are available for reconditioning valves. Use the manufacturer's recommendations of equipment to attain proper results.

2. Reface pitted valves on a valve refacing machine in order to ensure the correct relationship between the head and the valve stem.
3. Replace the valve if the edge of the head is less than 0.79 mm (0.031 in) thick after grinding.

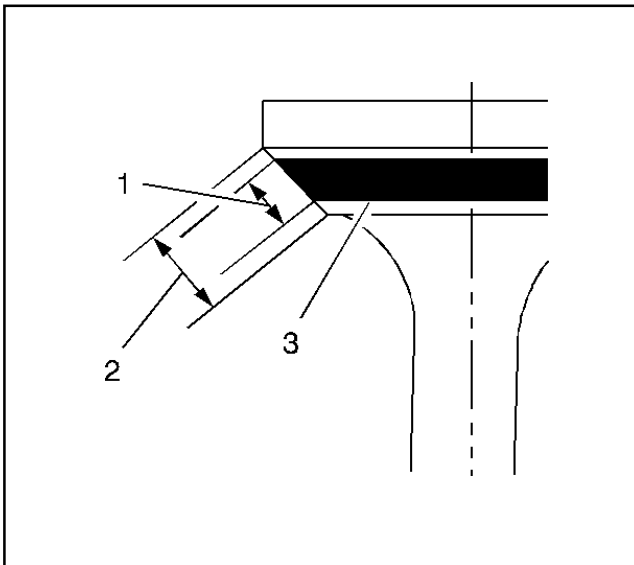

53234

### Valve Seat Reconditioning Procedure

**Important:** Several different types of equipment are available for reconditioning valve seats. Use the manufacturer's recommendations of equipment to attain proper results.

**Important:** Always recondition the valve seat after reaming the valve guide bores or installing new valves.

1. Recondition the valve seats.
2. The valves must seat perfectly for the engine to deliver optimum power and performance.
3. Ensure that the valve seat and the valve are not shrouded after the valve seat reconditioning. Adequate flow past the valve seat and valve is essential for cooling the valve head and valve seat area.

4. Correct contact (1) between each valve and its seat in the cylinder head is also essential to ensure that the heat in the valve head is properly carried away.

**Important:** Regardless of what type of equipment is used, it is essential that the valve guide bores are free from carbon or dirt to ensure the proper centering of the pilot in the guide.

5. The valve seats should be concentric to within 0.050 mm (0.002 in) total indicator runout.

### Cylinder Head Assemble

#### Tools Required

J 8062 Valve Spring Compressor

J 43105 Valve Stem Seal Installer

#### Checking Valve Spring Installed Height

1. Install the valve rotator (3), the valve (4), the valve spring cap (1) and the valve stem keys (5) into the cylinder head.
2. Using a snap gauge or inside micrometer, measure the distance from the top of the valve rotator to the bottom of the valve spring cap. Refer to *Engine Mechanical Specifications* for proper valve spring installed height specifications.

#### Important:

- Never shim the spring to obtain an installed height under the specified amount.
  - Install the valve spring seat shims under the rotator (between the rotator and the cylinder head spring seat).
  - Add a maximum of one valve spring seat shim, up to 0.726 mm (0.030 in) thick to achieve the valve spring installed height specification.
  - The combination of valve spring seat shims to correct valve spring installed height and valve spring tension should not exceed 1.524 mm (0.060 in) thick.
3. Install a valve spring seat shim if the valve spring installed height measurement is above the specification.
  4. Recheck the valve spring installed height, replace the cylinder head if the valve spring installed height cannot be obtained.

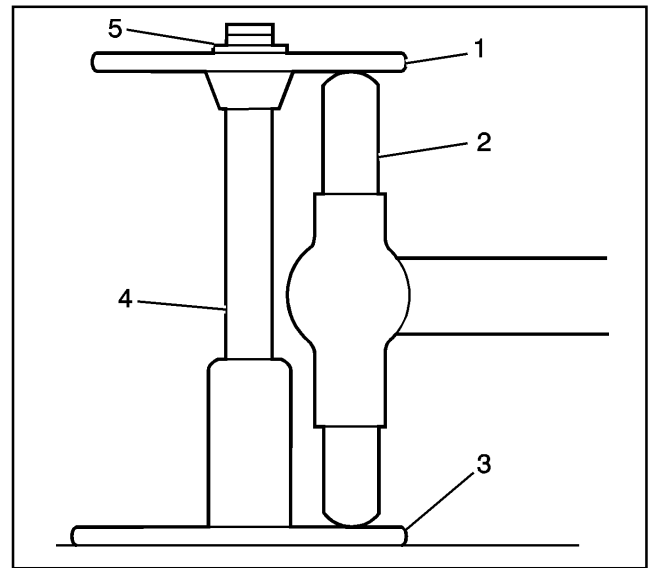

635681

#### Valve Installation

**Caution: Wear safety glasses in order to avoid eye damage.**

**Caution: Compressed valve springs have high tension against the valve spring compressor. Valve springs that are not properly compressed by or released from the valve spring compressor can be ejected from the valve spring compressor with intense force. Use care when compressing or releasing the valve spring with the valve spring compressor and when removing or installing the valve stem keys. Failing to use care may cause personal injury.**

1. Lubricate the valve stems (6) with clean engine oil.
2. Insert the valves into their proper locations.
3. Install the necessary valve spring shims onto the cylinder head.
4. Lubricate the rotators (5) with clean engine oil.
5. Install the rotators over the guide and onto the valve spring shims, if applicable.

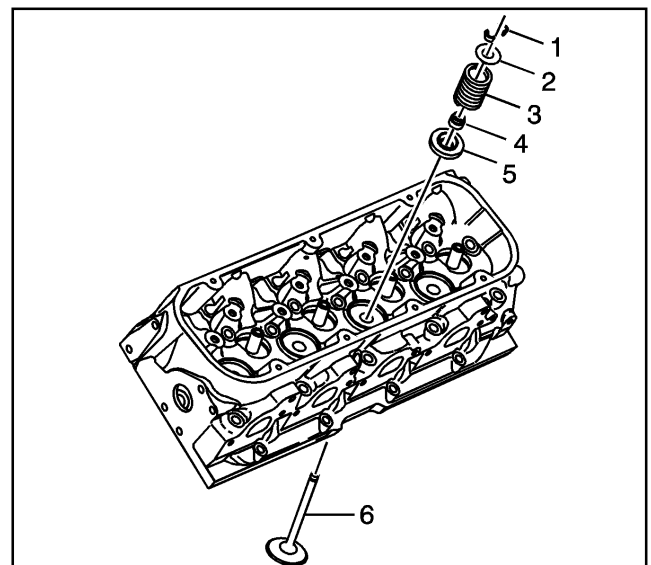

677779

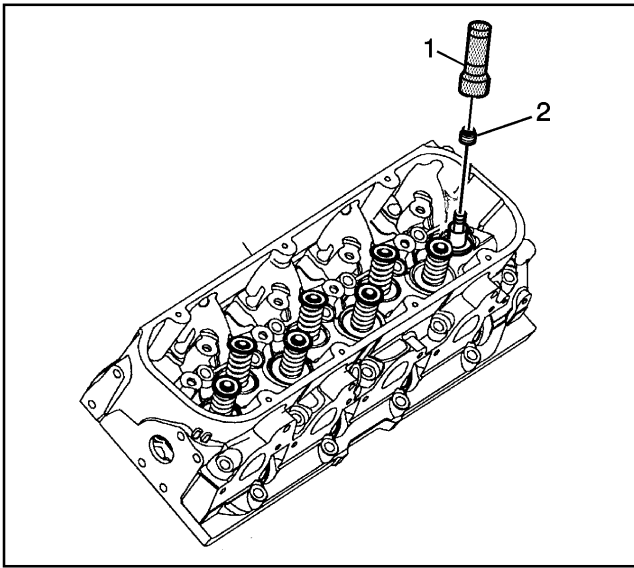

719126

**Important:** When installing valve stem oil seals onto the valve guides, be careful not to tear the seal lip.

**Important:** When installing valve seals, J 43105 must be used to achieve correct installation. Failure to use J43105 may cause excessive oil consumption.

6. Lubricate the valve stem seal and the outside diameter of the valve guide with clean engine oil.
7. Install the valve stem oil seals (2) over the valve tip and onto the valve guides using J 43105. Tap the valve stem seal onto the valve guide until the J 43105 fully seats the seal.

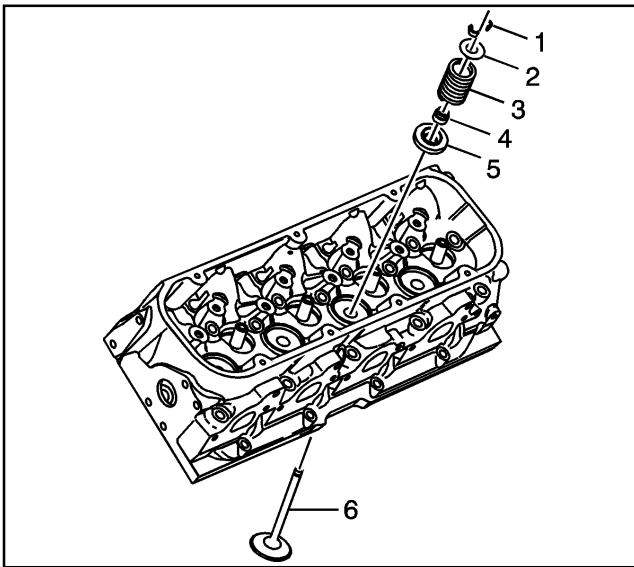

677779

**Important:** When installing valve springs, the small end of the valve spring must be installed up.

8. Install the valve springs (3).
9. Install the valve spring caps (2).

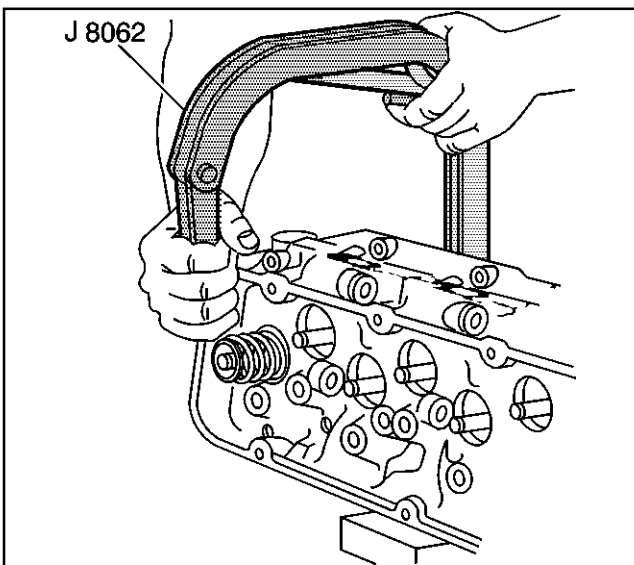

196664

10. Use the J 8062 in order to compress the valve spring. Compress the spring enough to clearly see the valve stem key grooves of the valve.

11. Install the valve stem keys (1).  
Use grease to hold the keys in place.

Ensure that the keys seat properly in the upper groove of the valve stem.

12. Release and remove the J 8062.

13. Lightly tap the end of the valve stem with a plastic-faced hammer to seat the keys.



**Notice:** Refer to *Fastener Notice* in Cautions and Notices.

14. Install the engine coolant temperature (ECT) sensor into the right cylinder head.

**Tighten**

Tighten the ECT sensor to 20 N·m (15 lb ft).

15. Install the ECT sensor bracket and bolt.

**Tighten**

Tighten the ECT sensor bracket to 50 N·m (37 lb ft).

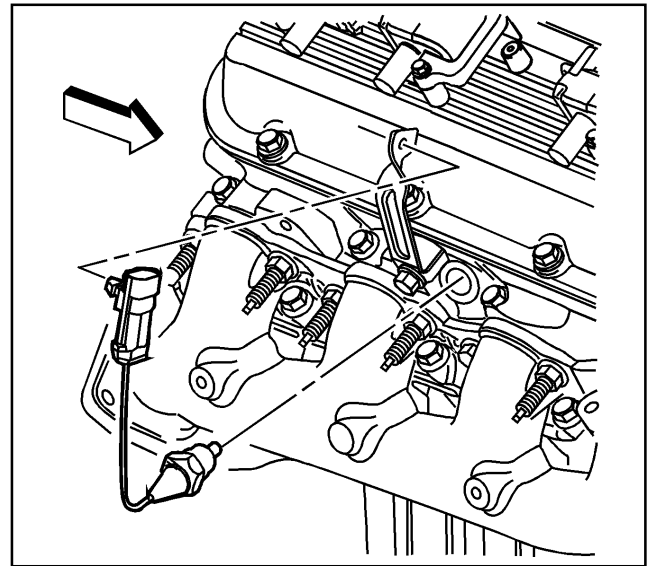

470744

16. Install the cylinder head coolant hole plug (1) into the left cylinder head.

**Tighten**

Tighten the cylinder head coolant hole plug to 23 N·m (17 lb ft).

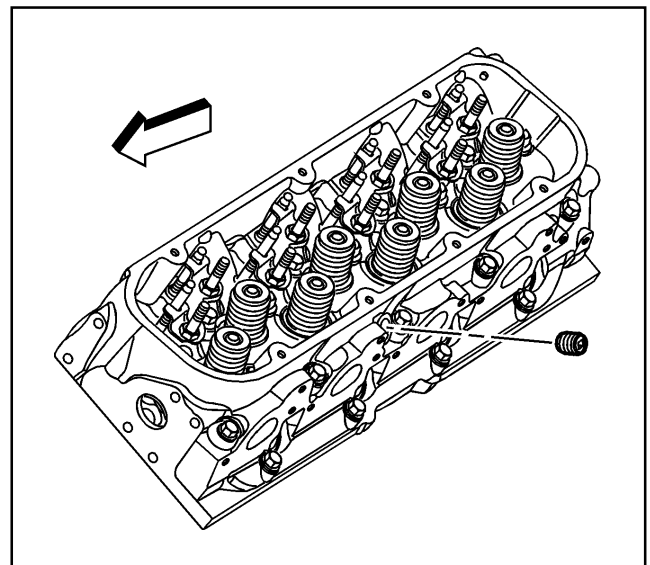

635678

**Oil Pump Disassemble**

**Important:** The oil pump pipe has a press fit into the oil pump. DO NOT remove the pipe from the oil pump. The pipe and oil pump are serviced as a complete assembly.

1. Remove the oil pump driveshaft and retainer.

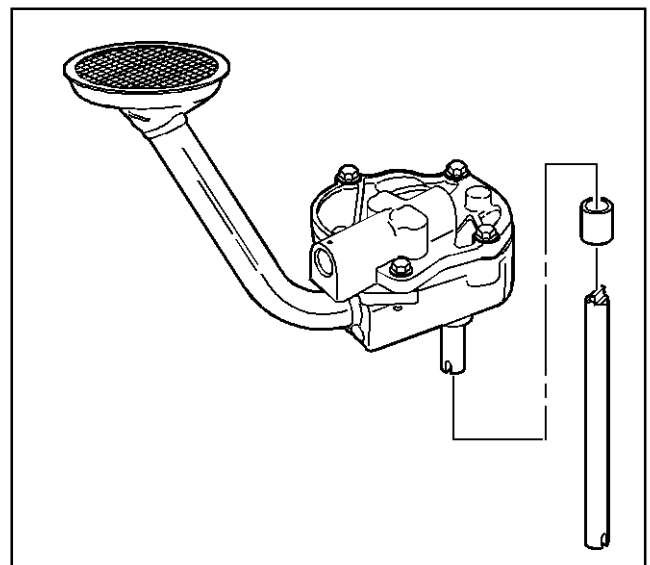

427935

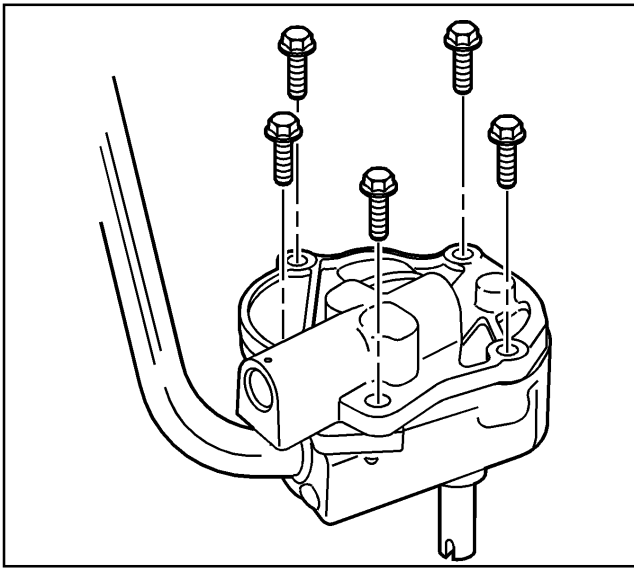

678105

2. Remove the oil pump cover bolts.

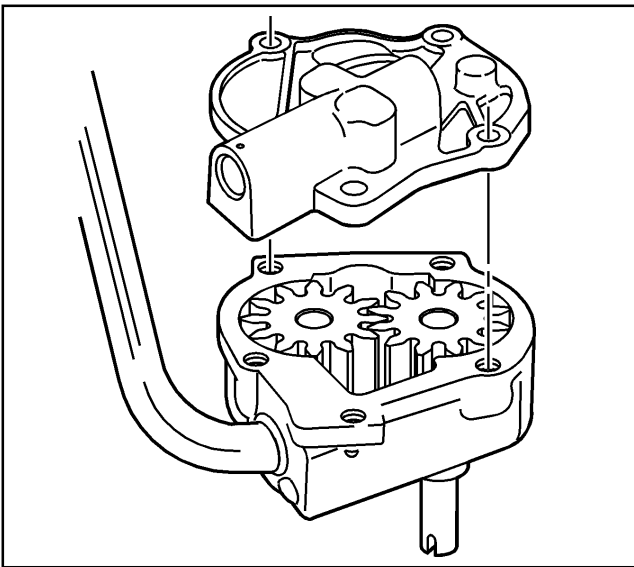

678106

3. Remove the oil pump cover.

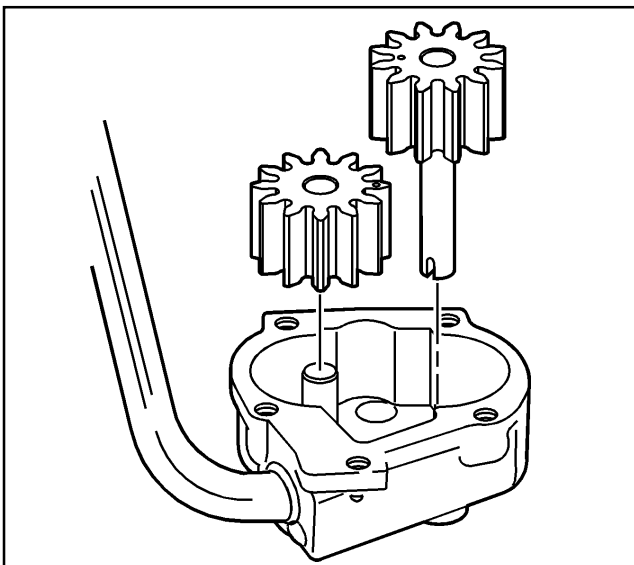

678107

4. Remove the drive gear and the driven gear. Matchmark the gear teeth for assembly.

5. Remove the following items:
  - 5.1. The retaining pin
  - 5.2. The pressure relief spring
  - 5.3. The pressure relief valve

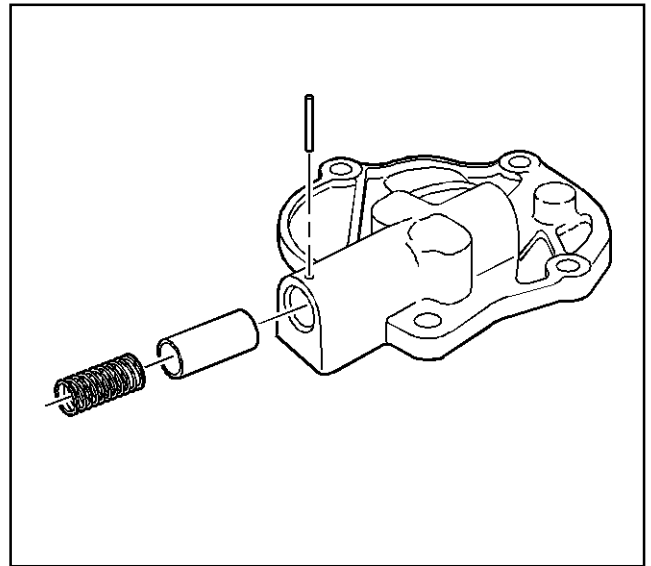

427947

### Oil Pump Clean and Inspect

**Caution:** *Wear safety glasses in order to avoid eye damage.*

1. Clean the oil pump components in cleaning solvent.
2. Dry the components with compressed air.
3. Inspect the oil pump for the following:
  - Scoring on the top of the gears (1)
  - Damaged gears (2) for the following:
    - Chipping
    - Galling
    - Wear
  - Scoring, damage or casting imperfections to the body (3)
  - Damaged or scored gear shaft (4)
  - Damaged or scored gear shaft (5)
  - Damaged bolt hole threads
  - Worn oil pump driveshaft bore
  - Damaged or sticking oil pump pressure relief valve (minor imperfections may be removed with a fine oil stone).
  - Collapsed or broken oil pump pressure relief valve spring.
4. If the oil pump is to be reused, install a NEW oil pump pressure relief valve spring.
5. During oil pump installation, install a NEW oil pump driveshaft retainer.

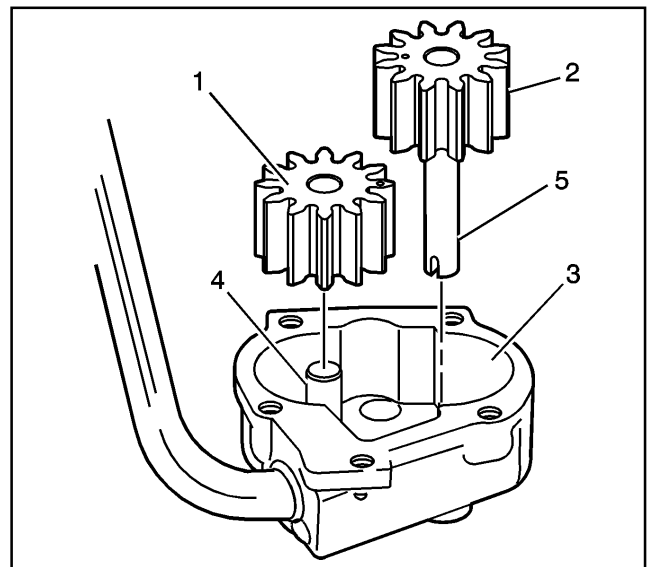

678109

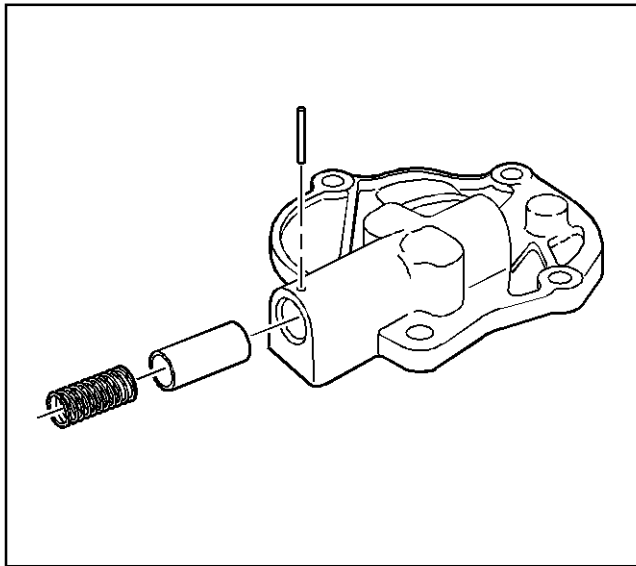

427947

## Oil Pump Assemble

### Tools Required

*J 21882* Oil Suction Pipe Installer

**Important:** Replace the pressure relief valve spring when reusing the oil pump.

1. Install the following items:
  - 1.1. The pressure relief valve
  - 1.2. The pressure relief spring
  - 1.3. The retaining pin
  
2. Coat the drive gear, the driven gear and the housing gear surfaces with clean engine oil.
  
3. Install the drive gear and the driven gear into the pump body. Align the matching marks on the gears. Install the smooth side of the gear toward the pump cover.
  
4. Install the oil pump cover.

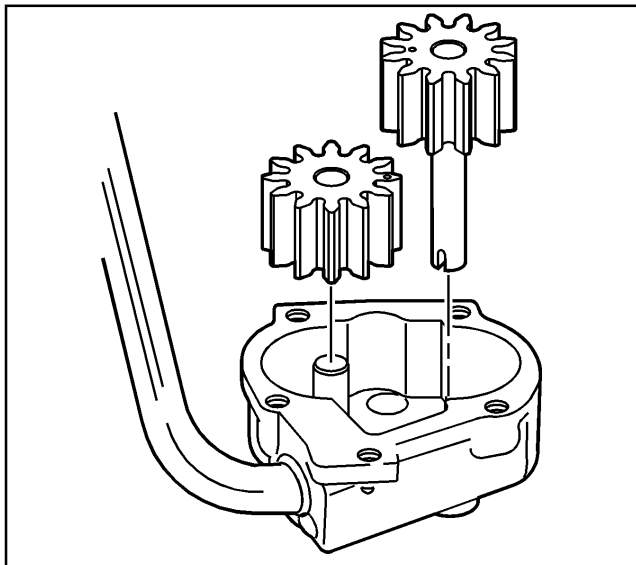

678107

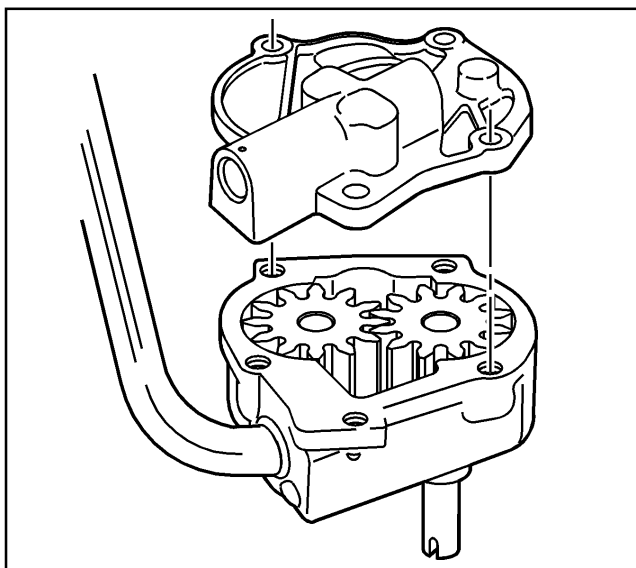

678106

**Notice:** Refer to *Fastener Notice* in Cautions and Notices.

5. Install the oil pump cover bolts.

**Tighten**

Tighten the oil pump cover bolts to 12 N·m (106 lb in).

6. Inspect the oil pump for smoothness of operation by turning the oil pump driveshaft by hand.

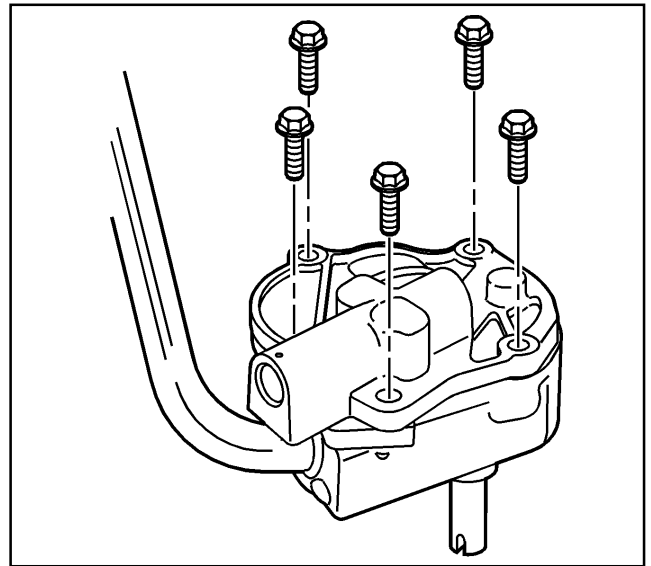

678105

**Important:** Inspect the oil pump driveshaft. An excessively worn or damaged oil pump driveshaft may fail, causing severe engine damage.

7. Install the oil pump driveshaft and the new retainer.

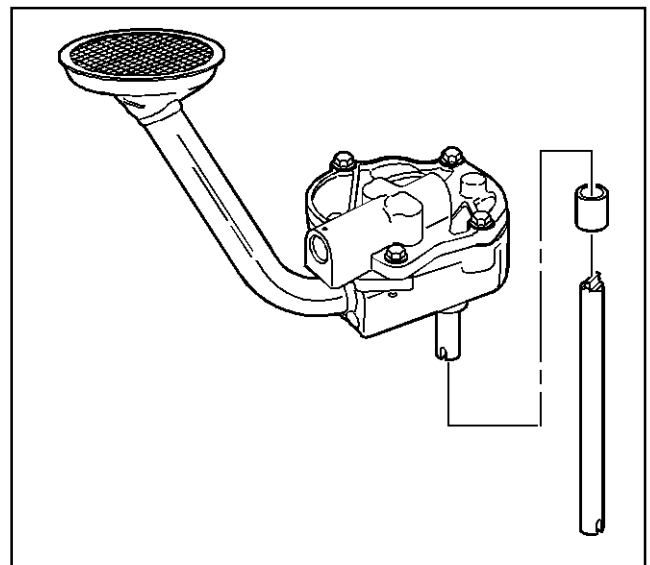

427935

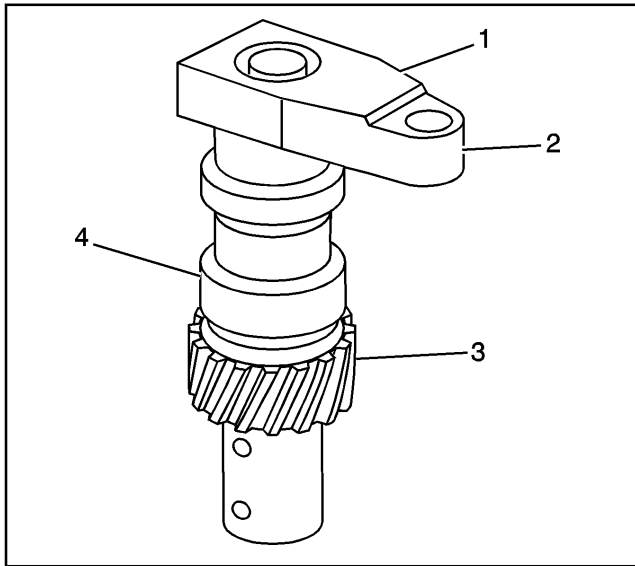

635685

### Oil Pump Drive Clean and Inspect

**Caution:** Wear safety glasses in order to avoid eye damage.

1. Clean the oil pump drive in cleaning solvent.
2. Dry the oil pump drive with compressed air.
3. Inspect the oil pump drive for the following:
  - Excessive play in the oil pump drive bearing (1)
  - Damage to the oil pump drive clamp bolt hole (2)
  - Damaged gear (3) for the following:
    - Chipping
    - Galling
    - Wear
    - Damage to the oil pump drive shaft tang
4. Damage to the oil pump drive body (4).
5. If the oil pump drive is to be reused, lubricate the bearing (1) with clean engine oil.

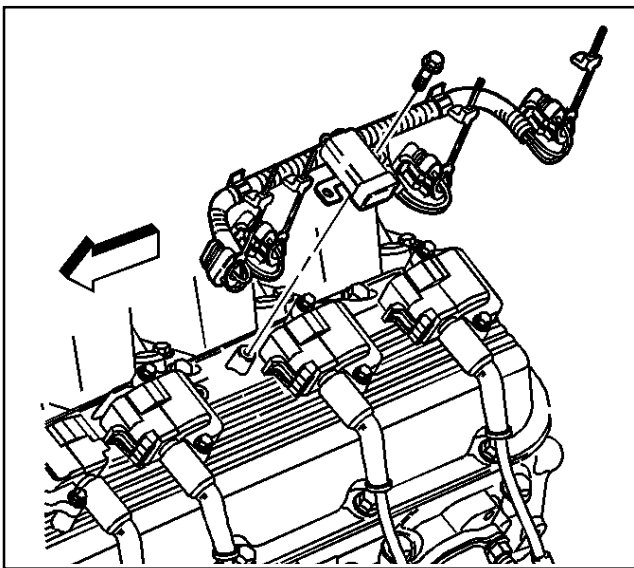

470659

### Valve Rocker Arm Cover Clean and Inspect

**Important:** The ignition wiring harness connectors for cylinders one and three, and cylinders six and eight must be marked when removed to ensure the connectors are reinstalled to the correct ignition coil. Failure to reinstall the connectors to the correct ignition coil may result in serious engine damage.

**Important:** The ignition coil and wiring harness bolts are self-tapping, and care should be taken when removing the bolts. Failure to carefully remove the bolts may damage the valve rocker arm covers, requiring the valve rocker arm covers to be replaced.

1. Remove the white wiring harness clip locks.
2. Disconnect the ignition coil wiring harness from the ignition coils.
3. Remove the ignition coil wiring harness retainer bolts.
4. Open the two wiring harness retainers and remove the ignition coil wiring harness.

5. Remove the ignition coil bolts.
6. Remove the ignition coils.

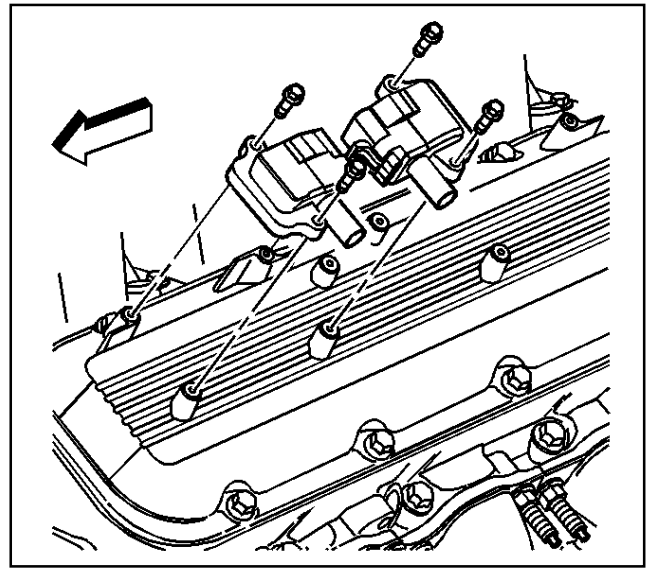

470887

**Caution:** Wear safety glasses in order to avoid eye damage.

**Important:** Do not clean or submerge the ignition coils in solvent.

Remove the ignition coils before cleaning the cover in solvent. To prevent damage to the gasket, minimize solvent contact with the gaskets.

7. Clean the valve rocker arm covers in solvent.
8. Dry the covers with compressed air.
9. Inspect the covers for the following:
  - Gouges or damage to the sealing surfaces
  - Cracking or damage to the valve cover gasket
  - Debris or damage to the bolt hole threads

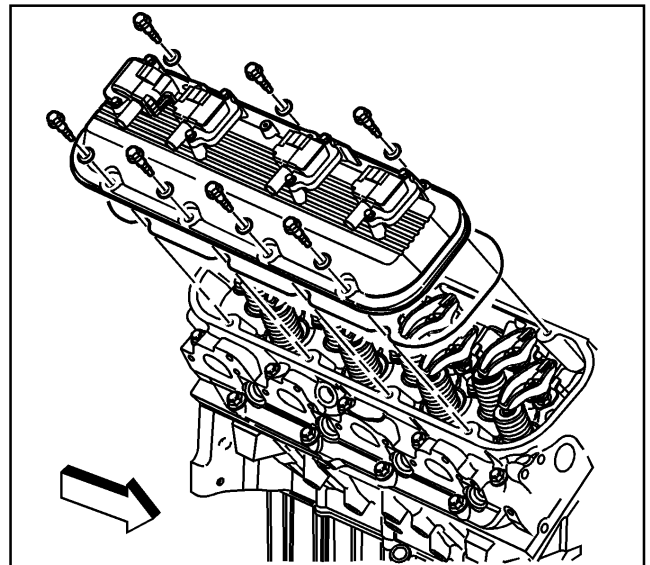

470897

**Notice:** This bolt is a self-tapping bolt. If installing this bolt into a new component, installation of the bolt may be difficult. Ensure that the bolt is not over-torqued during the initial installation (thread cutting). Failure to limit torque can lead to bolt failure.

10. Install the ignition coils.
11. Install the ignition coil bolts.

**Tighten**

Tighten the ignition coil bolts to 12 N·m (106 lb in).

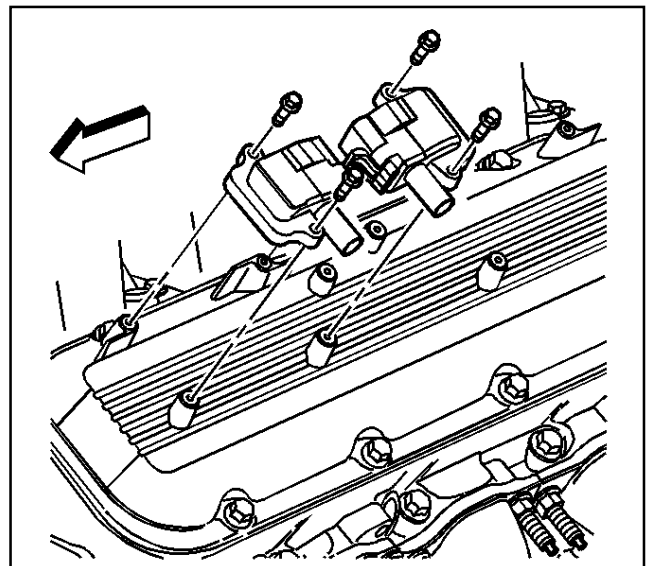

470887

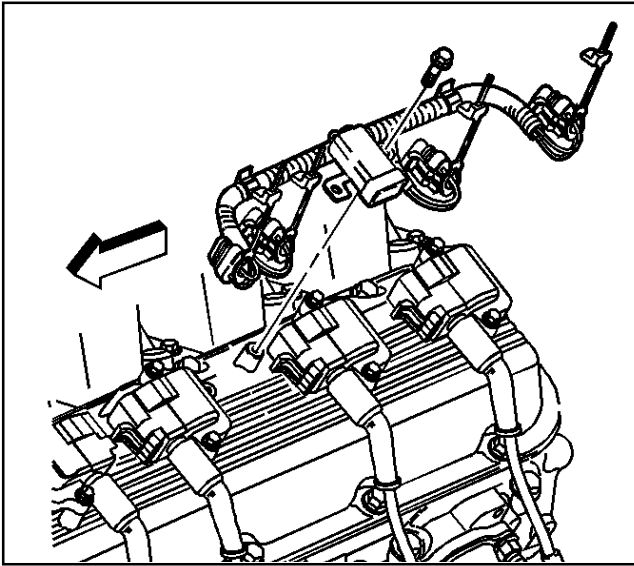

470659

12. Install and secure the ignition coil wiring harness into the two wiring harness retainers.
13. Install the ignition coil wiring harness retainer bolts.  
**Tighten**  
Tighten the ignition coil wiring harness retainer bolts to 12 N·m (106 lb in).
14. Connect the ignition coil wiring harness to the ignition coils, making sure the connectors for cylinders one and three, and cylinders six and eight are connected to the corresponding ignition coils.
15. Install the white wiring harness clip locks.

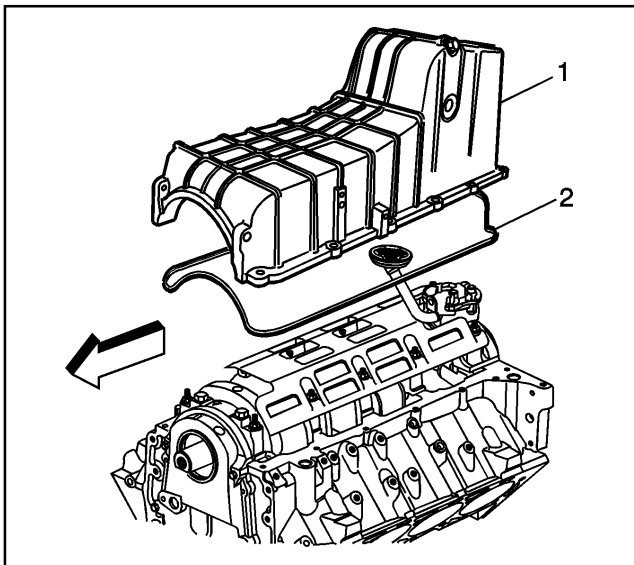

635649

### Oil Pan Clean and Inspect

1. Remove the oil pan gasket from the groove in the oil pan.
2. Clean the oil pan in solvent.

**Caution: Wear safety glasses in order to avoid eye damage.**

3. Dry the oil pan with compressed air.
4. Inspect the oil pan for the following:
  - The drain plug hole for damaged threads.
  - Gouges or damage to the oil pan sealing surface.
  - Cracks or damage to the exterior of the oil pan.
  - Damage to the oil level indicator tube area.
  - Damage to the oil pan gasket.

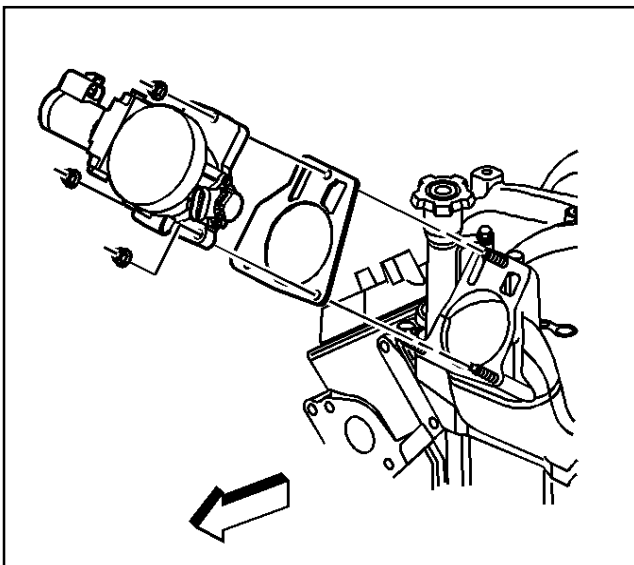

470760

### Intake Manifold Disassemble

1. Remove the throttle body nuts and the throttle body.
2. Remove and discard the throttle body gasket.



3. Remove the MAP sensor bolt and MAP sensor.
4. Inspect the MAP sensor seal for damage.

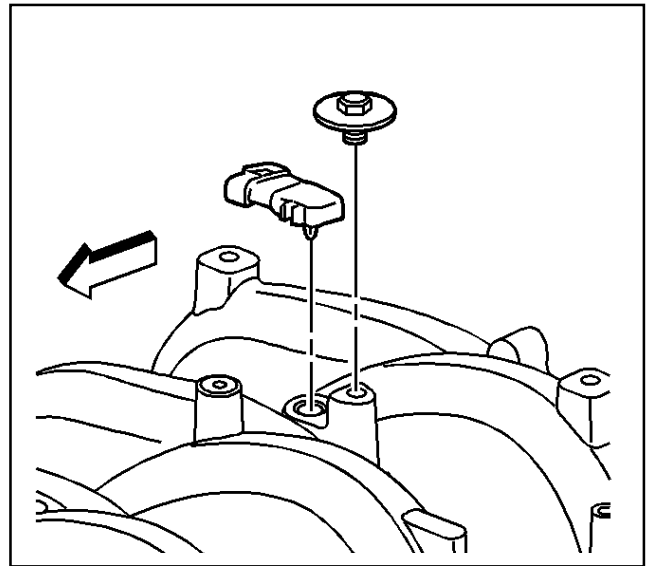

471023

5. Remove the EGR valve bolts, EGR valve and EGR valve gasket.
6. Discard the EGR valve gasket.

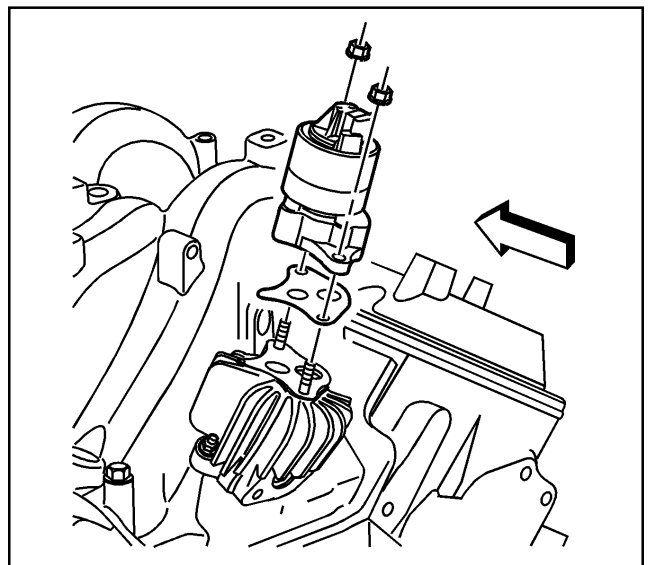

471008

7. Remove the EGR vacuum regulator bolts, EGR vacuum regulator and EGR vacuum regulator gasket.
8. Discard the EGR vacuum regulator gasket.

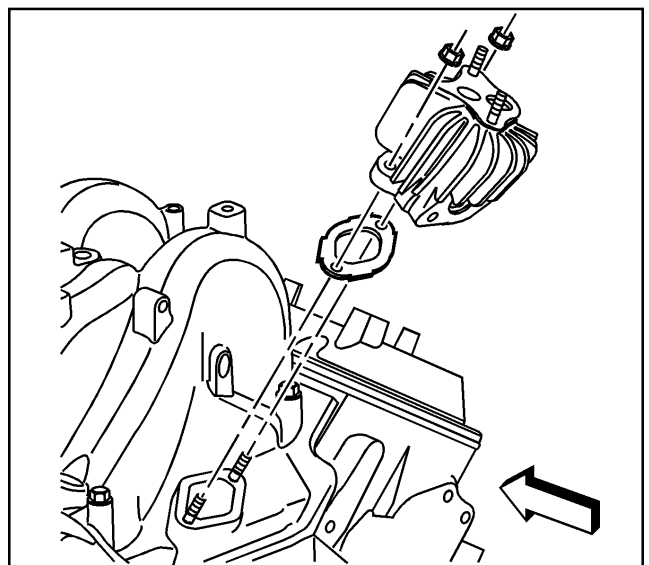

471009

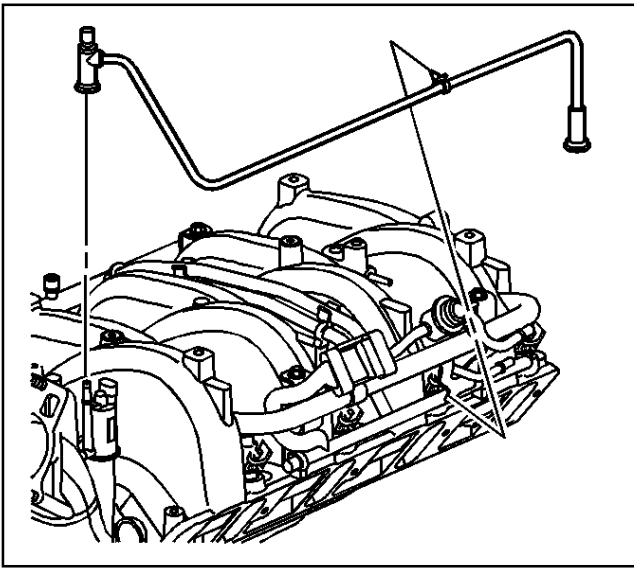

471013

9. Remove the purge solenoid vacuum hose.

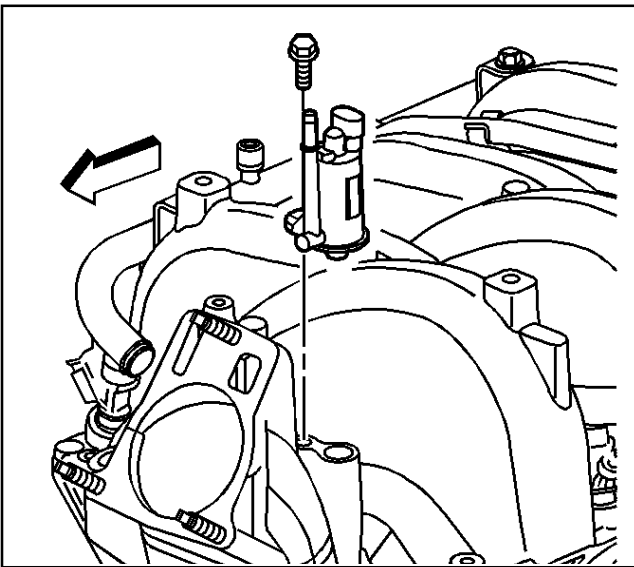

471015

10. Remove the purge solenoid bolt and the purge solenoid.
11. Inspect the purge solenoid seal for damage.

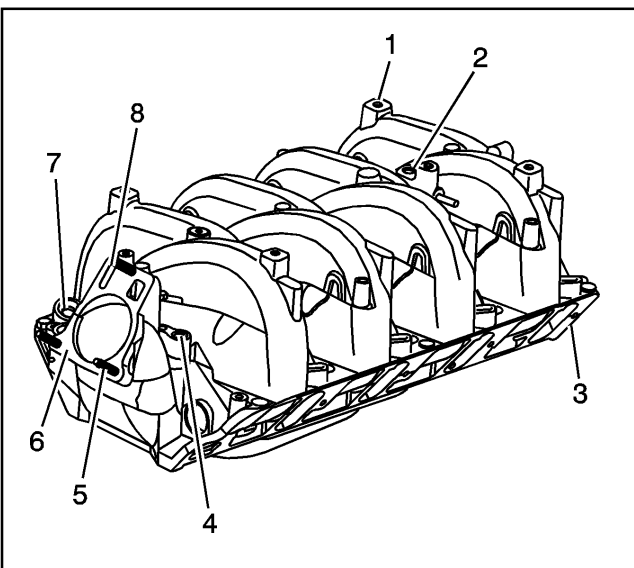

635688

### Intake Manifold Clean and Inspect

**Important:** Do not reuse the lower intake manifold gaskets or end seals.

1. Clean the lower intake manifold in an approved solvent.
  - Clean the intake manifold gasket sealing surfaces.
  - Clean all carbon from the EGR passages.
  - Clean all intake manifold ports.
  - Clean debris out of all bolt holes.

**Caution:** *Wear safety glasses in order to avoid eye damage.*

2. Dry the intake manifold with compressed air.
3. Inspect the following:
  - The intake manifold bolt holes (1) for cracks and/or damage.
  - The MAP sensor sealing surface (2) for damage.

- The purge solenoid sealing surface (4) for damage. The purge solenoid bolt has a sealer that may come off during removal of the bolt. Ensure all sealant is removed from the bolt hole.
- The intake manifold-to-cylinder head sealing surfaces (3) for damage.
- The EGR adapter mounting surface for damage.
- The throttle body studs (5) for damage and replace as necessary.
- The throttle body mounting surface (6) for damage.
- The oil fill tube hole (7) for signs of leakage and reseal as necessary.
- PCV port (8) for debris or varnish buildup.
- EGR pipe for damage.

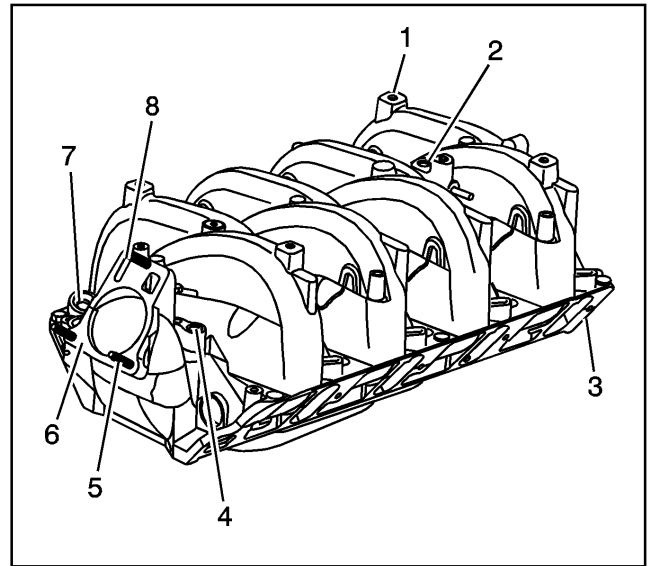

635688

**Intake Manifold Assemble**

1. Apply a very light film of clean engine oil to the purge solenoid seal.
2. Install the purge solenoid.

**Notice:** Refer to *Fastener Notice* in Cautions and Notices.

3. Apply thread sealer GM P/N 12345493 or equivalent to the threads of the purge solenoid bolt.
4. Install the purge solenoid bolt.

**Tighten**

Tighten the purge solenoid bolt to 10 N·m (88 lb in).

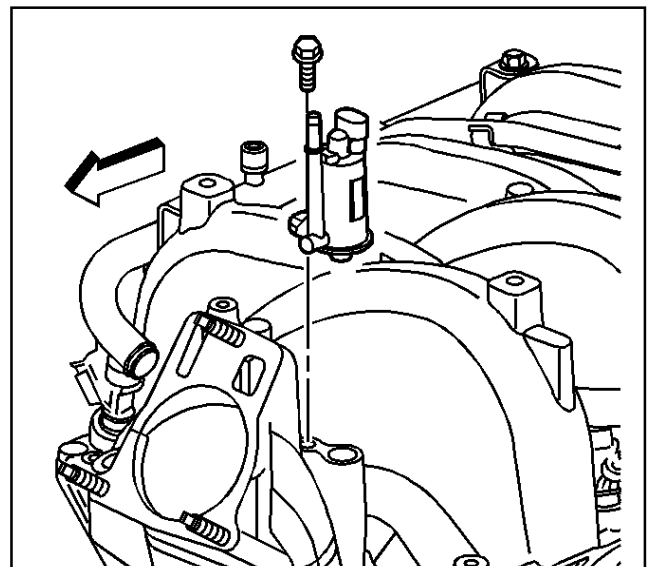

471015

5. Install the purge solenoid vacuum hose.

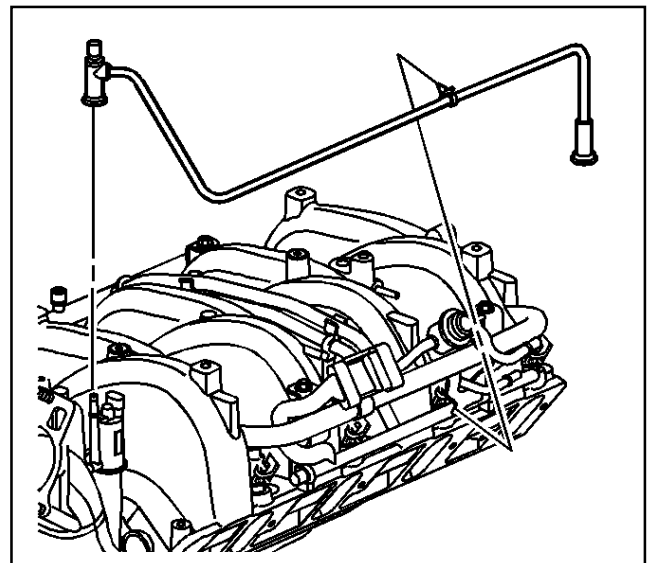

471013

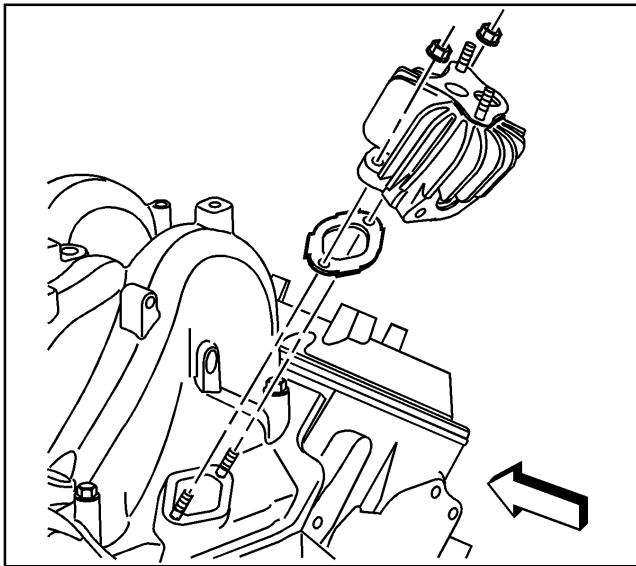

471009

6. Install the EGR adapter gasket.
7. Install the EGR adapter.
8. Install the EGR adapter nuts.

**Tighten**

Tighten the EGR adapter nuts to 30 N·m (22 lb ft).

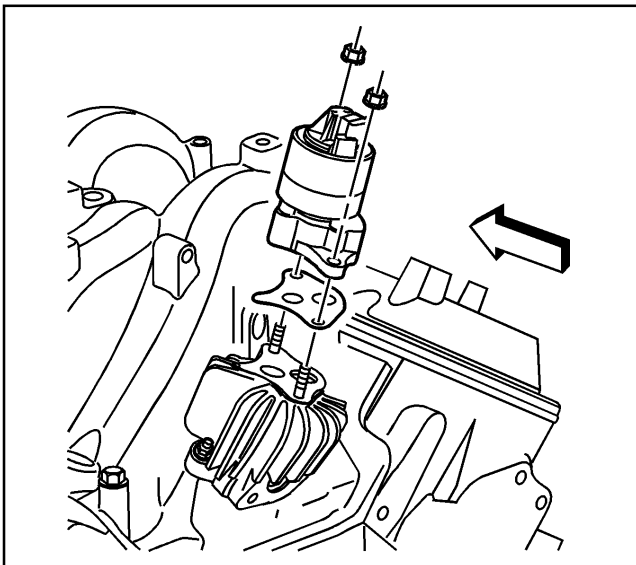

471008

9. Install the EGR valve gasket.
10. Install the EGR valve.
11. Install the EGR valve nuts.

**Tighten**

Tighten the EGR valve nuts to 30 N·m (22 lb ft).

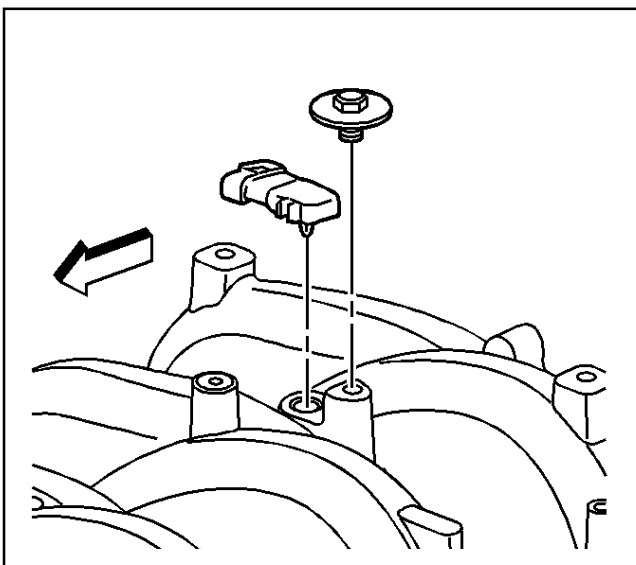

471023

**Important:** Lubricate the port of the MAP sensor with clean engine oil. Avoid dipping the sensor port directly into the lubricant or using a solid type of lubricant, as they may block the vacuum port signal.

12. Install the MAP sensor.
13. Install the MAP sensor bolt.

**Tighten**

Tighten the MAP sensor bolt to 12 N·m (106 lb in).

14. Install the throttle body gasket.
15. Install the throttle body.
16. Install the throttle body nuts.

**Tighten**

Tighten the throttle body nuts to 10 N·m (88 lb in).

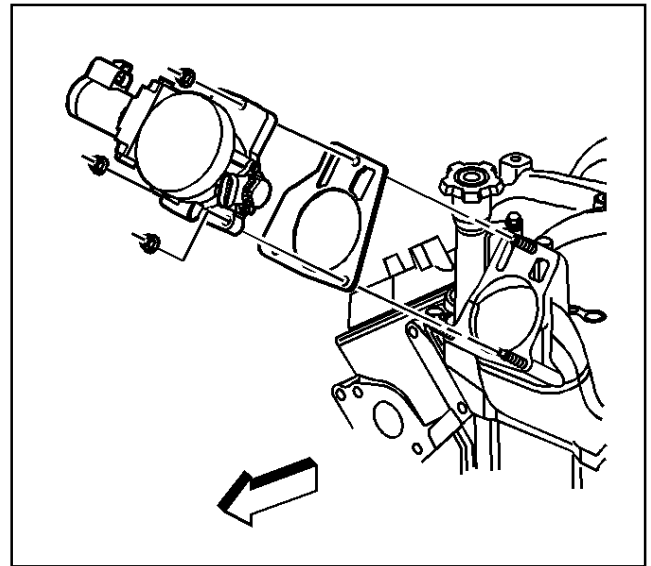

470760

**Exhaust Manifold Clean and Inspect**

1. Clean the exhaust manifolds in solvent.

**Caution: Wear safety glasses in order to avoid eye damage.**

2. Dry the components with compressed air.
3. Inspect the exhaust manifolds for the following:
  - Damage to the gasket sealing surfaces
  - Damaged exhaust valve recirculation (EGR) pipe mounting studs (if applicable)
  - Damage to the exhaust manifold studs
  - Broken or damaged heat shields
  - Cracks in the exhaust manifold
  - Restrictions with the exhaust passages

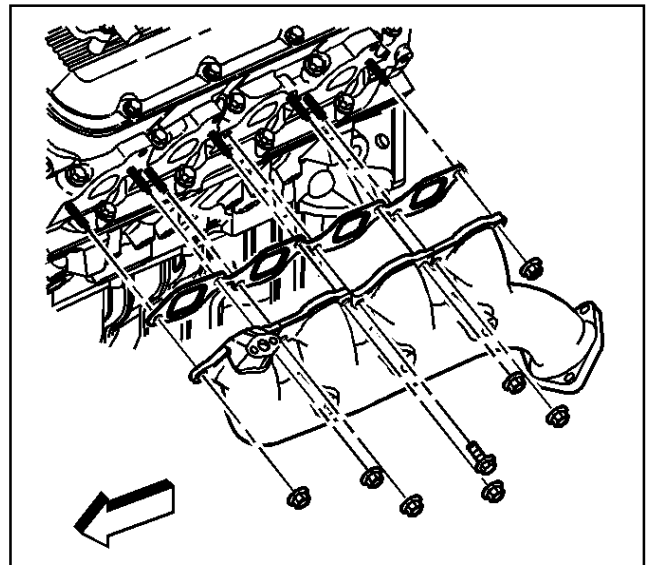

470679

4. Measure the alignment or surface flatness of the exhaust manifold flanges, using a straight edge and a feeler gauge. Exhaust manifold surface flatness must not exceed 0.254 mm (0.01 in).
5. If the surface flatness is not within specifications, the exhaust manifold is warped and must be replaced.

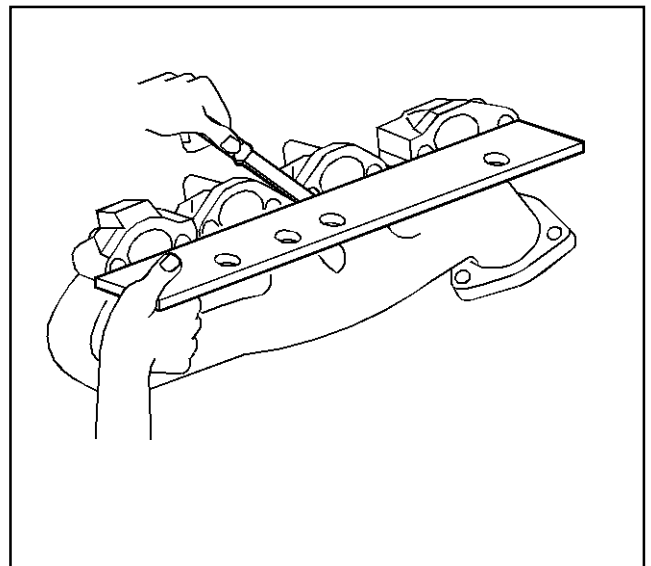

66607

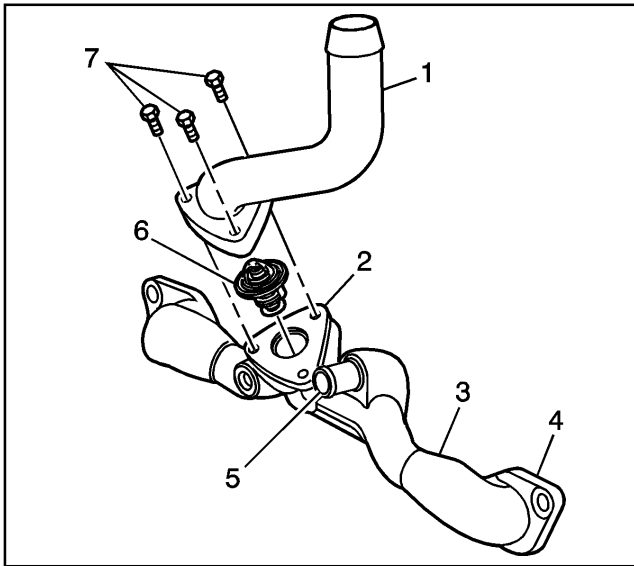

635646

## Water Crossover Clean and Inspect

### Cleaning Procedure

1. Clean the water crossover (3) and thermostat housing (1) in solvent.

**Caution:** *Wear safety glasses in order to avoid eye damage.*

2. Dry the water crossover and thermostat housing with compressed air.

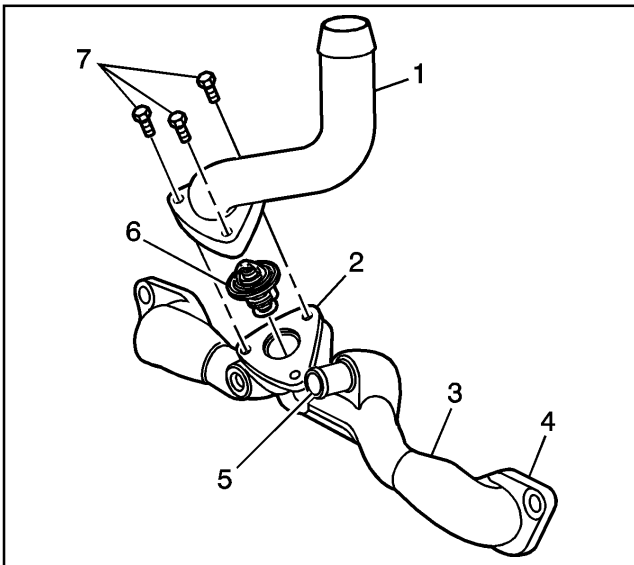

635646

### Inspection Procedure

1. Inspect the water crossover (3) for the following:
  - Corrosion or damage to the gasket sealing surfaces (4)
  - Corrosion or damage to the bypass hose fitting (5)
  - Corrosion or damage to the threads for the thermostat housing (2)
2. Inspect the thermostat housing (1) for corrosion and/or damage.
3. Repair or replace the water crossover and/or thermostat housing as necessary.

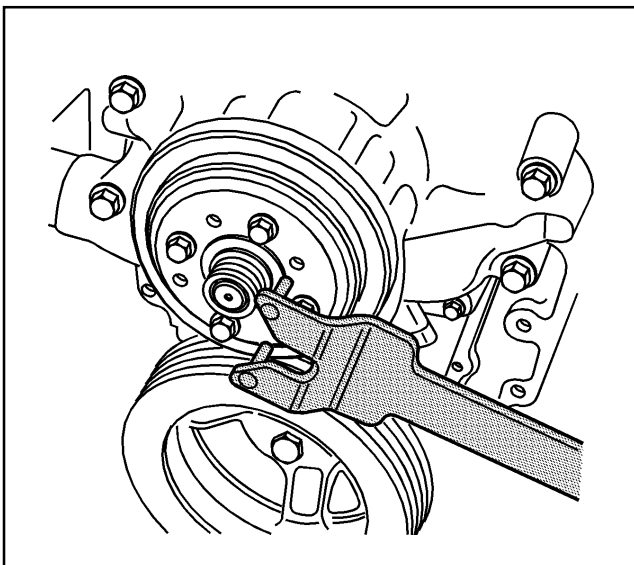

## Water Pump Clean and Inspect

### Tools Required

J 41240 Fan Clutch Wrench

1. Remove the water pump pulley bolts using the J 41240 in order to prevent water pump pulley rotation.
2. Remove the water pump pulley.
3. Inspect the water pump pulley for damage at the belt contact area and the pulley-to-water pump mounting surface.

**Important:** Do not immerse the water pump in solvent. The solvent may enter the water pump's permanently lubricated bearings and cause premature bearing failure.

4. Clean all excess dirt and debris from the water pump housing.
5. Inspect the water pump for the following:
  - Leakage at the hose fitting (1)
  - Leakage at the water pump weep hole (3)  
A stain around the weep hole is acceptable. If leakage occurs (dripping) with the engine running and the cooling system pressurized, replace the water pump.
  - Gasket sealing surfaces (2) for excessive scratches or gouging
  - Restrictions within the internal coolant passages (6)
  - Excessive side-to-side play in the pulley shaft (5)  
If the shaft end play exceeds 0.381 mm (0.015 in), replace the water pump
  - Rotate the pump shaft by hand and inspect for roughness of operation
    - If the hub wobbles, is noisy or feels rough when rotated, replace the water pump.
    - The shaft and fan hub must turn straight and smoothly.
  - Damage to threaded bolt holes (4)
  - Damage to the fan clutch mounting threads (5)

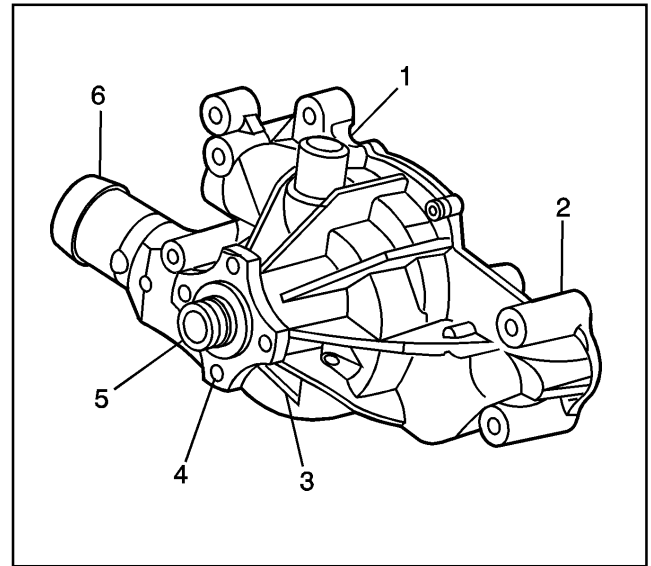

635691

6. Install the water pump pulley.

**Notice:** Refer to *Fastener Notice* in Cautions and Notices.

7. Install the water pump pulley bolts using the J 41240 in order to prevent water pump pulley rotation.

**Tighten**

Tighten the water pump pulley bolts to 25 N·m (19 lb ft).

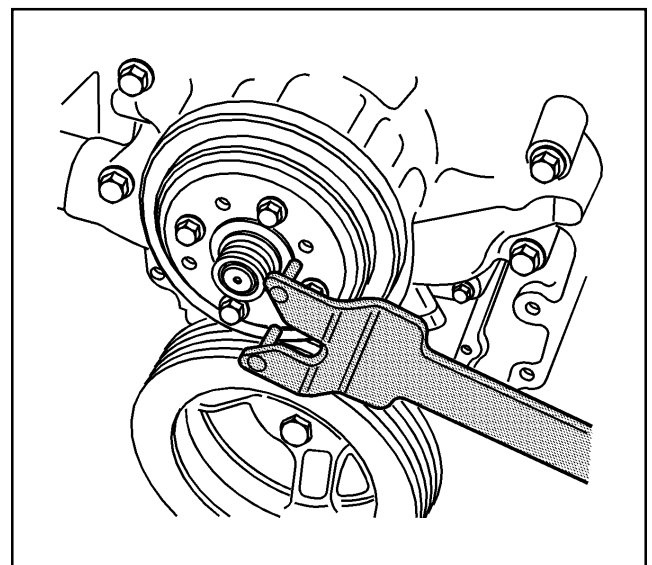

635640

## Thread Repair

### Tools Required

J 39345 Thread Repair Kit

The following procedure is used to accomplish proper and durable thread repairs in the cylinder head and cylinder block.

**Important:** Take appropriate precautions to assure that machining chips will not remain inside the engine. For example, block all intake passages, oil drainback holes and exhaust passages with a towel or tape before performing thread repairs.

1. Select the proper size drill as indicated in the schematic charts found in Thread Repair Specifications for the hole being repaired.
2. Drill out the damaged threads to the original depth, or completely through for through holes.

**Caution:** *Wear safety glasses in order to avoid eye damage.*

3. Clean out the hole using compressed air with a shop rag wrapped around the air spout to prevent aluminum chips from leaving the hole.
4. Select the correct size tap, using the appropriate chart for the hole being repaired.
5. Coat the tap and the hole with spray machining oil.
6. Tap the hole to the original depth. In order to clean the threads, reverse the rotation of the tap periodically.
7. Use aluminum safe solvent to clean out all of the aluminum chips.
8. Apply compressed air, with a shop towel wrapped around the air spout, in order to retain the chips forced out of the hole.
9. Tap the hole again to clean the threads. The tap should thread in with little resistance.

**Important:** Make sure all of the aluminum chips are cleared from the hole.

10. Use aluminum safe solvent to clean out all of the aluminum chips.
11. Apply compressed air, with a shop towel wrapped around the air spout, in order to retain the chips forced out of the hole.
12. Use a flashlight to confirm that all of the chips are removed from the hole.
13. Continue to clean the hole until all of the aluminum chips are cleared.
14. Install the heli-coil insert as follows:
  - 14.1. In order to determine the correct size installation tool and length insert, refer to the appropriate picture and chart.

- 14.2. Screw the insert on the mandrel of the installation tool until the driving tang is fully engaged in the driving contour.
- 14.3. Coat the insert with spray machining oil.
- 14.4. Install the insert as follows:
  - 14.4.1. Slide the prewinder over the mandrel and insert.
  - 14.4.2. Rotate the mandrel clockwise until 1 or 2 threads of the insert are threaded into the prewinder.
  - 14.4.3. Place the insert in position on the threaded hole being repaired.
  - 14.4.4. Rotate the mandrel clockwise until the insert is flush with the top surface of the threaded hole.
  - 14.4.5. Remove the prewinder except when repairing cylinder head bolts.
  - 14.4.6. Continue to install the insert until reaching the original thread depth.
  - 14.4.7. Remove the mandrel.
- 14.5. Remove the driving tang from the thread insert as follows. The tang must be removed in order to allow passage of the fastener through the insert.
  - 14.5.1. Place the square end of the punch, no chamfer, on the tang after installation.
  - 14.5.2. Strike the punch sharply with the hammer. The tang will break off at the notch.
15. Clean the hole using compressed air. Take appropriate steps to assure that the chips are not blown into the engine.

### Service Prior to Assembly

- Dirt will cause premature wear of the rebuilt engine. Clean all the components.
- Use the proper tools to measure the components when checking for excessive wear. Components not within the manufacturer's specification must be repaired or replaced.
- When the components are reinstalled into an engine, return the components to their original location, position and direction.
- During assembly, lubricate all the moving parts with clean engine oil (unless otherwise specified). This will provide initial lubrication when the engine is first started.





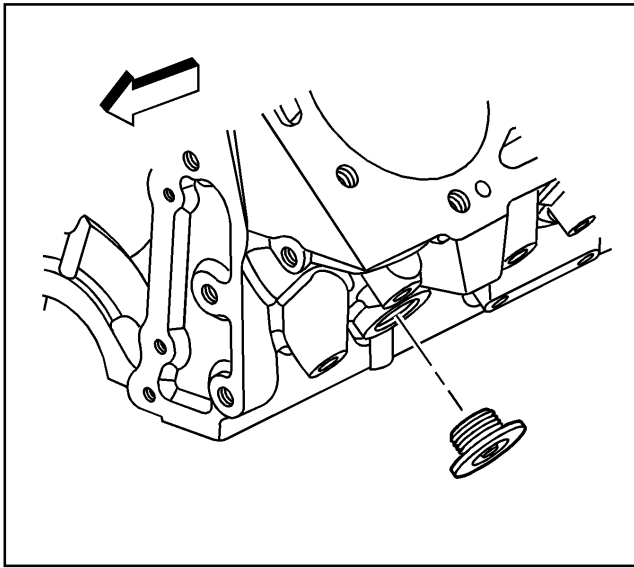

635657

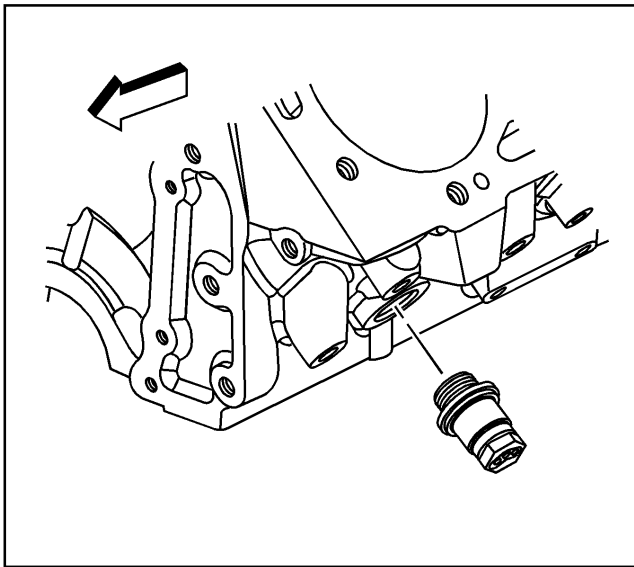

635660

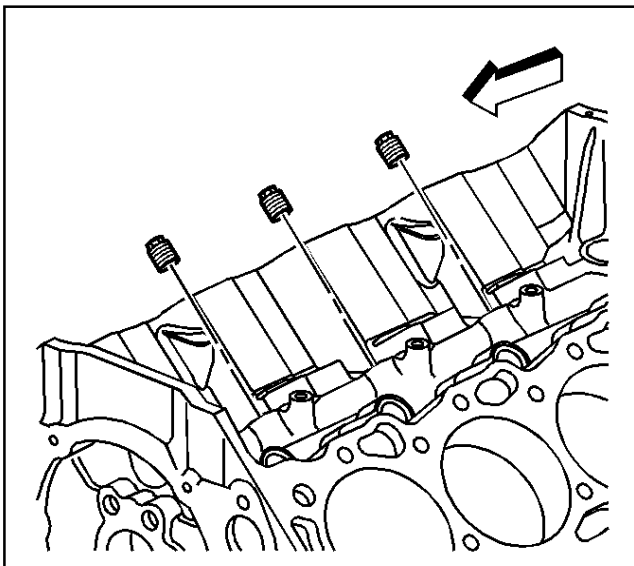

471137

## Engine Block Plug Installation

### Tools Required

J 41712 Oil Pressure Sending Unit Socket

**Notice:** Refer to *Fastener Notice* in Cautions and Notices.

1. Apply sealant GM P/N 12346004 or equivalent to the threads of the coolant hole plug.
2. Install the engine coolant hole plug into the block.

### Tighten

Tighten the engine coolant hole plug to 60 N·m (40 lb ft).

3. Apply sealant GM P/N 12346004 or equivalent to the threads of the engine block heater (if applicable).
4. Install the engine block heater into the block.

### Tighten

Tighten the engine block heater to 60 N·m (40 lb ft).

5. Apply sealant GM P/N 12346004 or equivalent to the threads of the oil gallery plugs.
6. Install the engine block top oil gallery plugs.

### Tighten

Tighten the top oil gallery plugs to 20 N·m (15 lb ft).

- 7. Apply sealant GM P/N 12346004 or equivalent to the threads of the oil gallery plugs.
- 8. Install the engine block left side oil gallery plugs.

**Tighten**

Tighten the left oil gallery plugs to 30 N·m (22 lb ft).

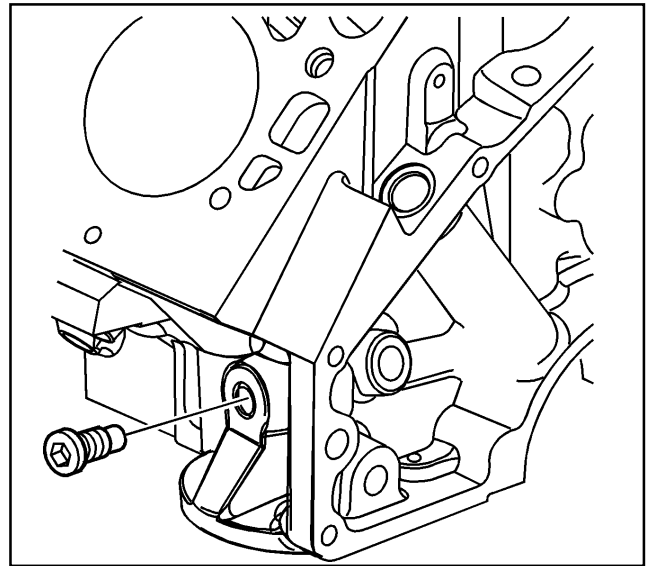

471138

- 9. Apply sealant GM P/N 12346004 or equivalent to the threads of the oil gallery plugs.
- 10. Install the front oil gallery plugs.

**Tighten**

Tighten the front oil gallery plugs to 30 N·m (22 lb ft).

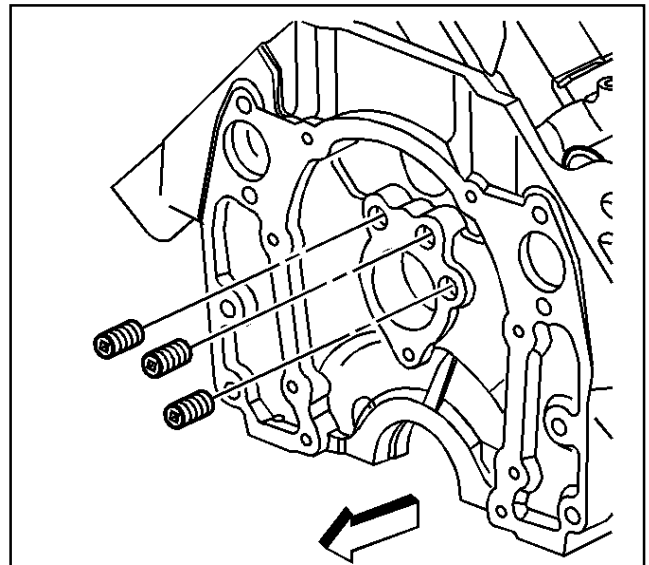

471133

- 11. Apply sealant GM P/N 12346004 or equivalent to the threads of the oil gallery plugs.
- 12. Install the rear oil gallery plugs.

**Tighten**

Tighten the rear oil gallery plugs to 30 N·m (22 lb ft).

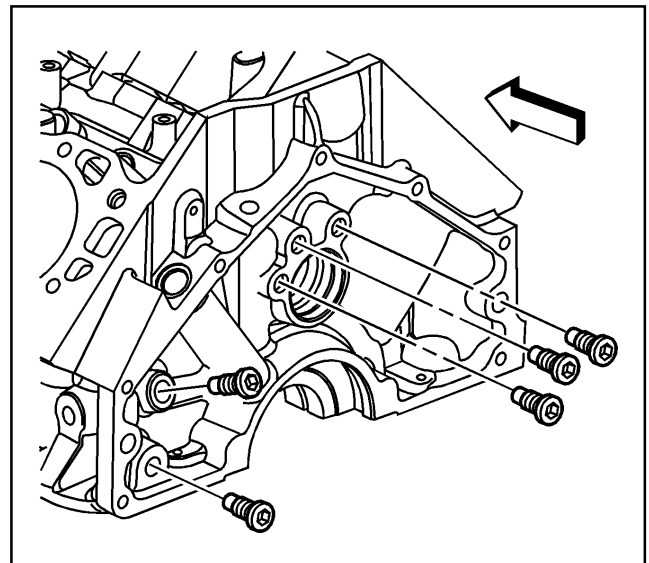

471134

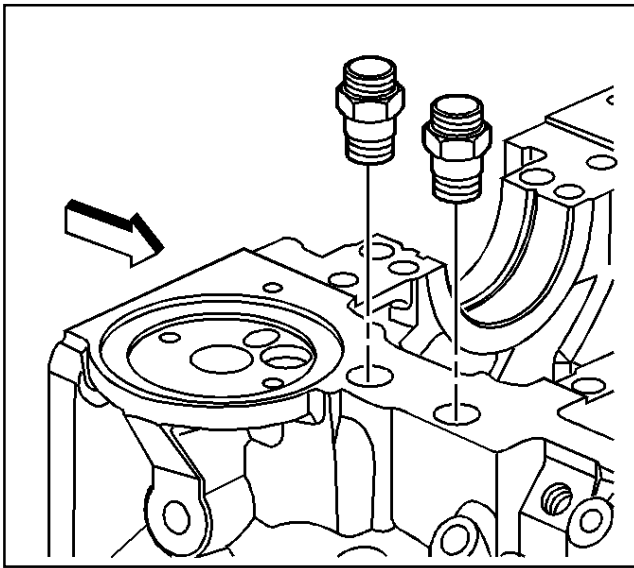

471126

13. Apply sealant GM P/N 12346004 or equivalent to the threads of the engine block oil cooler hose fittings (with oil cooler).
14. Install the engine block oil cooler hose fittings (with oil cooler).

**Tighten**

Tighten the engine block oil cooler hose fittings to 23 N·m (17 lb ft).

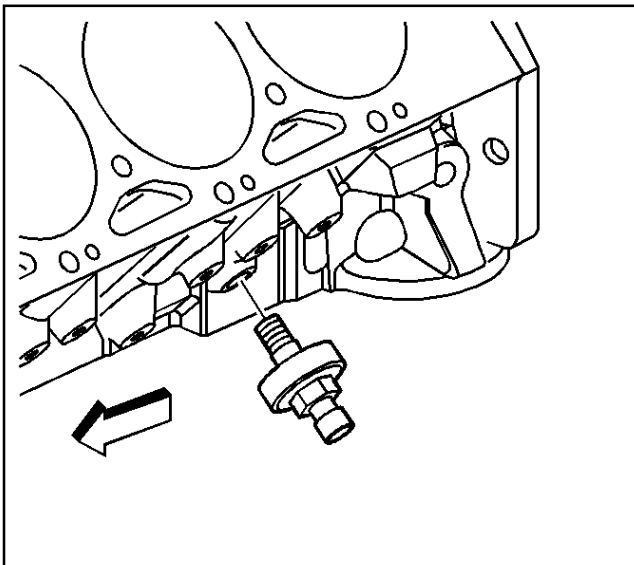

471081

**Important:** Do not overtighten the knock sensor or engine damage may occur.

15. Install the left knock sensor into the engine block.

**Tighten**

Tighten the left knock sensor to 20 N·m (15 lb ft).

16. Install the left side knock sensor shield.
17. Install the left side knock sensor shield bolts.

**Tighten**

Tighten the left side knock sensor shield bolts to 12 N·m (106 lb in).

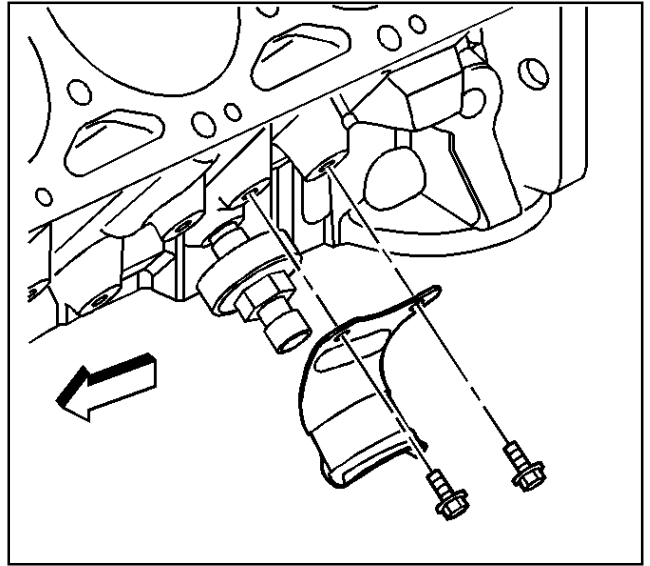

471100

**Important:** Do not overtighten the knock sensor or engine damage may occur.

18. Install the right knock sensor into the engine block.

**Tighten**

Tighten the right knock sensor to 20 N·m (15 lb ft).

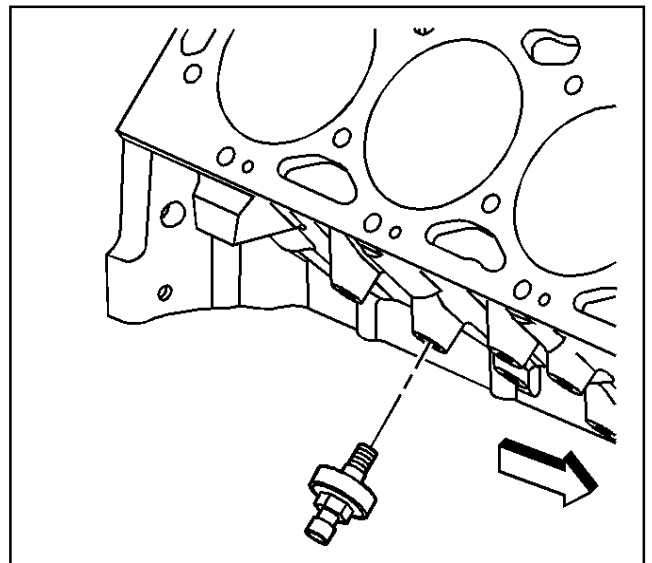

471076

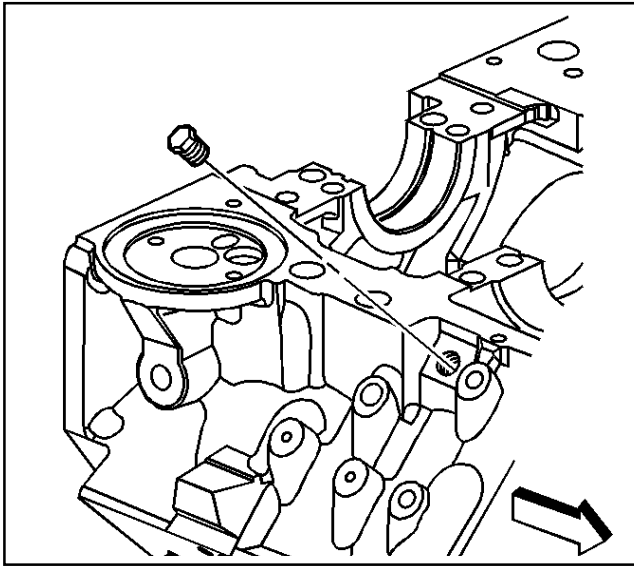

470568

19. Apply sealant GM P/N 12346004 or equivalent to the threads of the engine block coolant drain hole plugs.
20. Install the engine block coolant drain hole plugs.

**Tighten**

Tighten the engine coolant drain hole plugs to 20 N·m (15 lb ft).

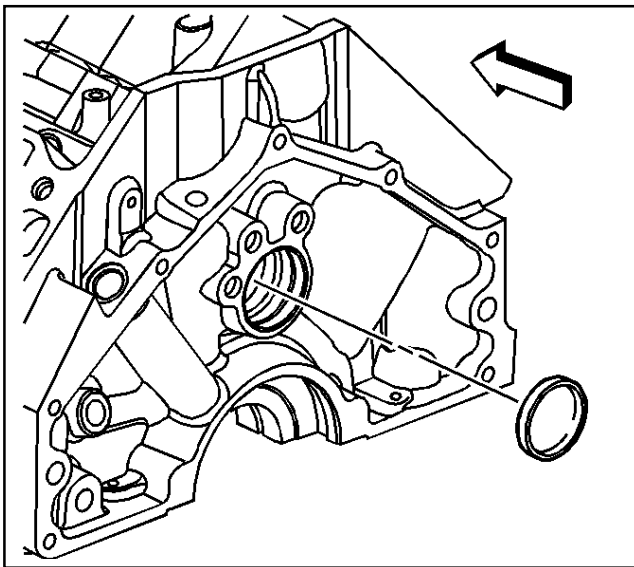

471118

21. Apply sealant GM P/N 12345493 or equivalent to the engine block camshaft rear bearing hole.

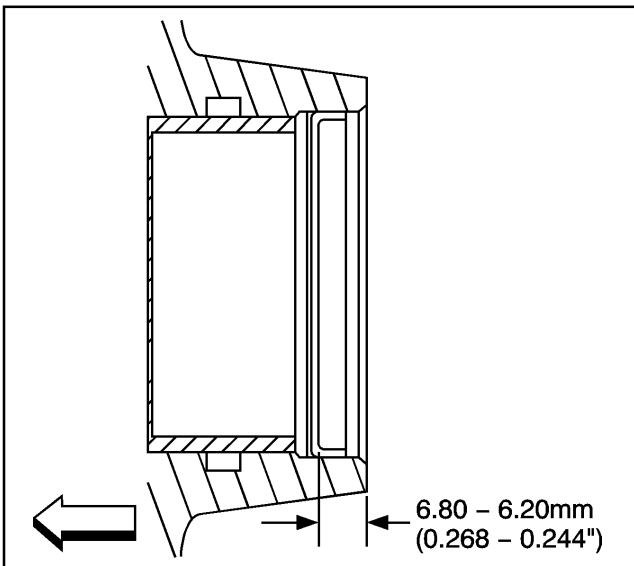

471122

22. Install a NEW camshaft rear bearing hole plug to the proper depth.

23. Apply sealant GM P/N 12346004 or equivalent to the threads of the oil pressure sensor.
24. Install the oil pressure sensor.

**Tighten**

Using the J 41712, tighten the oil pressure sensor to 30 N·m (22 lb ft).

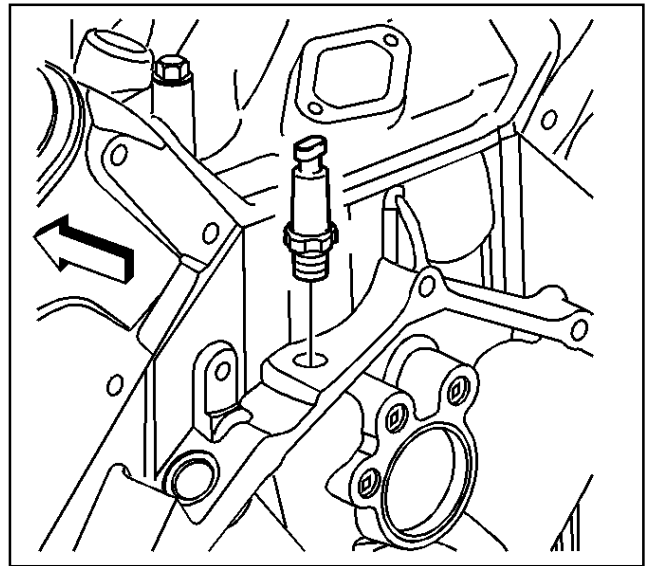

471089

**Oil Filter Adapter Installation**

1. If removed, install the new oil bypass valves. Stake the tangs on the oil bypass valves.

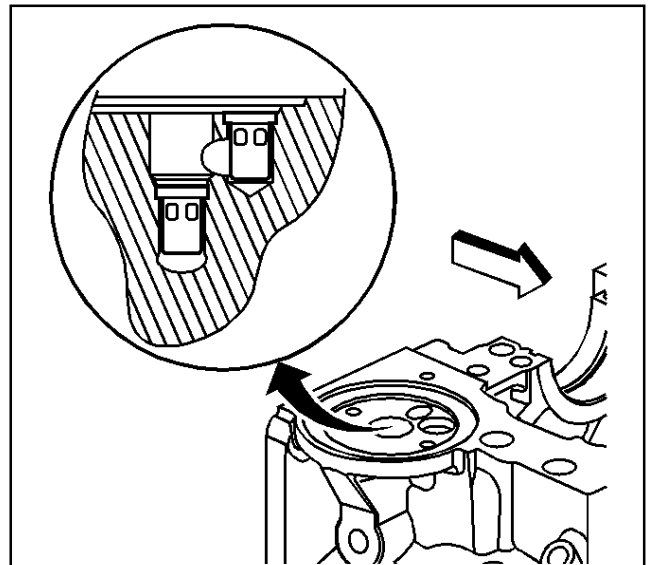

471143

**Notice:** Refer to *Fastener Notice* in Cautions and Notices.

2. Install the oil filter fitting.

**Tighten**

Tighten the oil filter fitting to 66 N·m (49 lb ft).

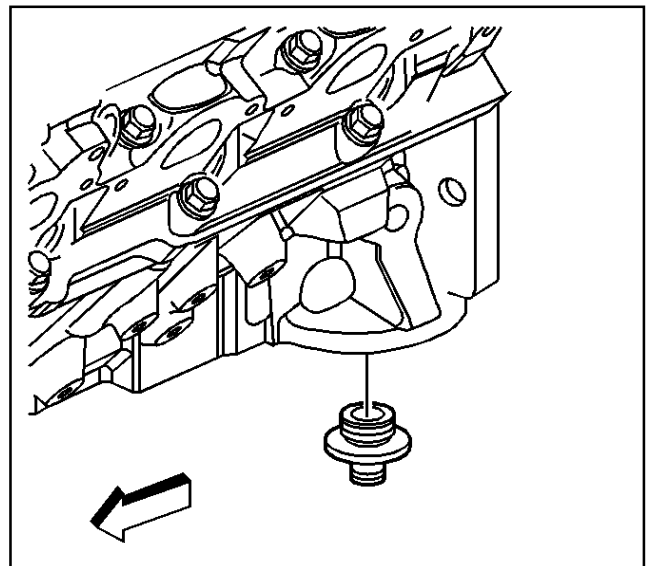

471026

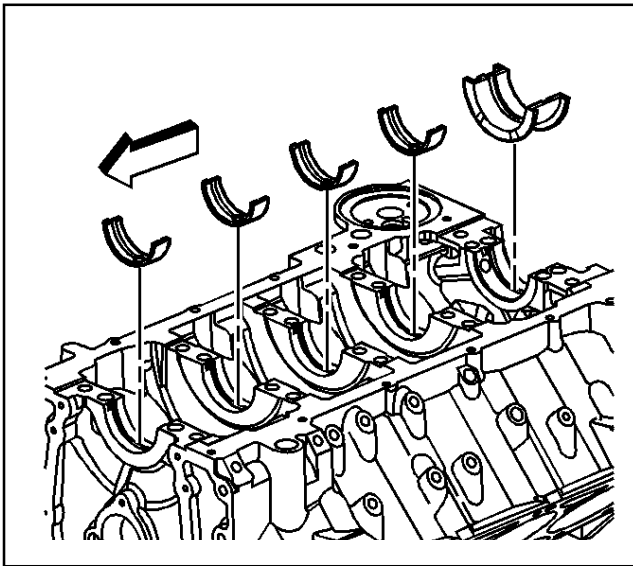

471041

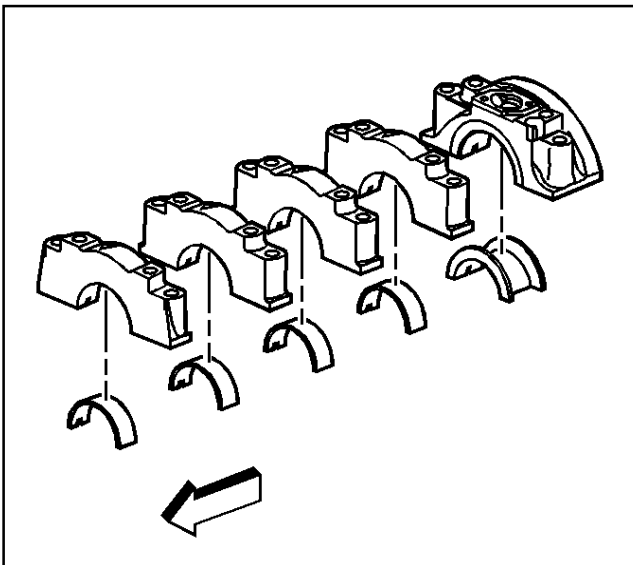

471044

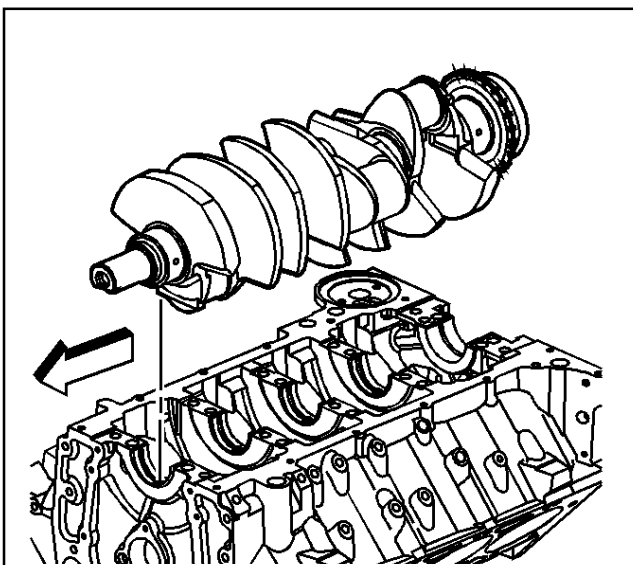

471047

## Crankshaft and Bearings Installation

### Tools Required

*J 8001* Dial Indicator Set

*J 36660-A* Electronic Torque Angle Meter

### Important:

- Lubricate the crankshaft bearings and crankshaft with clean engine oil.
  - If undersized bearings are used, ensure that the bearings are fitted to the proper journals.
1. Install the crankshaft upper bearings into the engine block. Apply clean engine oil to the bearing surfaces.

2. Install the crankshaft lower bearings into the crankshaft bearing caps. Apply clean engine oil to the bearing surfaces.

**Important:** Care should be taken when installing the crankshaft so the crankshaft position sensor reluctor ring is not damaged. If the reluctor ring becomes damaged, the crankshaft must be replaced.

3. Install the crankshaft.



4. Apply a 13 mm (0.500 in) light film of GM P/N 1052942 or equivalent to the rear bearing cap sealing face or to the rear bearing cap channel of the engine block. Apply the sealant from the center of the rear thrust bearing pocket to the edge of the channel.

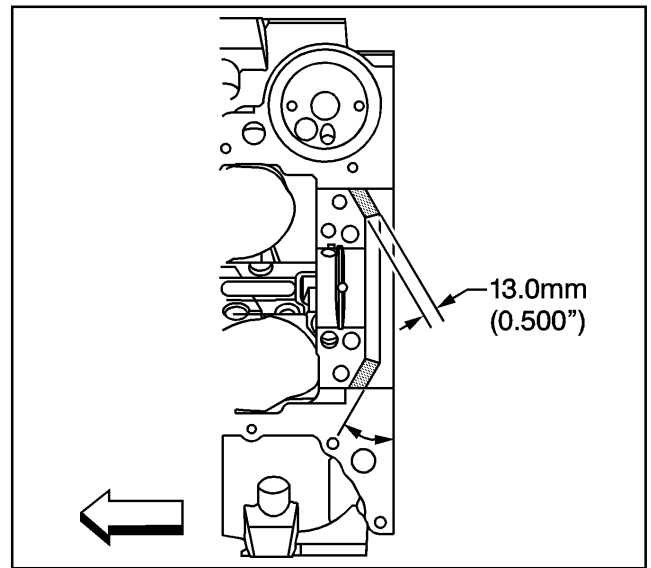

647705

**Notice:** In order to prevent the possibility of cylinder block or crankshaft bearing cap damage, the crankshaft bearing caps are tapped into the cylinder block cavity using a brass, lead or leather mallet before the attaching bolts are installed. Do not use attaching bolts to pull the crankshaft bearing caps into the seats. Failure to use this process may damage a cylinder block or a bearing cap.

**Important:** Care should be taken when installing the rear bearing cap to prevent damage to the crankshaft position sensor reluctor wheel. If the reluctor wheel is damaged, the crankshaft must be replaced.

**Important:** Ensure that the triangle symbols on the crankshaft bearing caps are facing the front of the engine.

5. Install the crankshaft bearing caps.

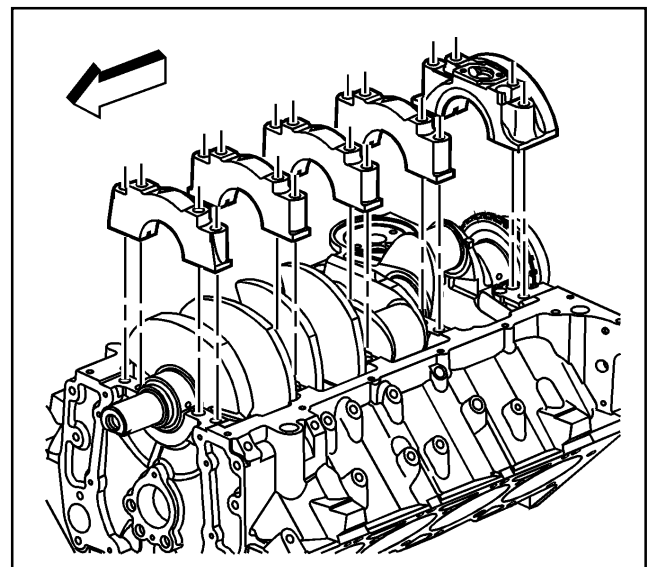

679831

**Notice:** Refer to *Fastener Notice* in Cautions and Notices.

**Important:** Tighten the crankshaft bearing cap inner bolts before tightening the crankshaft bearing cap outer studs.

6. Install the crankshaft bearing cap bolts and studs.

**Tighten**

- 6.1. Tighten the crankshaft bearing cap inner bolts to 30 N·m (22 lb ft).
- 6.2. Tighten the crankshaft bearing cap outer studs to 30 N·m (22 lb ft).
- 6.3. Using the J 36660-A, tighten the crankshaft bearing cap inner bolts an additional 90 degrees.
- 5.4. Using the J 36660-A, tighten the crankshaft bearing cap outer studs an additional 80 degrees.

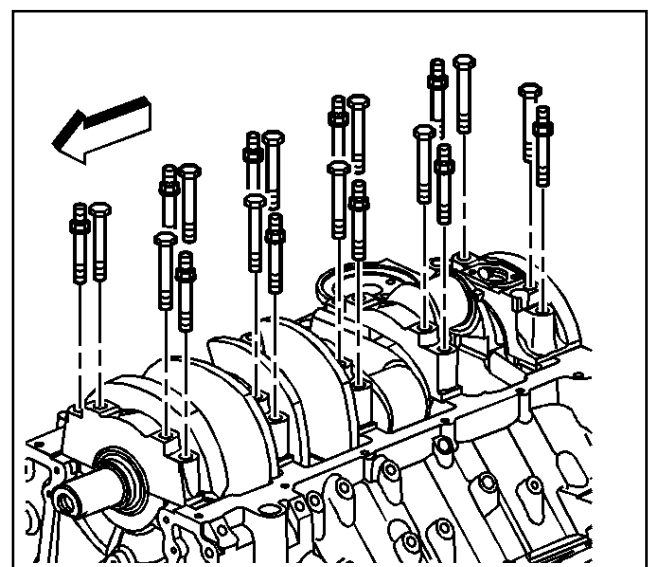

471055

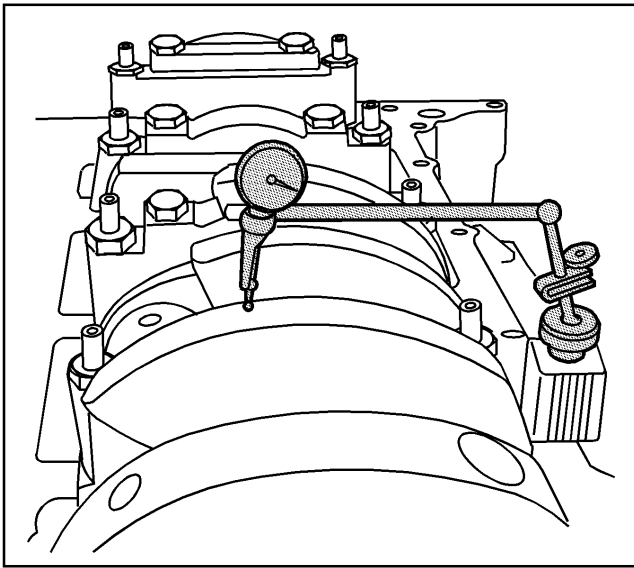

677804

7. Measure the crankshaft end play as follows:
  - 7.1. Install the J 8001 or equivalent to the cylinder block, with the dial indicator plunger against one of the counterweights of the crankshaft.
  - 7.2. Firmly thrust the crankshaft first rearward, then forward. This will line up the rear crankshaft bearing and the crankshaft thrust surfaces
  - 7.3. With the crankshaft pushed forward, zero the dial indicator. Move the crankshaft rearward, and read the end play measurement on the dial indicator. An optional method is to insert a feeler gauge between the crankshaft and the bearing surface and measure the clearance. Refer to *Engine Mechanical Specifications*.
  - 7.4. If the correct end play cannot be obtained, inspect for the following conditions:
    - Verify that the correct size crankshaft bearing has been installed. Refer to *Engine Mechanical Specifications*.
    - Inspect the crankshaft thrust wall surface(s) for wear and/or excessive runout. Refer to *Engine Mechanical Specifications*.
  - 7.5. Inspect the crankshaft for binding. Turn the crankshaft to check for binding. If the crankshaft does not turn freely, loosen the crankshaft bearing bolts and studs, one cap at a time, until the tight bearing is located. The following condition(s) could cause a lack of clearance at the bearing:
    - Burrs on the bearing cap
    - Foreign material between the bearing and the block
    - Foreign material between the bearing and the bearing cap
    - Damaged bearing
    - Improper size bearing

**Important:** Ensure that the crankshaft position sensor is fully seated against the crankshaft reluctor ring. The upper flange on the sensor MAY NOT seat against the engine block.

**Important:** The crankshaft position sensor bolt has a thread sealant applied to the threads. The thread sealant may have come off during the removal of the bolt. Ensure that the bolt holes is clean of any debris before installing the crankshaft sensor bolt.

8. Inspect both crankshaft position sensor O-rings for cuts, cracks, tears or damage. Replace the O-rings as needed. Lubricate the crankshaft position sensor O-rings with clean engine oil.
9. Install the crankshaft position sensor into the engine block.  
There may be a slight resistance as the O-rings seat into the engine block.
10. Apply thread sealer GM P/N 12345493 or equivalent to the crankshaft position sensor bolt.
11. Install the crankshaft position sensor bolt.

**Tighten**

Tighten the crankshaft position sensor bolt to 12 N·m (106 lb in).

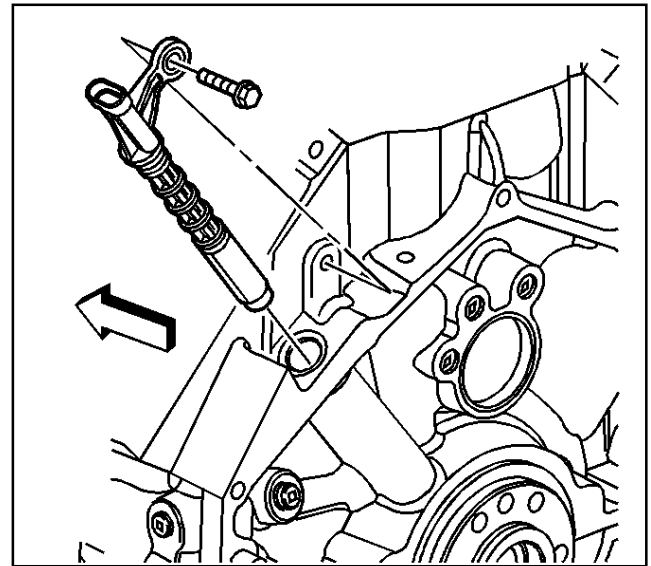

470801

**Crankshaft Rear Oil Seal Installation**

**Tools Required**

J 42849 Crankshaft Rear Seal Installer

**Important:** Crankshaft rear oil seal and engine flywheel installation requires adequate space for installation. If the engine stand does not allow suitable space to use the J 42849, install the crankshaft rear oil seal and engine flywheel with the engine properly supported on the floor.

1. Make sure the crankshaft rear chamfer is free of grit, loose rust and burrs. Correct as needed.
2. Apply a very light film of oil onto the crankshaft sealing surface.  
DO NOT apply oil to the sealing surface of the engine block.
3. Install the seal on the J 42849.
4. Position the J 42849 against the crankshaft. Thread the attaching screws into the tapped holes in the crankshaft.
5. Tighten the screws securely with a screwdriver in order to ensure that the seal is installed squarely over the crankshaft.
6. Rotate the center nut until the J 42849 bottoms.
7. Remove the J 42849.

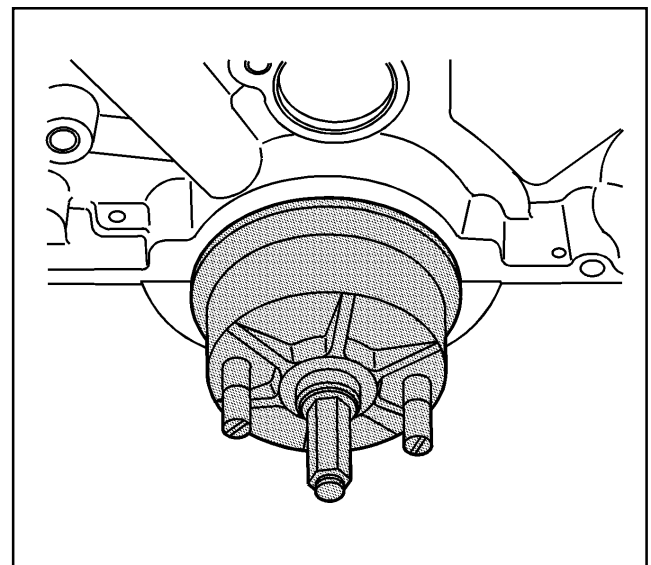

640011

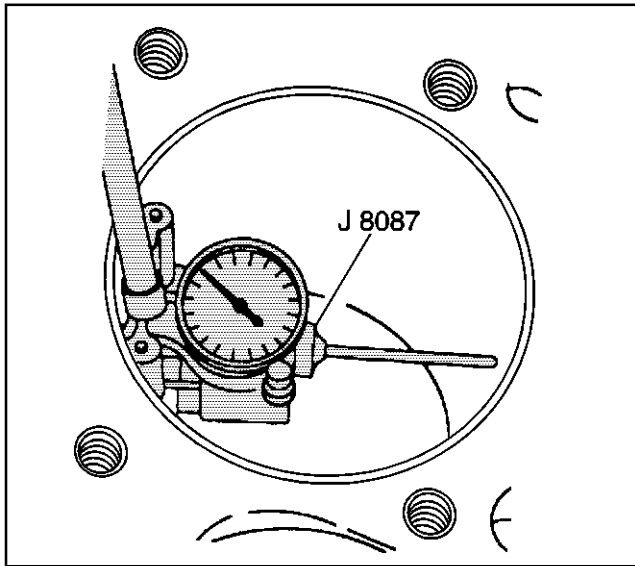

4972

## Piston, Connecting Rod and Bearing Installation

### Piston Selection

#### Tools Required

J 8037 Piston Ring Compressor

J 8087 Cylinder Bore Checking Gauge

**Important:** The coating on the piston allows for an interference fit between the piston and the bore. The piston diameter can NOT be measured accurately because the piston coating is not a consistent thickness. Do NOT measure the piston diameter.

To select the correct piston for installation, the cylinder bore must be measured. If the cylinder bore diameter is within service specifications, install the original piston/connecting rod assembly. A used piston/connecting rod assembly may be reinstalled if, after cleaning and inspection, the piston is not damaged. If the cylinder bore is NOT within specifications, the cylinder must be resized to accept a new, oversized piston.

For proper piston fit, the engine block cylinder bores should not have excessive wear or taper.

1. Inspect the engine block cylinder bore. Refer to *Cylinder Boring and Honing*.
2. Inspect the piston/connecting rod assembly for damage. Refer to *Piston, Connecting Rod and Bearings Clean and Inspect*.
3. Use the J 8087 in order to measure the cylinder bore diameter. Refer to *Engine Block Clean and Inspect*.

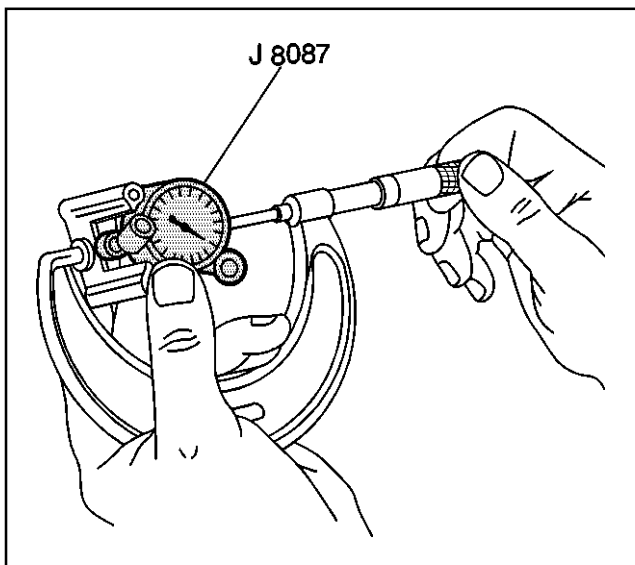

4974

4. Measure the J 8087 with a micrometer and record the reading.
5. Compare the cylinder bore measurement to the specifications. Refer to *Engine Mechanical Specifications*.
  - 5.1. If the cylinder bore is within specifications, select the original piston or a new, original size piston.
  - 5.2. If the cylinder bore is not within specifications, select the next oversized piston/connecting rod assembly, then bore and hone the cylinder bore to fit the oversize piston.



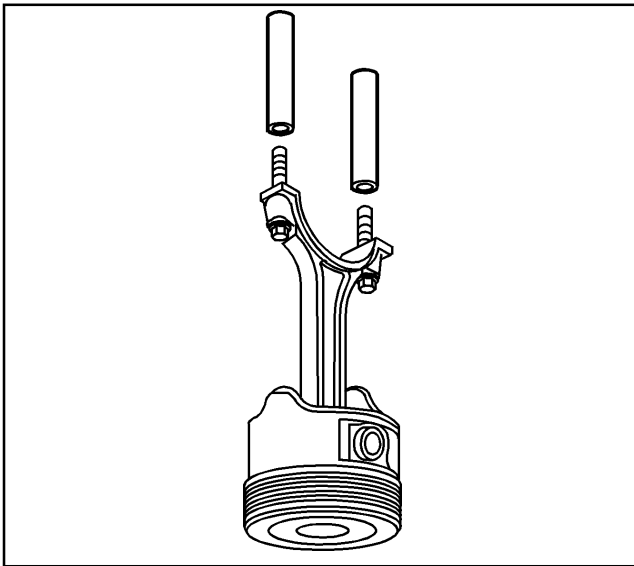

639532

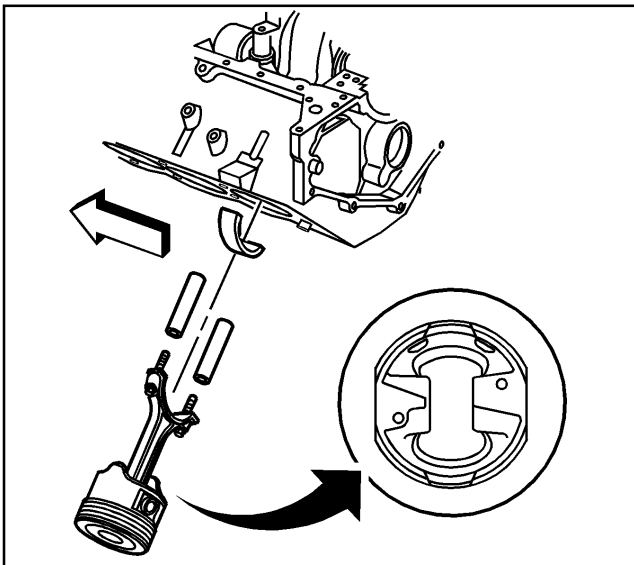

639536

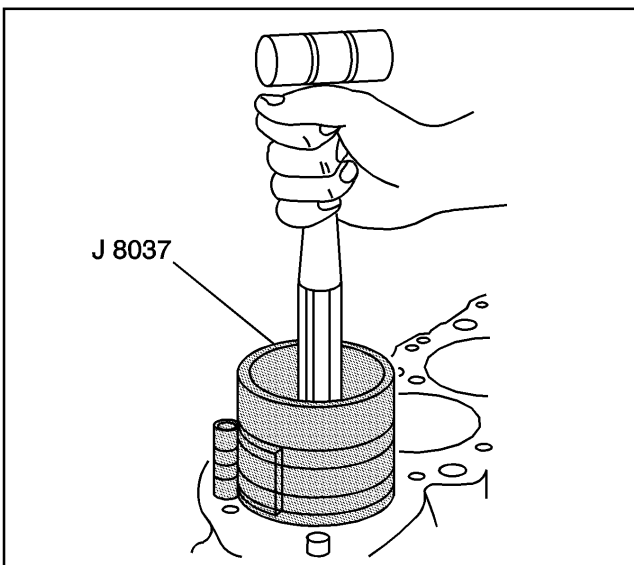

5159

### Piston Installation

1. Coat the following components with clean engine oil:
  - The piston
  - The piston rings
  - The cylinder bore
  - The bearing surfaces
2. Install rubber fuel line onto the connecting rod bolts.

**Important:** The mark on the top of the piston must face the front of the engine block. When assembled, the flanges on the connecting rod and cap should face to the front of the block on the left bank and to the rear of the block on the right bank.

3. Install the piston, connecting rod and upper connecting rod bearing through the top of the engine block.
4. Install the J 8037 onto the piston and compress the piston rings.
5. Use the J 8037 and lightly tap the top of the piston with a wooden hammer handle.
6. Hold the J 8037 firmly against the engine block until all of the piston rings have entered the cylinder bore.

7. Use the rubber fuel line in order to guide the connecting rod onto the crankshaft journal.
8. Remove the rubber fuel line.

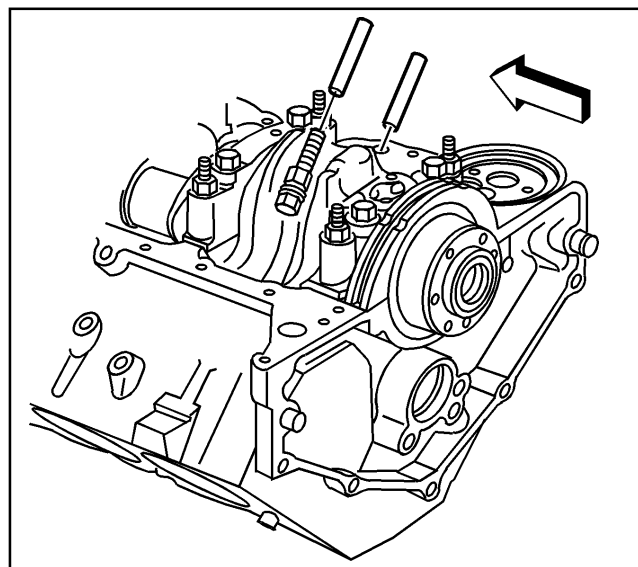

639533

9. Install the connecting rod cap and lower connecting rod bearing.

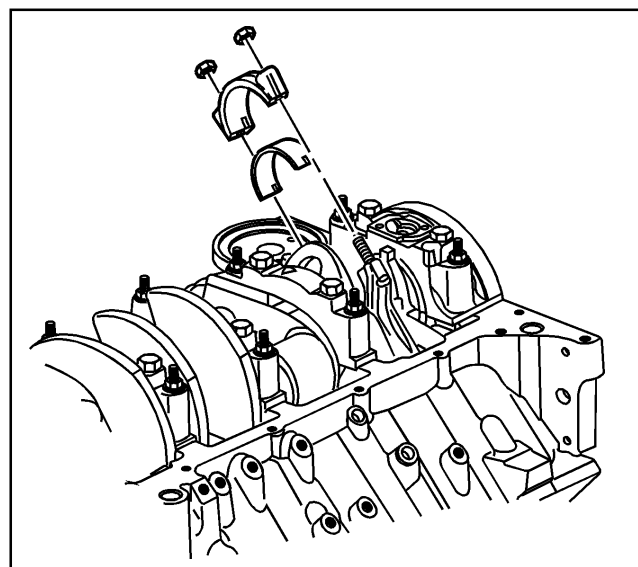

639084

**Notice:** Refer to *Fastener Notice* in Cautions and Notices.

**Important:** When installing the piston/connecting rod assembly, NEW connecting rod nuts must be installed.

10. Install the new connecting rod nuts.

**Tighten**

Tighten the connecting rod nuts to 30 N·m (22 lb ft). Using the J 36660-A, tighten the connecting rod nuts an additional 90 degrees.

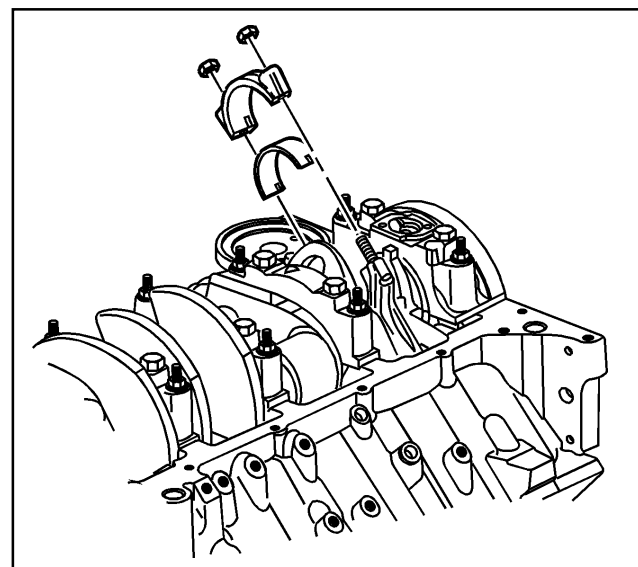

639084

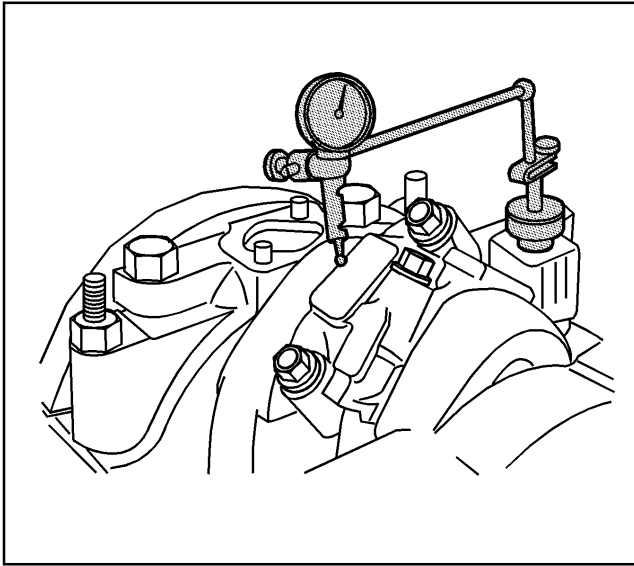

677801

11. Once the piston and connecting rod assemblies have been installed, lightly tap each connecting rod assembly (parallel to the crankpin) in order to make sure that they have side clearance.
12. Use a feeler gauge or a dial indicator to measure the side clearance between the connecting rod caps. The connecting rod side clearance should be 0.384-0.686 mm (0.0151-0.0270 in).

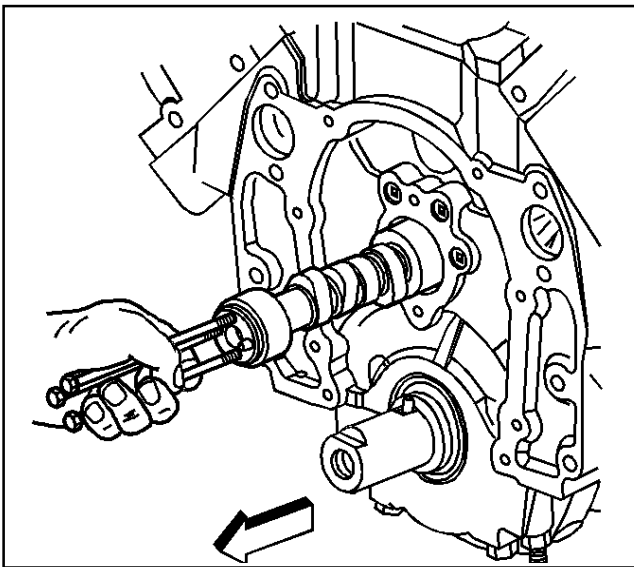

471002

### Camshaft Installation

1. Lubricate the following components with clean engine oil, engine supplement GM P/N 1052367 or equivalent:
  - The camshaft lobes
  - The camshaft bearing journals
  - The camshaft bearings

**Notice:** All camshaft journals are the same diameter, so care must be used in removing or installing the camshaft to avoid damage to the camshaft bearings.

2. Install the three 8-1.25 x 100 mm bolts in the camshaft front bolt holes.
3. Using the bolts as a handle, install the camshaft.
4. Remove the three bolts from the front of the camshaft.

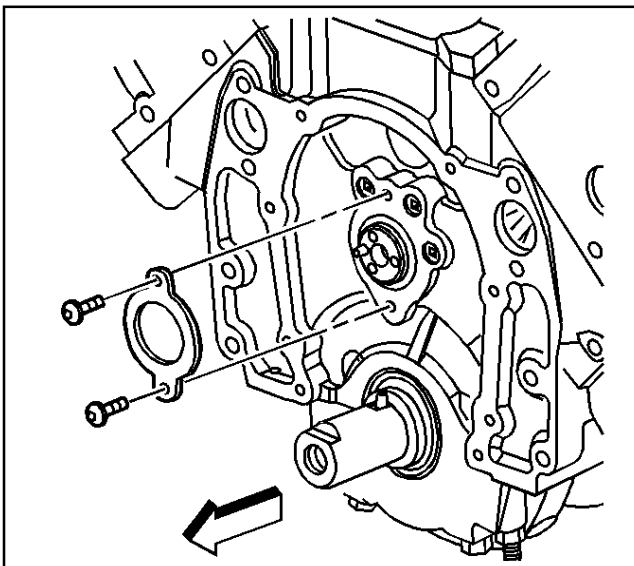

470998

5. Install the camshaft retainer.

**Notice:** Refer to *Fastener Notice* in Cautions and Notices.

6. Install the camshaft retainer bolts.

#### Tighten

Tighten the camshaft retainer bolts to 12 N·m (106 lb in).



### Timing Chain and Sprockets Installation

**Tools Required**

J 22102 Crankshaft Sprocket Installer

1. Use the J 22102 in order to install the crankshaft sprocket.  
Align the keyway of the crankshaft sprocket with the crankshaft pin.
2. Rotate the crankshaft until the crankshaft sprocket alignment mark is in the 12 o'clock position.

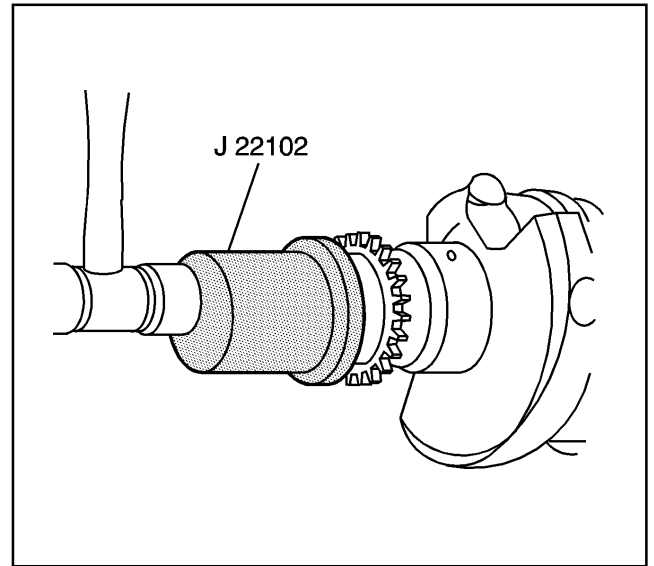

65850

**Important:** Install the camshaft sprocket with the alignment mark in the 6 o'clock position.

**Important:** The sprocket teeth must mesh with the timing chain in order to prevent damage to the camshaft retainer.

**Important:** Do not use a hammer to install the camshaft sprocket onto the camshaft. To do so may dislodge the rear camshaft plug and/or damage the camshaft.

3. Install the camshaft sprocket and timing chain.

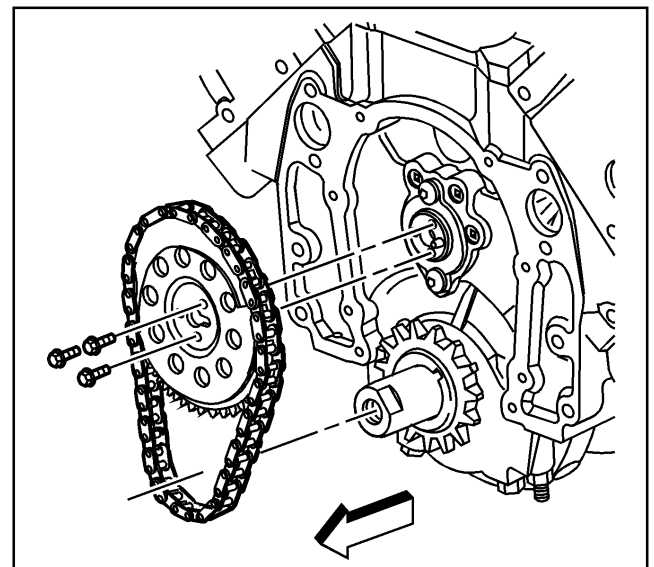

470814

4. Look to ensure that the crankshaft sprocket is aligned at the 12 o'clock position and the camshaft sprocket is aligned at the 6 o'clock position.

**Notice:** Refer to *Fastener Notice* in Cautions and Notices.

5. Install the camshaft sprocket bolts.

**Tighten**

- Tighten the three camshaft sprocket bolts to 30 N·m (22 lb ft).
- Tighten the three camshaft sprocket bolts in a second pass to 30 N·m (22 lb ft).

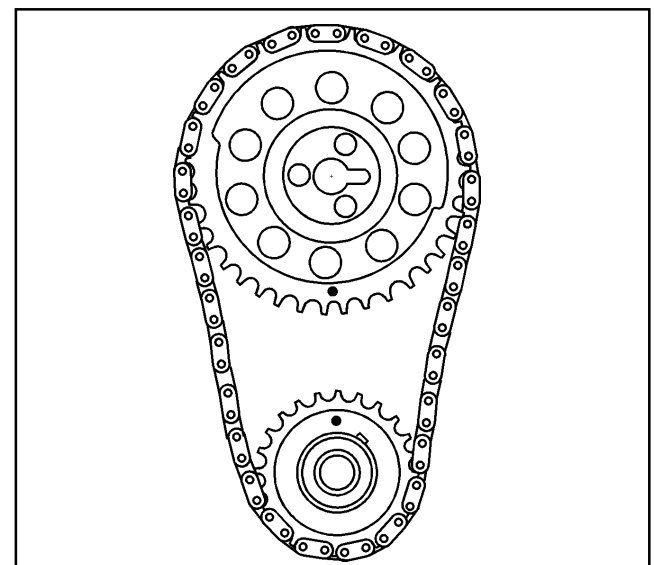

677756

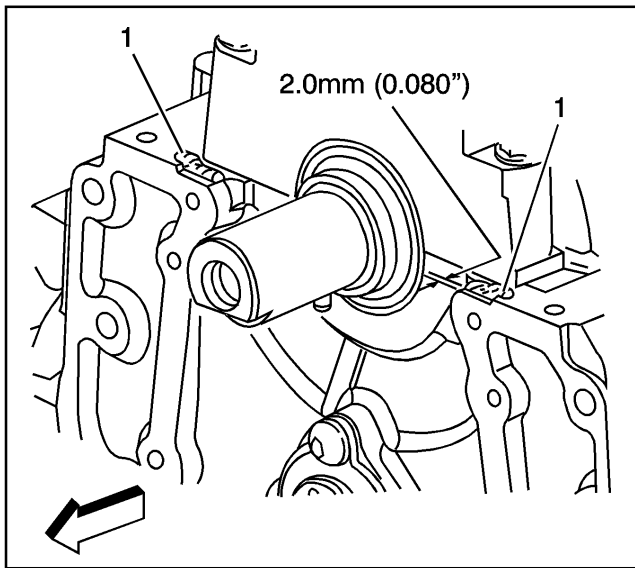

470807

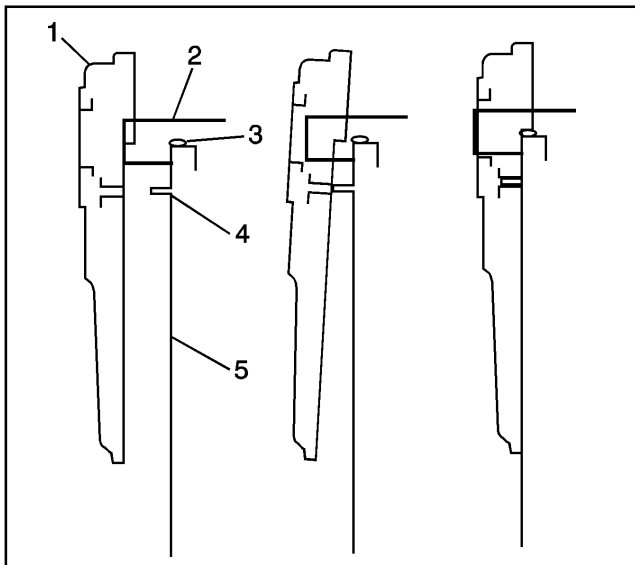

719124

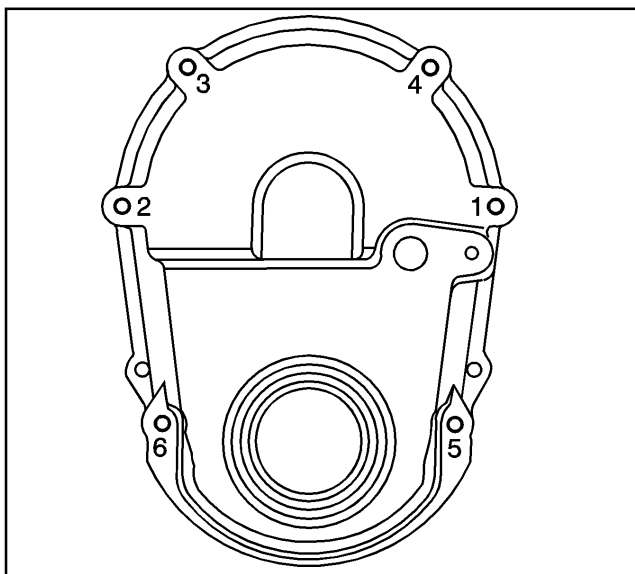

677874

## Engine Front Cover Installation

### Tools Required

*J 42851* Front Cover Oil Seal Installer

1. Install the NEW crankshaft front oil seal using the *J 42851*.
2. Lubricate the sealing surface of the crankshaft front oil seal with clean engine oil.

**Important:** The front cover must be installed and the fasteners tightened while the sealant is still wet to the touch.

3. Apply the sealant GM P/N 12346286 or equivalent in two sealant points (1) on the engine block where the front cover meets the oil pan.

4. Install the engine front cover gasket into the front cover.

**Important:** The following method must be used when installing the engine front cover. Failure to follow the instructions will push the sealant out, which may cause an oil leak.

5. Install the engine front cover.
  - 5.1. Hold the front cover (1) up to the crankshaft (2).
  - 5.2. Lift the front cover (1) while sliding the cover over the crankshaft (2).
  - 5.3. Slide the front cover towards the engine block (5) while keeping the cover raised.
  - 5.4. Lower the cover down over the dowel pin (4), allowing the front cover to rest on the sealant (3).

**Notice:** Refer to *Fastener Notice* in Cautions and Notices.

6. Install the engine front cover bolts.

### Tighten

- Tighten the engine front cover bolts in sequence to 6 N·m (54 lb in) in the first pass.
- Tighten the engine front cover bolts in sequence to 12 N·m (106 lb in) in the second pass.

7. Inspect the camshaft position sensor O-ring for cuts, cracks, tears or damage. Replace the O-ring as needed.
8. Apply a light film of clean engine oil to the camshaft position sensor O-ring.
9. Install the camshaft position sensor.

**Notice:** This bolt is a self-tapping bolt. If installing this bolt into a new component, installation of the bolt may be difficult. Ensure that the bolt is not over-torqued during the initial installation (thread cutting). Failure to limit torque can lead to bolt failure.

10. Install the camshaft position sensor bolt.

**Tighten**

Tighten the camshaft position sensor bolt to 12 N·m (106 lb in).

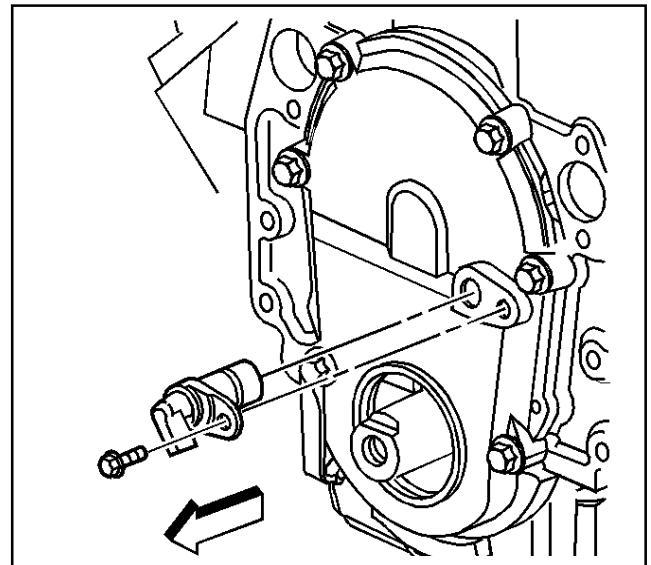

470803

**Oil Pump, Pump Screen and Deflector Installation**

1. Install the crankshaft oil deflector.

**Notice:** Refer to *Fastener Notice* in Cautions and Notices.

2. Install the crankshaft oil deflector nuts.

**Tighten**

Tighten the crankshaft oil deflector nuts to 50 N·m (37 lb ft).

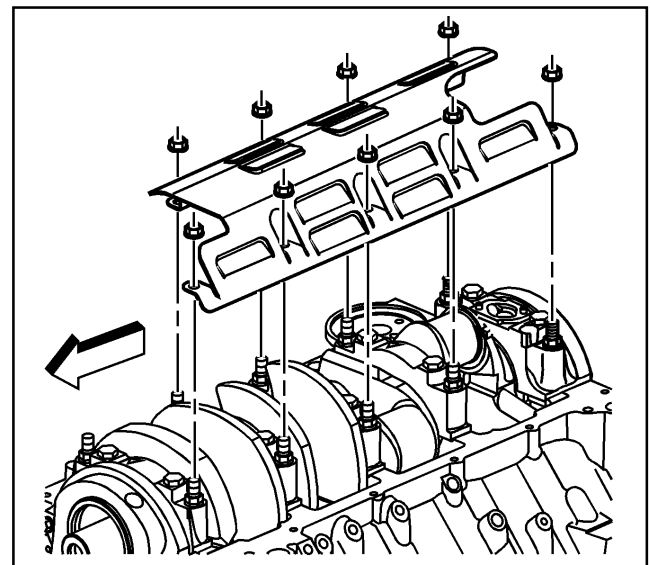

635703

**Important:** During assembly, install a NEW oil pump driveshaft retainer. Slightly heat retainer above room temperature for ease of installation onto the oil pump driveshaft.

3. Assemble the oil pump, driveshaft and a NEW retainer.
4. Install the oil pump assembly.  
Position the oil pump onto the locating pins.
5. Install the bolt attaching the oil pump to the rear crankshaft bearing cap.

**Tighten**

Tighten the oil pump bolt to 75 N·m (55 lb ft).

6. Pour clean engine oil into the oil pump pickup screen.
7. Rotate crankshaft in direction of engine rotation in order to prime the oil pump.

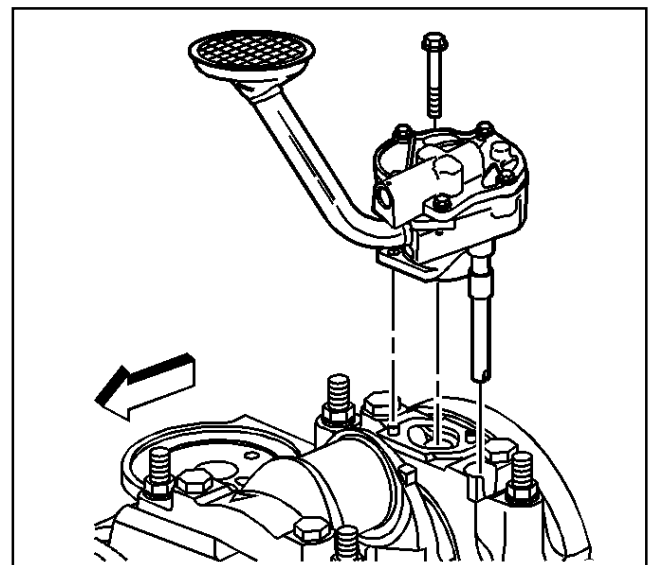

471060

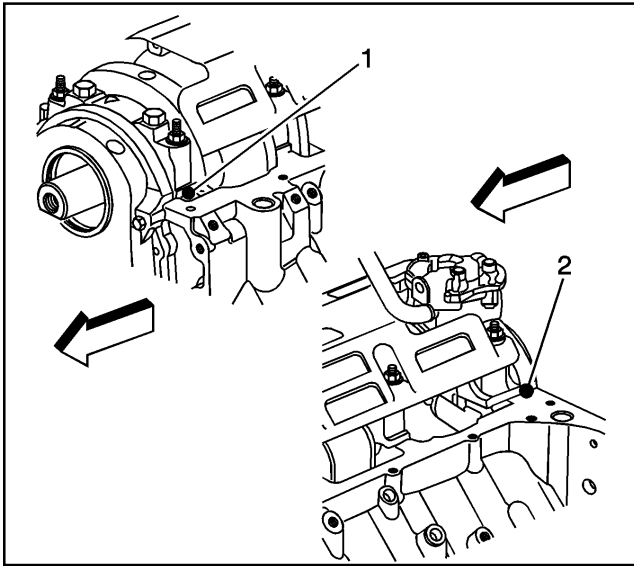

677833

### Oil Pan Installation

**Important:** The oil pan must be installed within five minutes of the sealer being applied or the sealer will begin to cure, causing an inadequate seal.

1. Apply sealant GM P/N 12346286 or equivalent to the side of the front (1) and rear (2) crankshaft bearing caps, on both the left and right sides (four locations total).

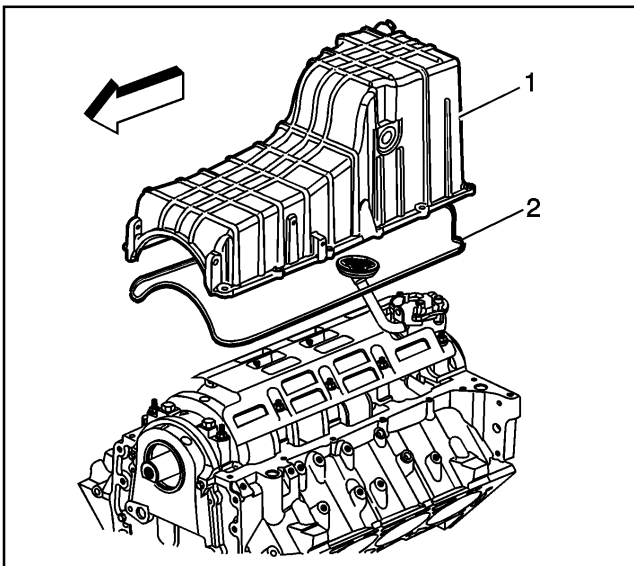

635654

2. Install the new oil pan gasket (2) into the pan groove.
3. Install the oil pan (1).

**Notice:** Refer to *Fastener Notice* in Cautions and Notices.

4. Install the oil pan bolts.
5. Tighten the oil pan bolts in sequence.

**Tighten**

- Tighten the oil pan bolts in sequence to 10 N·m (88 lb in) in a first pass.
- Tighten the oil pan bolts in sequence to 25 N·m (18 lb ft) in a second pass.

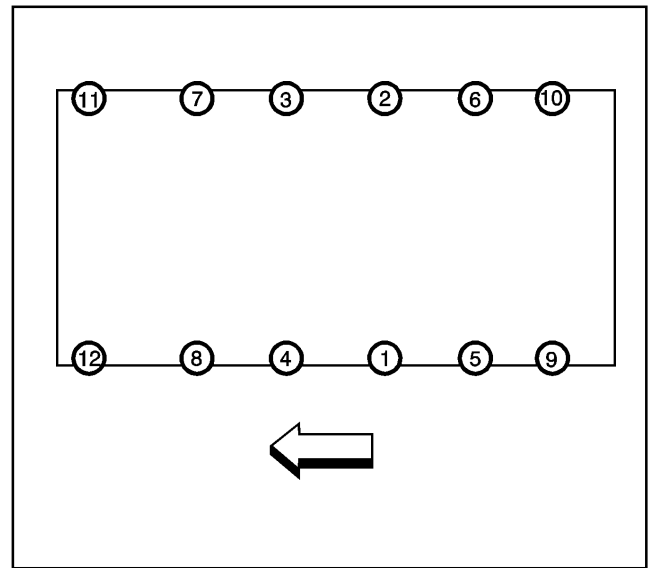

677869

6. Install the oil pan drain plug.

**Tighten**

Tighten the oil pan drain plug to 28 N·m (21 lb ft).

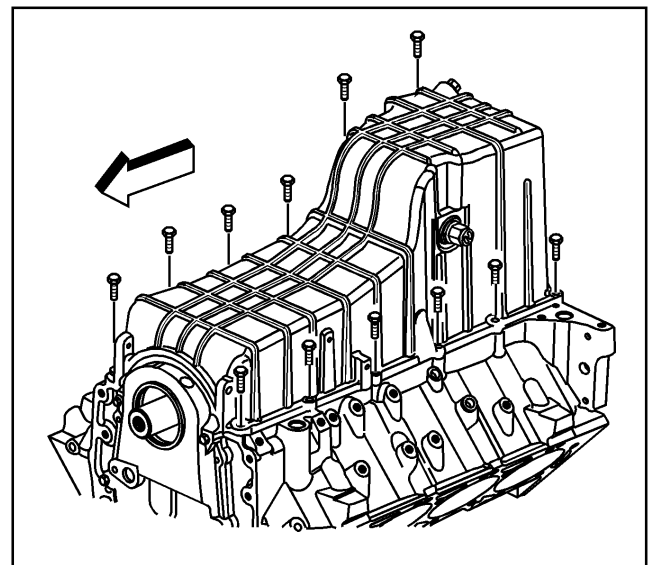

635648

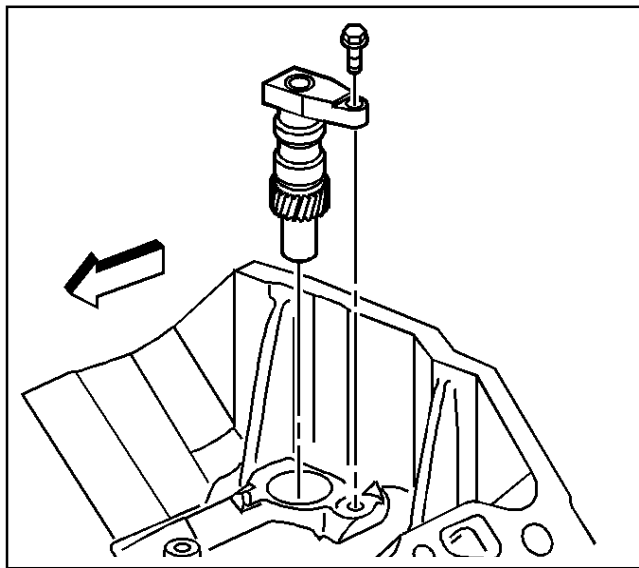

470910

### Oil Pump Drive Installation

1. Apply grease to the oil pump drive gear for ease of assembly.

**Important:** Correct alignment of the oil pump drive and oil pump drive shaft is critical. Make sure both components mate correctly, or engine damage may occur.

2. Line up the oil pump drive gear with the oil pump drive shaft.
3. Install the oil pump drive, making sure that the oil pump drive is fully seated in the engine block.

**Notice:** Refer to *Fastener Notice* in Cautions and Notices.

4. Install the oil pump drive bolt.

#### Tighten

Tighten the oil pump drive bolt to 25 N·m (18 lb ft).

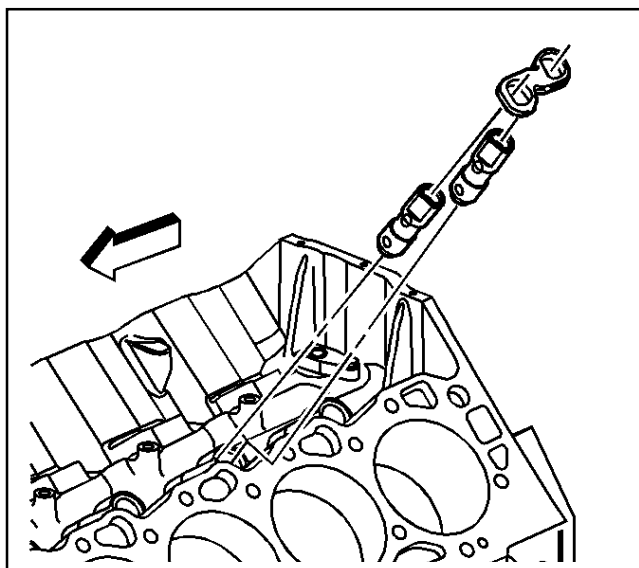

470996

### Valve Lifter Installation

**Important:** If a new camshaft is installed, replace all the valve lifters.

1. Coat the valve lifter rollers with prelude, GM P/N 1052367 or equivalent.

**Important:** If reusing the valve lifters, install in their original locations. The valve lifter guide retainer must contact all of the valve lifter guides. If the valve lifter guide retainer is bent, the valve lifter guide retainer must be replaced.

2. Install the valve lifters.
3. Install the valve lifter guides over the flats on the valve lifters, making sure the rollers of the valve lifters are properly aligned with the camshaft lobes.

4. Install the valve lifter guide retainer.

**Notice:** Refer to *Fastener Notice* in Cautions and Notices.

5. Install the valve lifter guide retainer bolts.

**Tighten**

Tighten the valve lifter guide retainer bolts to 25 N·m (18 lb ft).

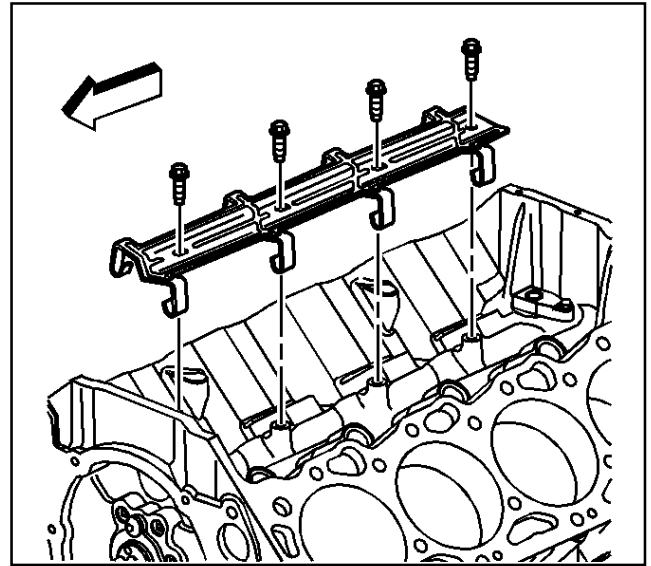

470994

**Cylinder Head Installation - Left**

**Tools Required**

J 36660-A Electronic Torque Angle Meter

**Important:** Make sure the threaded holes in the engine block are clean and not damaged. Do not use sealer on any engines that use a composition type gasket. Align the cylinder head gasket locating mark to face up.

1. Place the cylinder head gasket in position over the cylinder head locating pins.

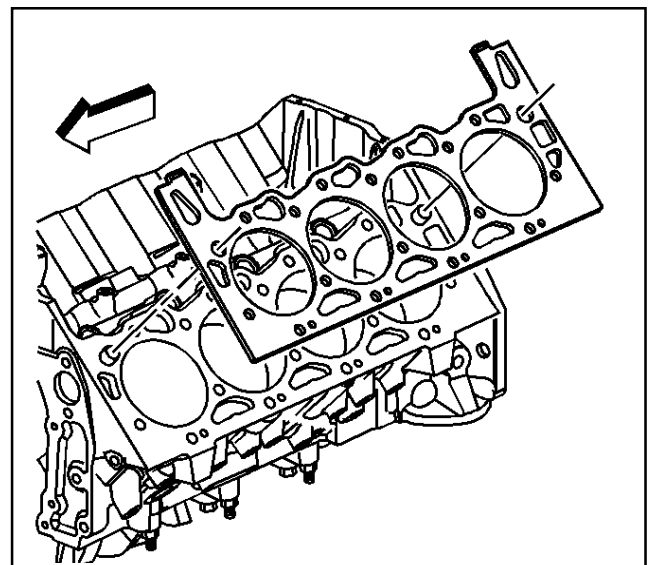

470974

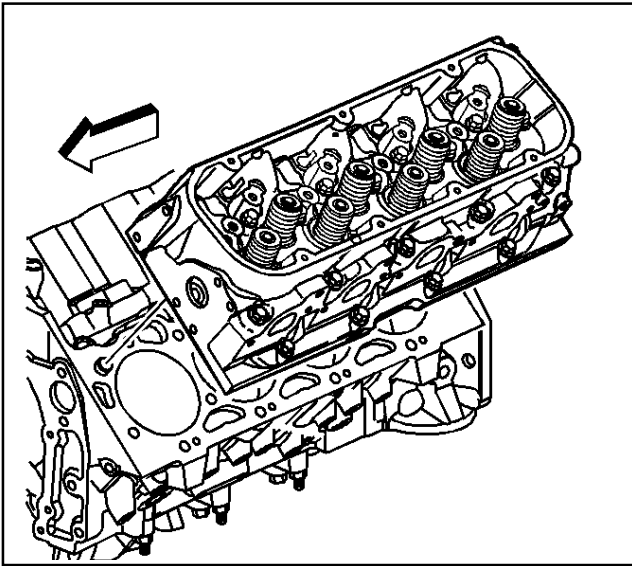

470916

**Important:** Guide the cylinder head carefully into place over the locating pins and the cylinder head gasket.

2. Install the cylinder head to the engine block.

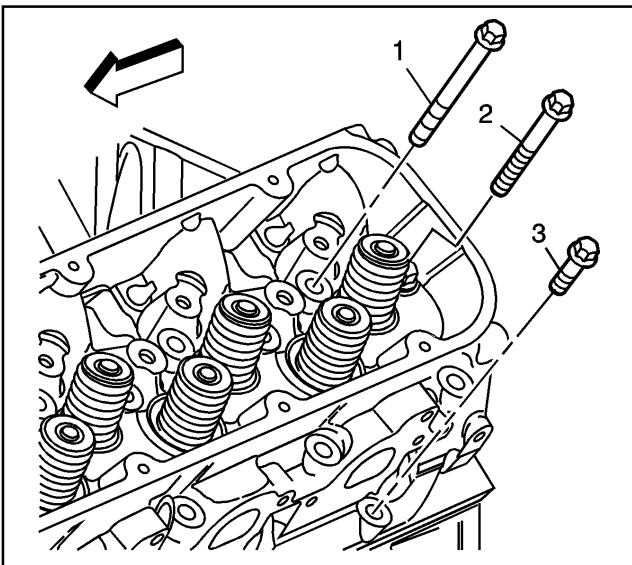

470914

**Notice:** Always use NEW cylinder head bolts when servicing the cylinder head.

Do not reuse the cylinder head bolts, because the bolts may stretch or break causing engine damage.

**Important:** The sealer must be applied to a minimum of eight threads starting at the point of the cylinder head bolt.

3. If not pre-applied to the new cylinder head bolts, apply sealer GM P/N 12346004 or equivalent to the cylinder head bolts. Refer to *Use of RTV and Anaerobic Sealer*.

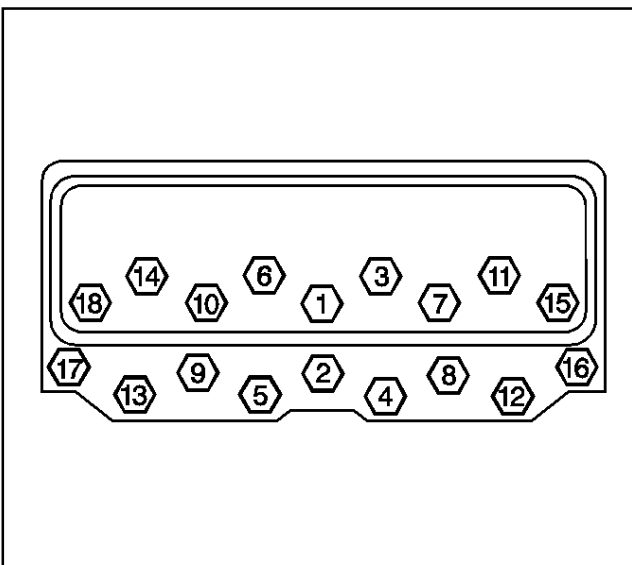

470987

**Notice:** Refer to *Fastener Notice* in Cautions and Notices.

**Important:** The long bolts are used in locations 1, 2, 3, 6, 7, 8, 9, 10, 11, 14, 16 and 17. The medium length bolts are used in locations 15 and 18. The short bolts are used in locations 4, 5, 12 and 13.

4. Install the cylinder head bolts.

#### Tighten

- 4.1. Tighten the bolts a first pass in sequence to 30 N·m (22 lb ft).
- 4.2. Retighten the bolts in a second pass in sequence to 30 N·m (22 lb ft), then an additional 120 degrees using the J 36660-A.
- 4.3. Using the J 36660-A, tighten the bolts (1, 2, 3, 6, 7, 8, 9, 10, 11, 14, 16, 17) an additional 60 degrees, bolts (15 and 18) an additional 45 degrees and bolts (4, 5, 12, 13) an additional 30 degrees a final pass in sequence.



### Cylinder Head Installation - Right

**Tools Required**

J 36660-A Electronic Torque Angle Meter

**Important:** Make sure the threaded holes in the engine block are clean and not damaged. Do not use sealer on any engines that use a composition type gasket. Align the cylinder head gasket locating mark to face up.

1. Place the cylinder head gasket in position over the cylinder head locating pins.

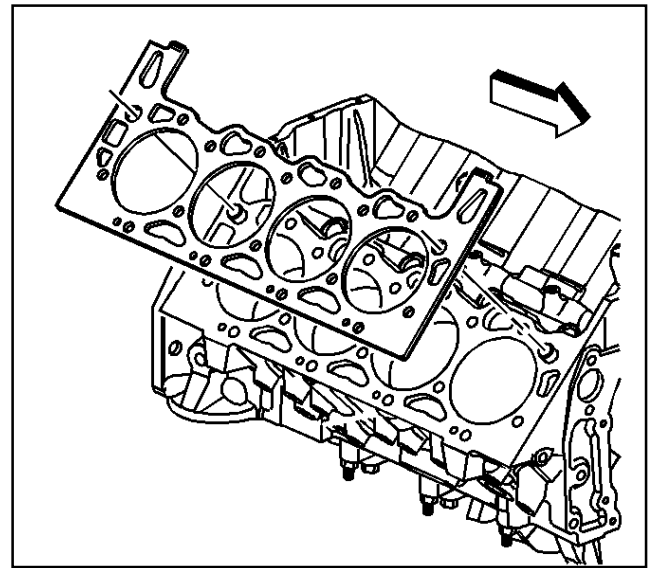

470992

**Important:** Guide the cylinder head carefully into place over the locating pins and the cylinder head gasket.

2. Install the cylinder head to the engine block.

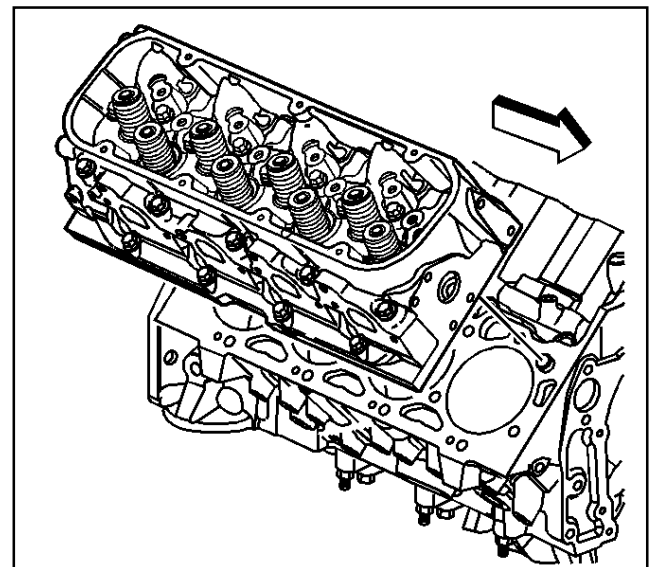

470991

**Notice:** Always use NEW cylinder head bolts when servicing the cylinder head.

Do not reuse the cylinder head bolts, because the bolts may stretch or break causing engine damage.

**Important:** The sealer must be applied to a minimum of eight threads starting at the point of the cylinder head bolt.

3. If not pre-applied to the new cylinder head bolts, apply sealer GM P/N 12346004 or equivalent to the cylinder head bolts. Refer to *Use of RTV and Anaerobic Sealer*.

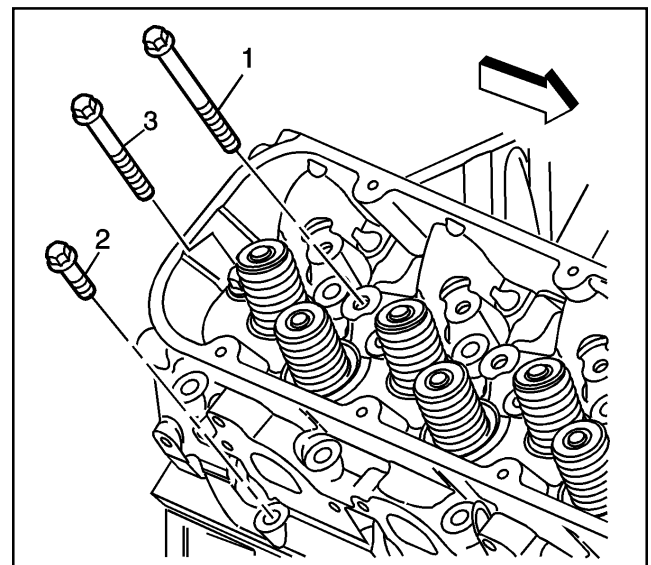

470989

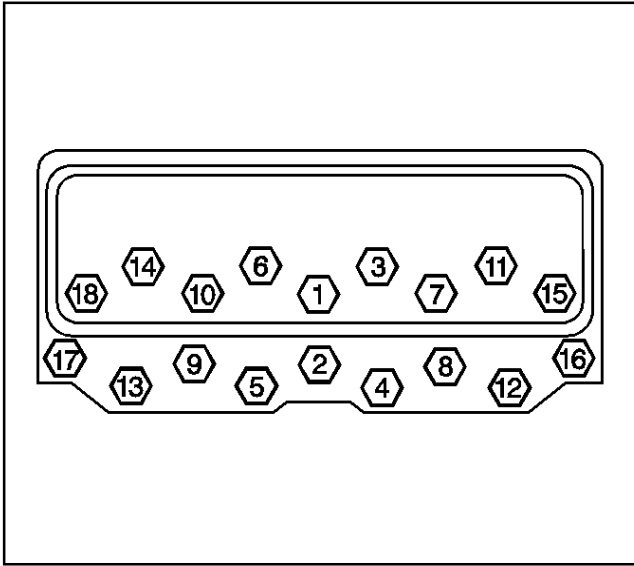

470987

**Notice:** Refer to *Fastener Notice* in Cautions and Notices.

**Important:** The long bolts are used in locations 1, 2, 3, 6, 7, 8, 9, 10, 11, 14, 16 and 17. The medium length bolts are used in locations 15 and 18. The short bolts are used in locations 4, 5, 12 and 13.

4. Install the cylinder head bolts.

#### Tighten

- 4.1. Tighten the bolts a first pass in sequence to 30 N·m (22 lb ft).
- 4.2. Retighten the bolts in a second pass in sequence to 30 N·m (22 lb ft), then an additional 120 degrees using the J 36660-A.
- 4.3. Using the J 36660-A, tighten the bolts (1, 2, 3, 6, 7, 8, 9, 10, 11, 14, 16, 17) an additional 60 degrees, bolts (15 and 18) an additional 45 degrees and bolts (4, 5, 12, 13) an additional 30 degrees a final pass in sequence.

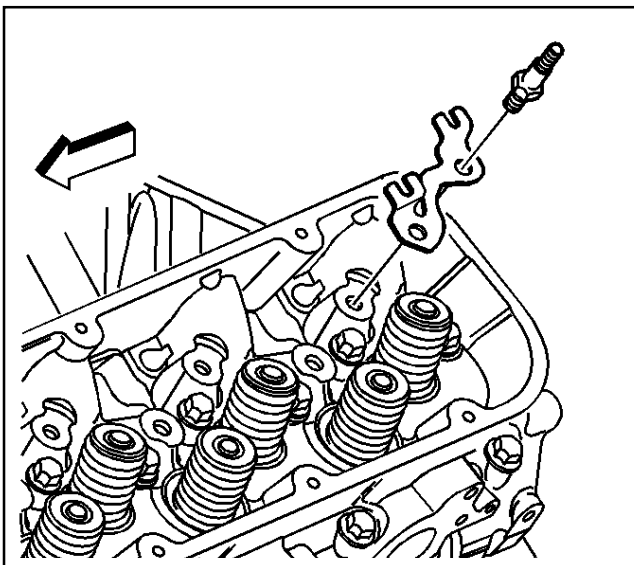

470906

### Valve Rocker Arm and Push Rod Installation

**Important:** Be sure to keep parts in order. Parts must be put back from where they were removed.

1. Apply sealer GM P/N 12346004 or equivalent to the valve rocker arm stud-to-cylinder head threads.

**Notice:** Refer to *Fastener Notice* in Cautions and Notices.

2. Install the push rod guides and valve rocker arm studs onto the cylinder head.

#### Tighten

Tighten the valve rocker arm studs to 50 N·m (37 lb ft).

**Important:** The 8.1L engine uses different length intake and exhaust valve push rods.

The exhaust valve push rods (2) are longer than the intake valve push rods (1).

3. Install the valve push rods.

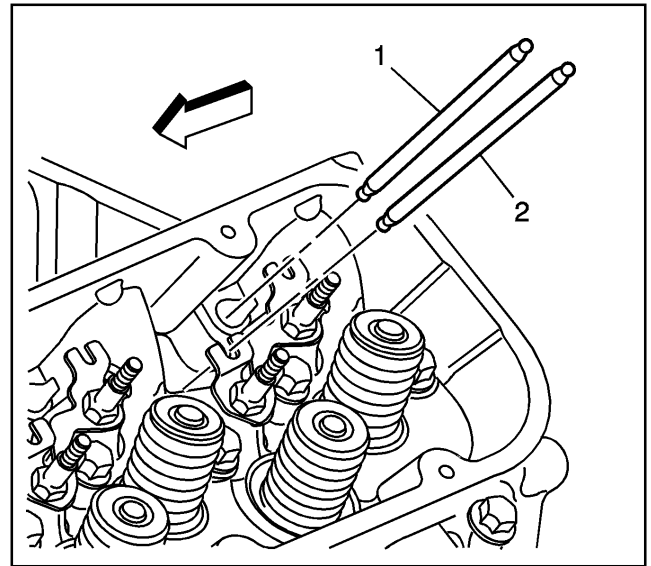

470903

4. Coat the valve rocker arm and valve rocker arm ball bearing surfaces with prelube GM P/N 1052367 or equivalent.
5. Install the valve rocker arms, the valve rocker arm balls and the valve rocker arm nuts.

### Tighten

Tighten the valve rocker arm nuts slowly, to 25 N·m (18 lb ft), while guiding the tips of the rocker arms over the tips of the halves.

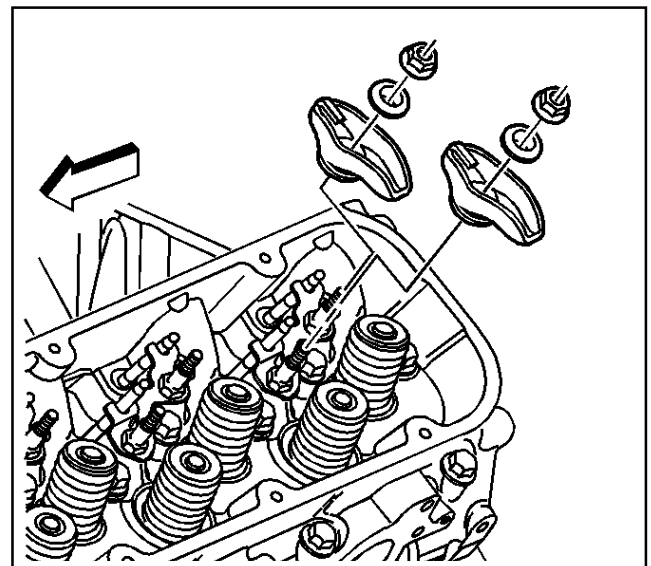

470899

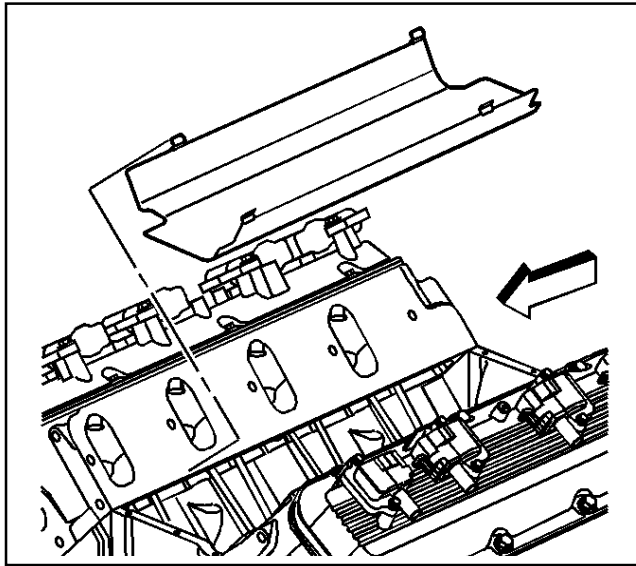

470786

### Intake Manifold Installation

1. Install the splash shield.

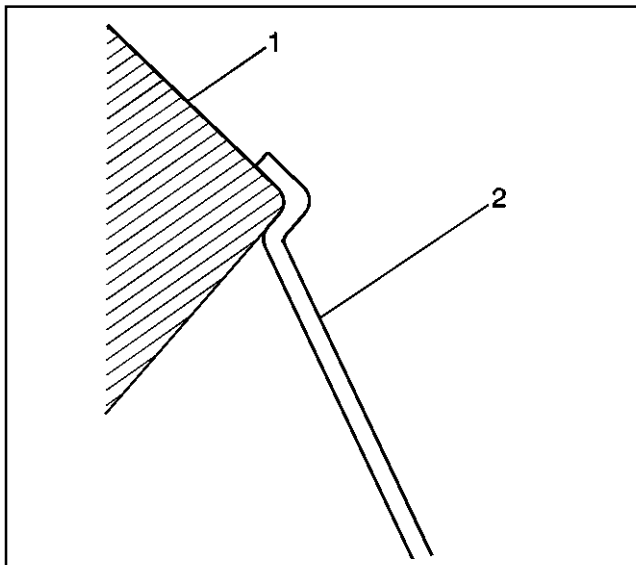

413867

2. Ensure the splash shield (2) snap fits between the cylinder heads (1).

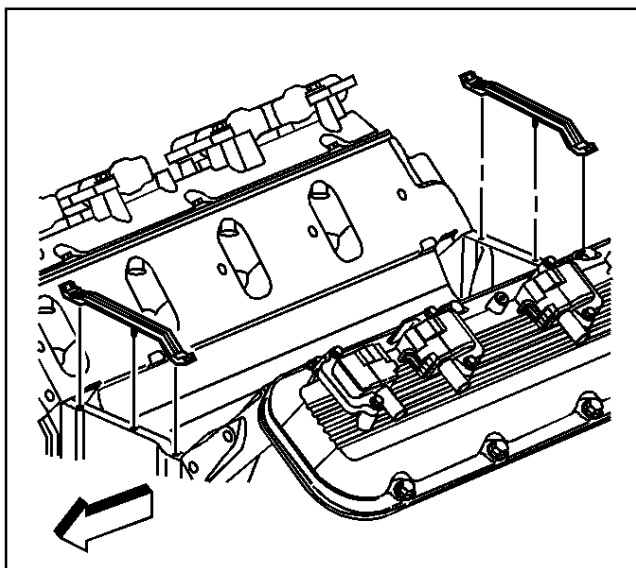

470783

3. Install the new intake manifold end seals.

4. Install the new intake manifold side gaskets onto the cylinder heads.

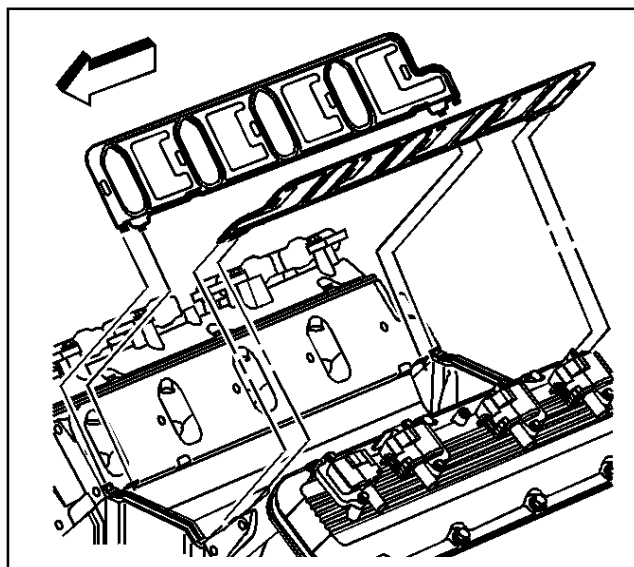

470779

5. Ensure the intake manifold gasket tabs align with the hole in the head gasket.
6. Ensure the intake manifold gasket tabs align with the slot in the lower intake manifold seals.

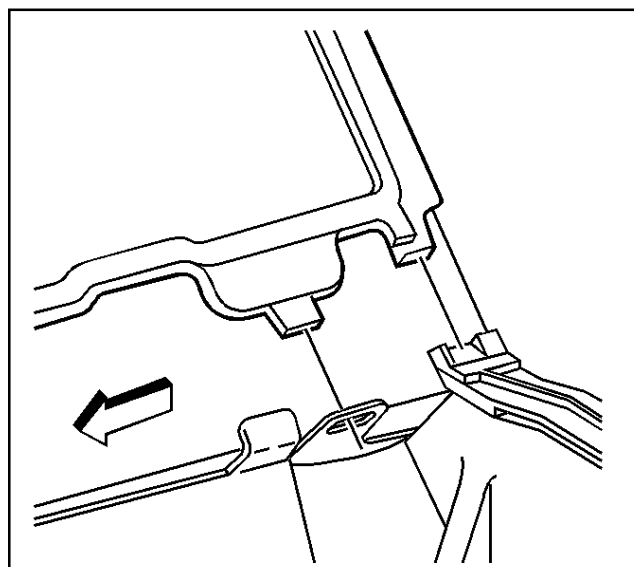

470778

7. Install the intake manifold onto the engine block.

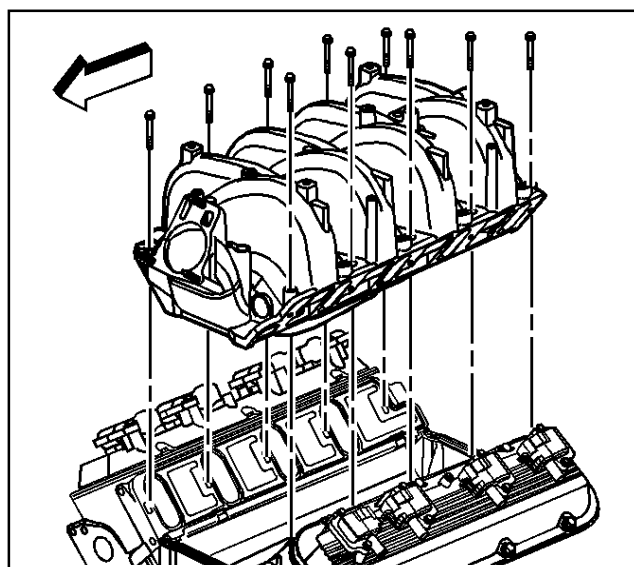

470775

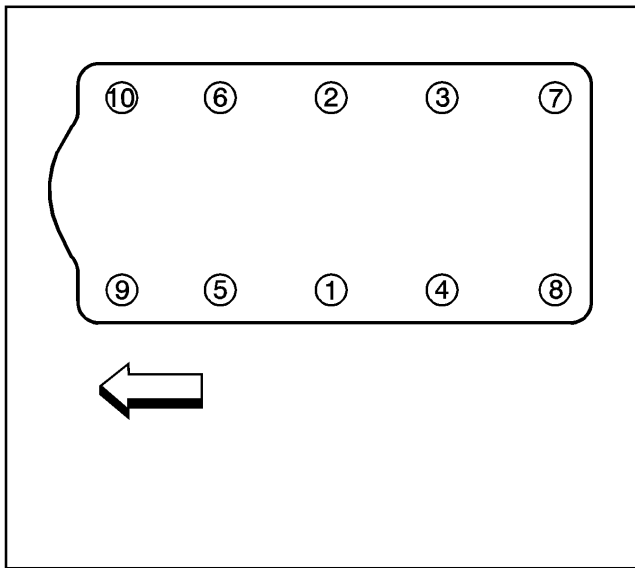

640010

**Important:** The entire intake manifold tightening sequence must be followed exactly, or an oil leak resulting in engine damage may occur. Ensure the intake manifold is tightened without allowing the intake manifold to shift.

**Notice:** Refer to *Fastener Notice* in Cautions and Notices.

**Important:** The entire intake manifold tightening sequence must be promptly completed due to the anaerobic thread adhesive. The final pass of the tightening sequence must be completed before the adhesive starts to cure, or false torque readings and ineffective thread locking may result.

8. Apply thread adhesive GM P/N 12345382 or equivalent to a minimum of eight threads of the intake manifold bolts.
9. Install the intake manifold bolts.
10. Tighten the intake manifold bolts in sequence, using four passes.

#### Tighten

- Tighten the intake manifold bolts in sequence to 2 N·m (18 lb in) on the first pass.
- Tighten the intake manifold bolts in sequence to 2 N·m (18 lb in) on the second pass. Inspect the intake manifold joints for signs of intake manifold shifting. Correct as required.
- Tighten the intake manifold bolts in sequence to 10 N·m (88 lb in) on the third pass.
- Tighten the intake manifold bolts in sequence to 12 N·m (106 lb in) on the final pass.

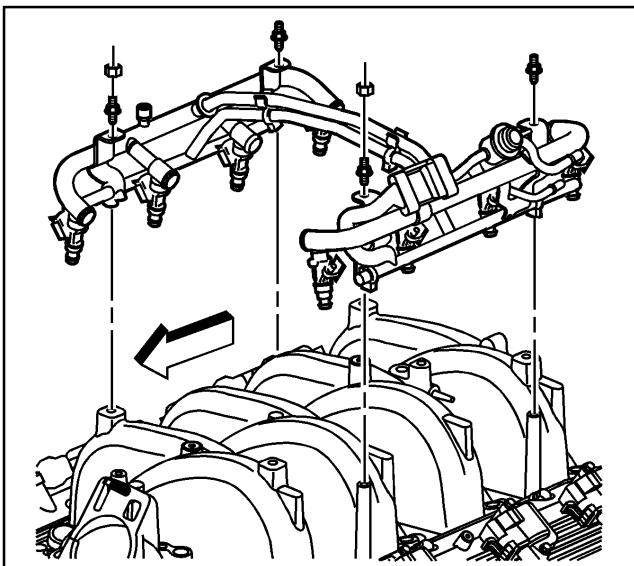

470774

**Important:** Lubricate the injector O-ring seals with clean engine oil and install onto the spray tip end of each injector.

11. Install the fuel injection fuel rail.
12. Install the fuel injection fuel rail studs and/or bolts.

#### Tighten

Tighten the fuel injection fuel rail studs and/or bolts to 12 N·m (106 lb in).

13. Install the fuel pressure regulator vacuum hose.

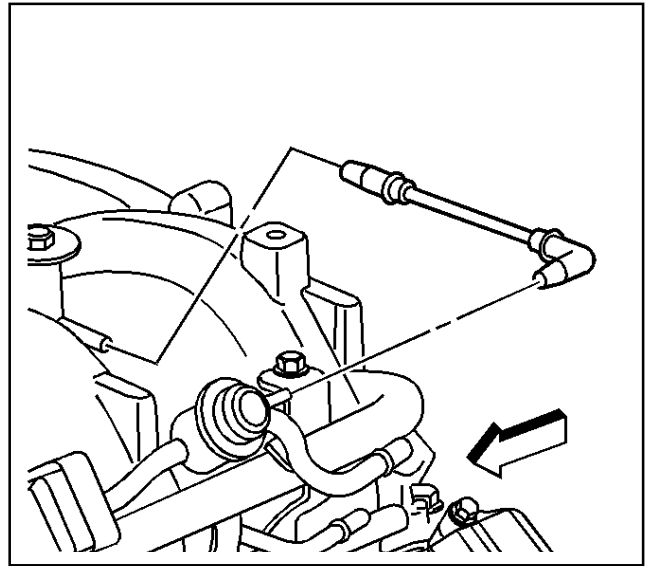

470770

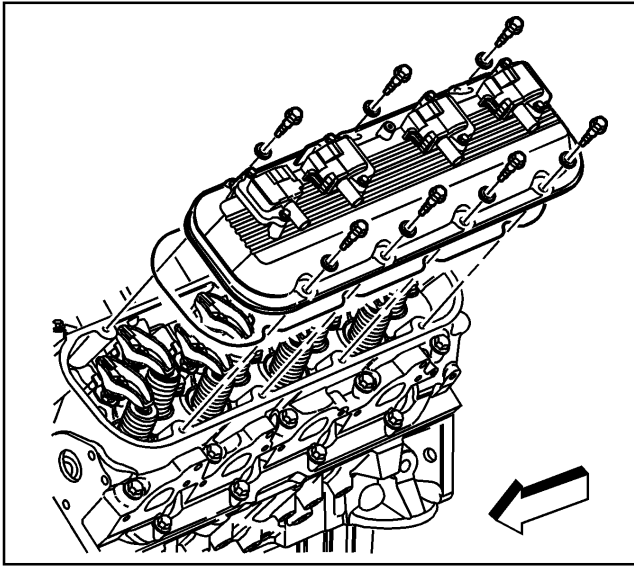

470890

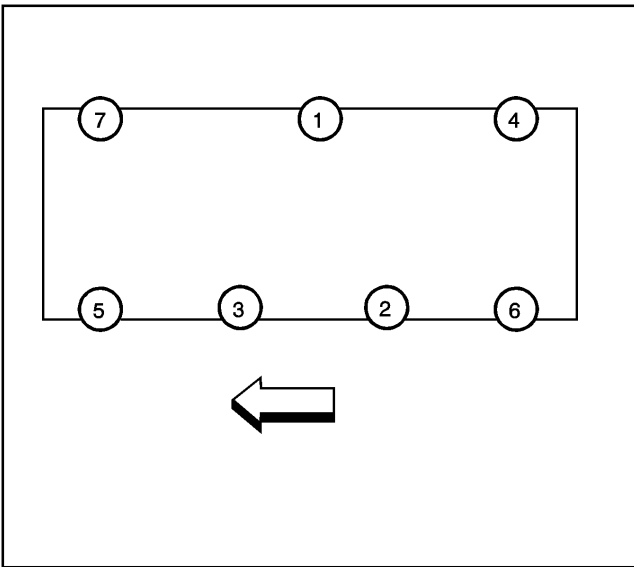

677858

### Valve Rocker Arm Cover Installation - Left

**Important:** If the valve rocker arm cover gasket was removed from the valve rocker arm cover, install a NEW valve rocker arm cover gasket.

1. Install the valve rocker arm cover with gasket.
2. Install the valve rocker arm cover bolts.

**Notice:** Refer to *Fastener Notice* in Cautions and Notices.

3. Tighten the valve rocker arm cover bolts in sequence using two passes.

#### Tighten

- Tighten the valve rocker arm cover bolts in sequence to 6 N·m (54 lb in) on the first pass.
- Tighten the valve rocker arm cover bolts in sequence to 12 N·m (106 lb in) on the final pass.



**Valve Rocker Arm Cover Installation - Right**

**Important:** If the valve rocker arm cover gasket was removed from the valve rocker arm cover, install a NEW valve rocker arm cover gasket.

1. Install the valve rocker arm cover with gasket.
2. Install the valve rocker arm cover bolts.

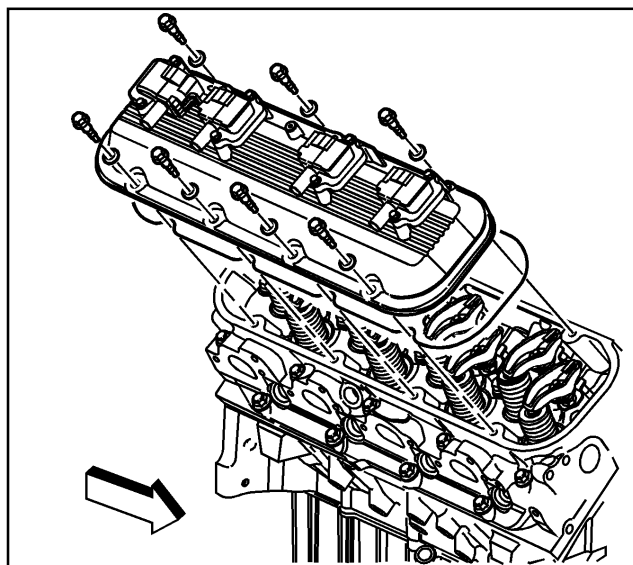

470897

**Notice:** Refer to *Fastener Notice* in Cautions and Notices.

3. Tighten the valve rocker arm cover bolts in sequence using two passes.

**Tighten**

- Tighten the valve rocker arm cover bolts in sequence to 6 N·m (54 lb in) on the first pass.
- Tighten the valve rocker arm cover bolts in sequence to 12 N·m (106 lb in) on the final pass.

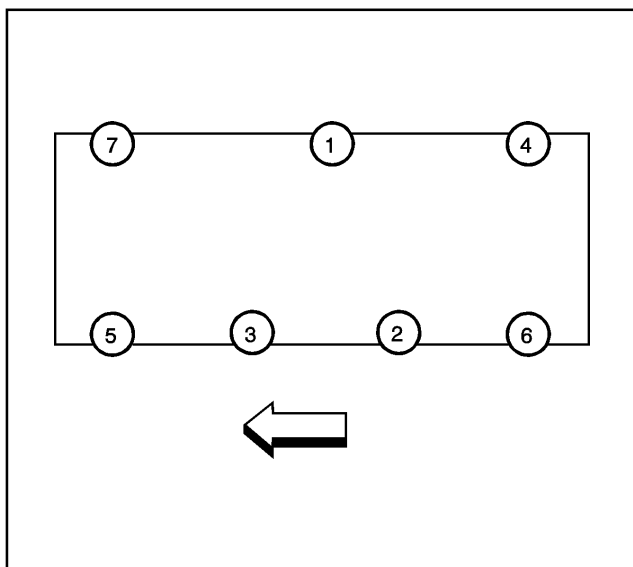

677858

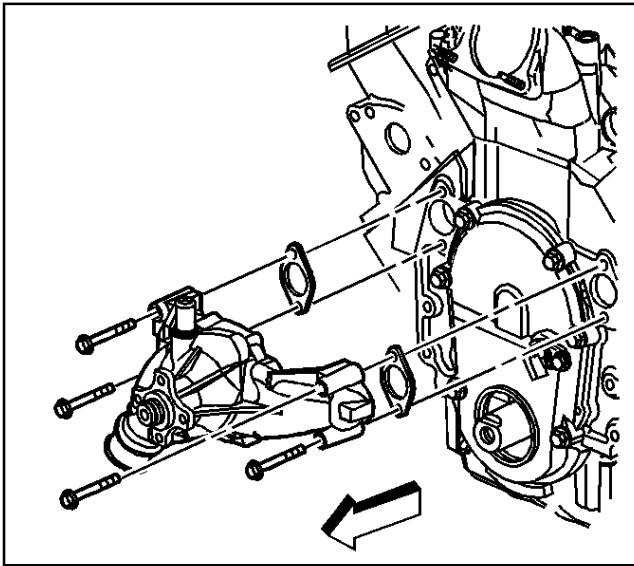

470792

### Water Pump Installation

1. Place the water pump gaskets and the water pump into position.

**Notice:** Refer to *Fastener Notice* in Cautions and Notices.

2. Install the water pump bolts.

#### Tighten

Tighten the water pump bolts to 50 N·m (37 lb ft).

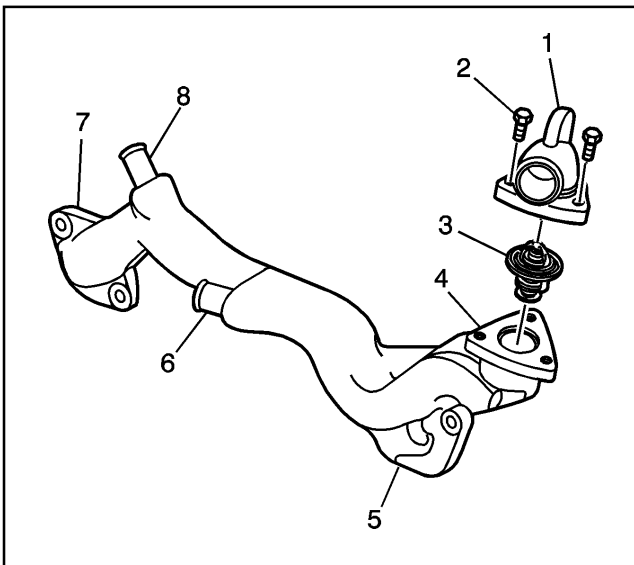

635643

### Water Crossover Installation

#### Tools Required

*J 41240* Fan Clutch Wrench

**Notice:** Refer to *Fastener Notice* in Cautions and Notices.

1. Install the thermostat with the seal into the water crossover.
2. Install the water outlet.
3. Install the water outlet bolts.

#### Tighten

Tighten the water outlet bolts to 30 N·m (22 lb ft).

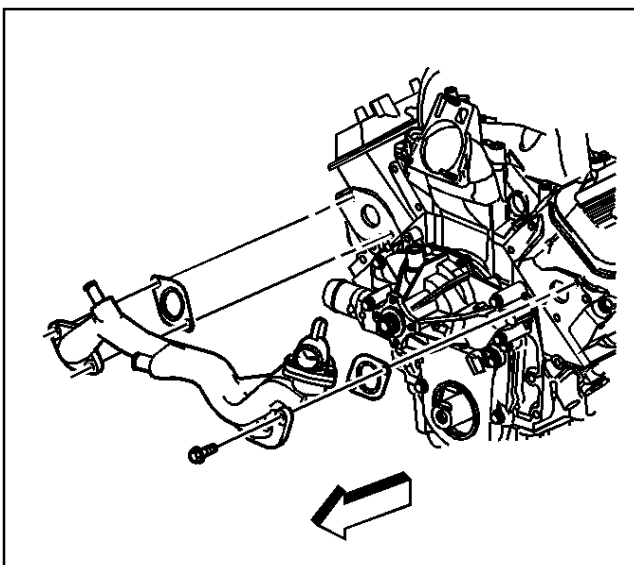

470698

4. Place the water crossover gaskets and the water crossover in position.
5. Install the water crossover bolts.

#### Tighten

Tighten the water crossover bolts to 50 N·m (37 lb ft).

6. Install the thermostat bypass hose clamps onto the thermostat bypass hose.
7. Install the thermostat bypass hose.

**Important:** Properly position the bypass hose clamps to avoid water pump pulley interference.

8. Position the thermostat bypass hose clamps.

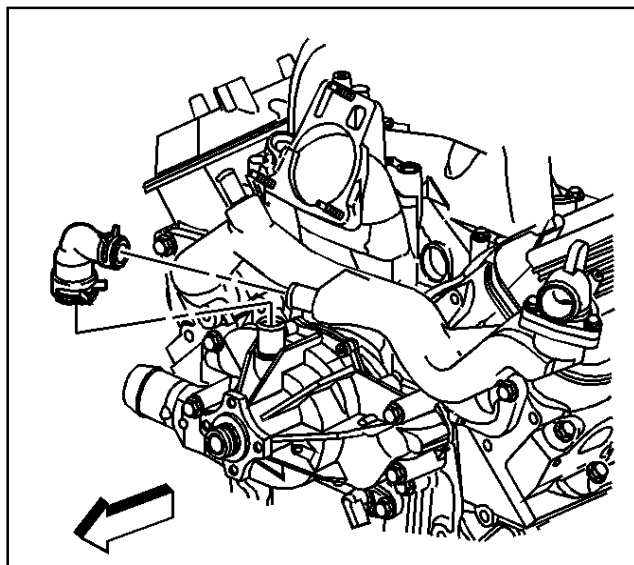

470692

9. Install the drive belt tensioner.
10. Install the drive belt tensioner bolts.

### Tighten

Tighten the drive belt tensioner bolts to 50 N·m (37 lb ft).

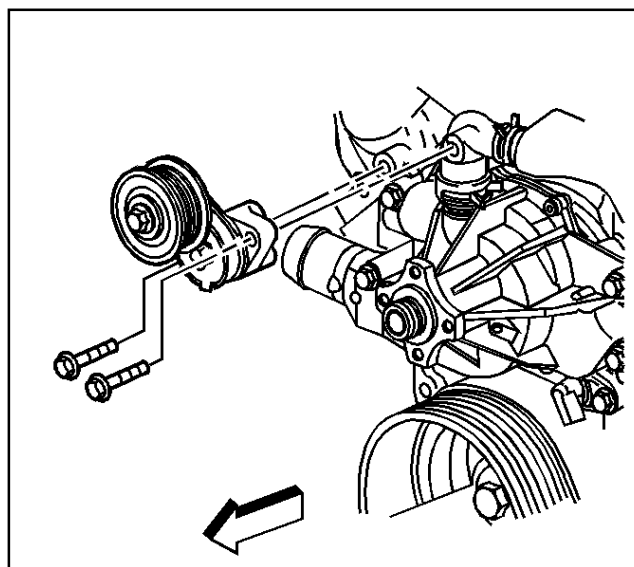

470789

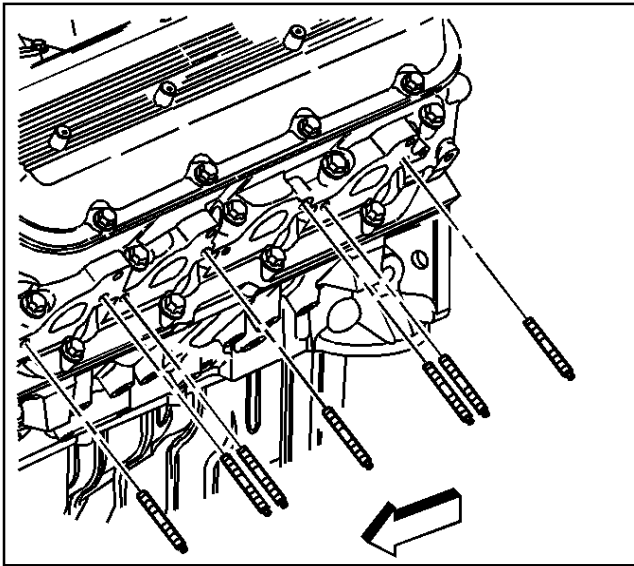

470683

### Exhaust Manifold Installation - Left

**Notice:** Refer to *Fastener Notice* in Cautions and Notices.

1. Install the exhaust manifold studs into the cylinder head (if necessary).

#### Tighten

Tighten the exhaust manifold studs to 20 N·m (15 lb ft).

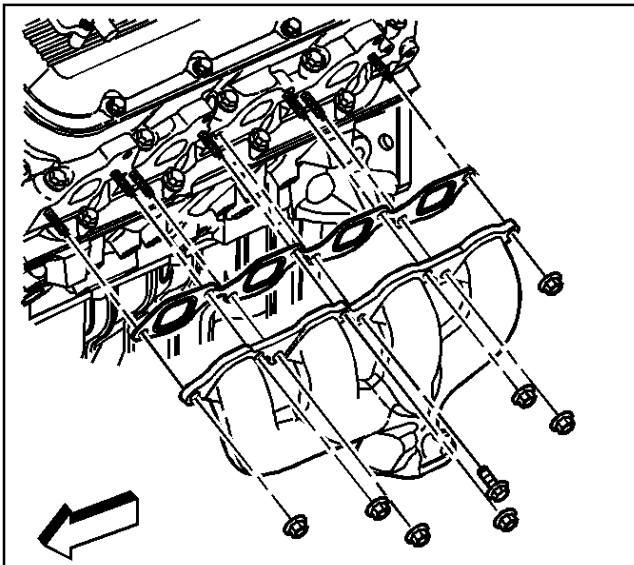

470686

2. Install the NEW left exhaust manifold gasket.
3. Install the left exhaust manifold.
4. Install the left exhaust manifold nuts and center bolt.

#### Tighten

- 4.1. Tighten the left exhaust manifold center bolt to 35 N·m (26 lb ft).
- 4.2. Tighten the left exhaust manifold nuts to 16 N·m (12 lb ft).

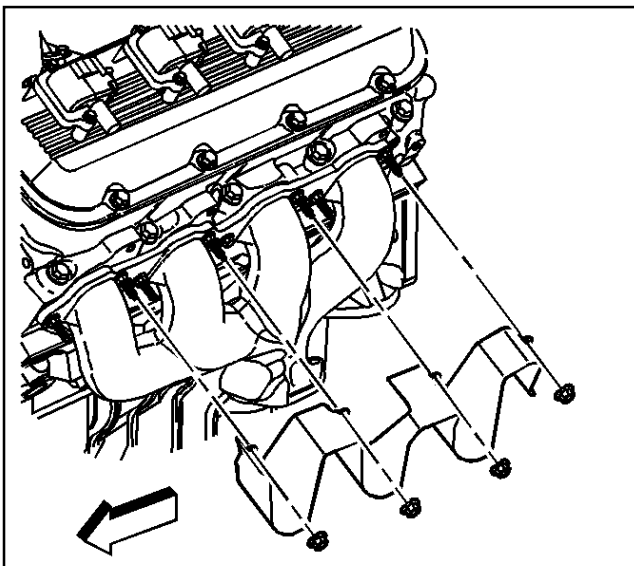

470678

5. Install the left exhaust manifold heat shield.
6. Install the left exhaust manifold heat shield nuts.

#### Tighten

Tighten the left exhaust manifold heat shield nuts to 25 N·m (18 lb ft).

7. Install the left spark plugs.

**Tighten**

Tighten the left spark plugs to 20 N·m (15 lb ft).

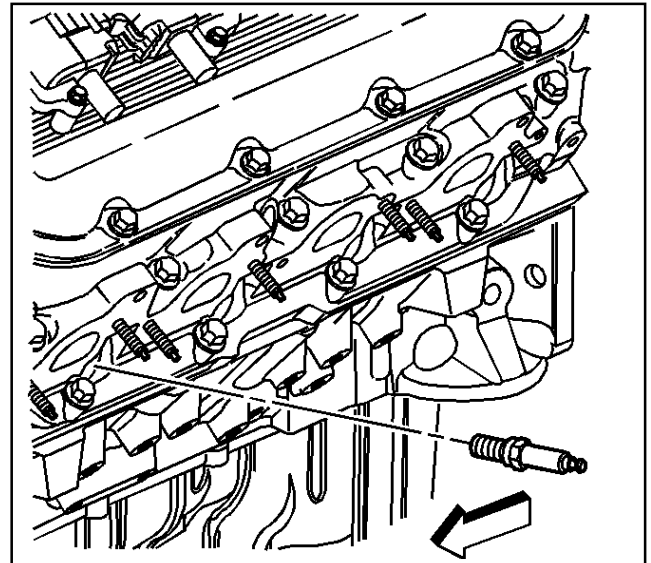

470690

**Important:** Fully install the spark plug wire by pushing on the exposed end of the spark plug boot. Do not push the spark plug wire on the spark plug by using the metal heat shield.

8. Install the left spark plug wires to the spark plugs and ignition coils.

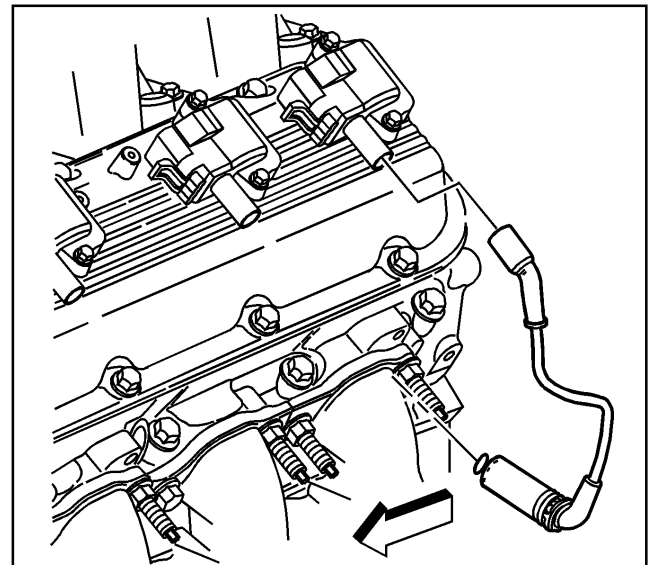

470666

9. Install the ignition coil wiring harness.
10. Connect the ignition coil wiring harness to the ignition coils.
11. Install the ignition coil wiring harness retainer bolts.

**Tighten**

Tighten the ignition coil wiring harness retainer bolts to 12 N·m (106 lb in).

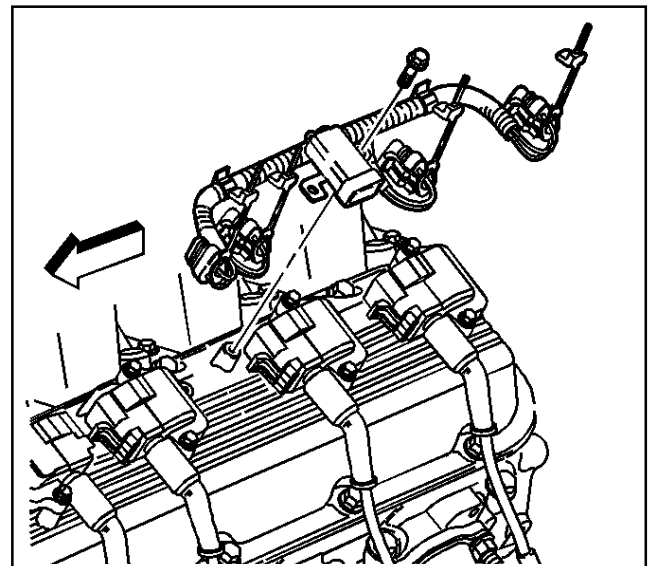

470659

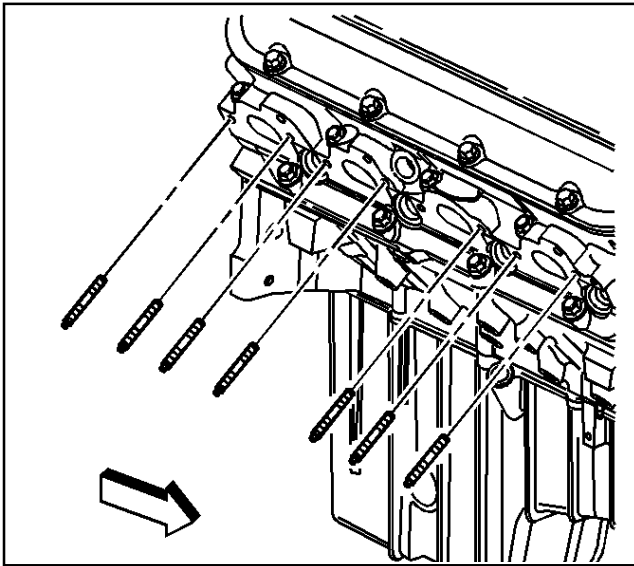

470723

## Exhaust Manifold Installation - Right

**Notice:** Refer to *Fastener Notice* in Cautions and Notices.

1. Install the exhaust manifold studs into the cylinder head (if necessary).

### Tighten

Tighten the exhaust manifold studs to 20 N·m (15 lb ft).

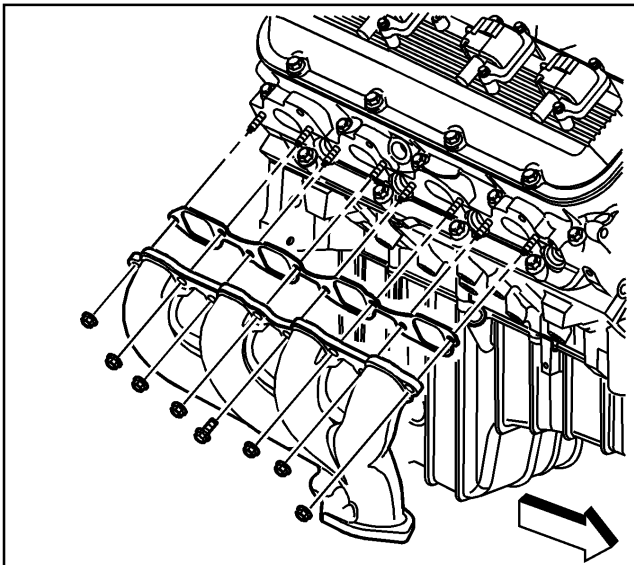

470725

2. Install the NEW right exhaust manifold gasket.
3. Install the right exhaust manifold.
4. Install the right exhaust manifold nuts and center bolt.

### Tighten

- 4.1. Tighten the right exhaust manifold center bolt to 35 N·m (26 lb ft).
- 4.2. Tighten the right exhaust manifold nuts to 16 N·m (12 lb ft).

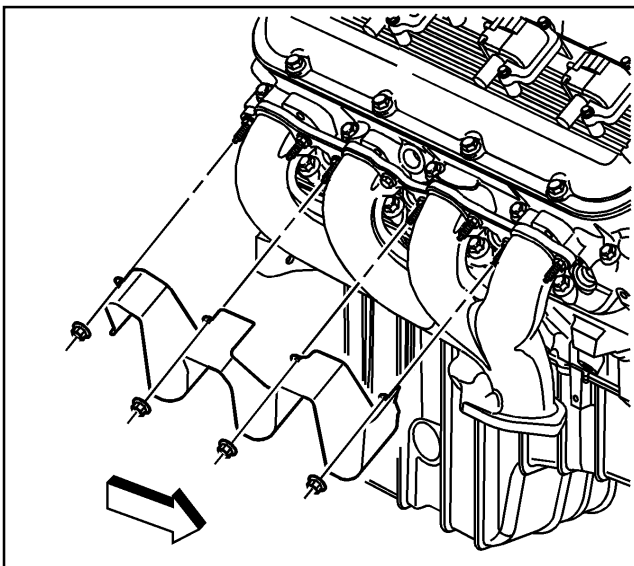

470708

5. Install the right exhaust manifold heat shield.
6. Install the right exhaust manifold heat shield nuts.

### Tighten

Tighten the right exhaust manifold heat shield nuts to 25 N·m (18 lb ft).

7. Install the right spark plugs.

**Tighten**

Tighten the right spark plugs to 20 N·m (15 lb ft).

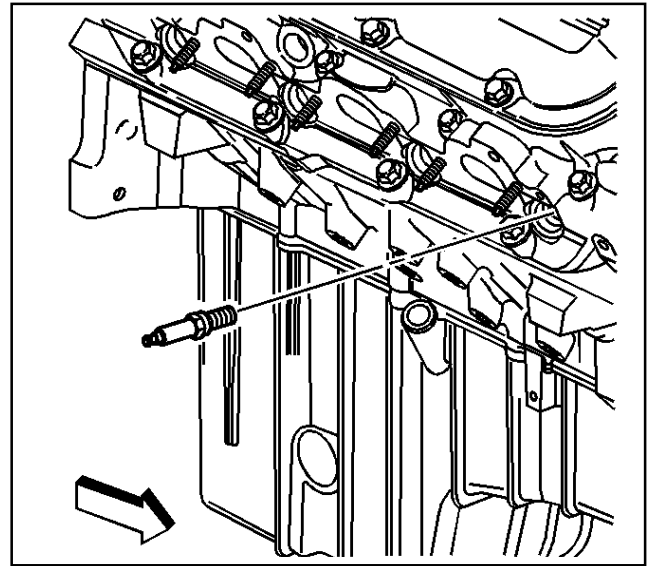

470727

**Important:** Fully install the spark plug wire by pushing on the exposed end of the spark plug boot. Do not push the spark plug wire on to the spark plug by using the metal heat shield.

8. Install the right spark plug wires to the spark plugs and ignition coils.

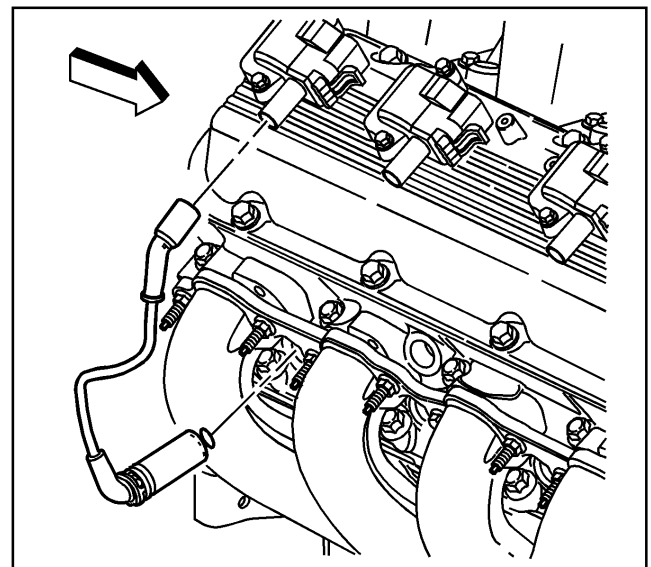

470704

9. Install the exhaust gas recirculation (EGR) pipe and NEW EGR pipe gaskets (if applicable).
10. Install the EGR pipe nuts to the right exhaust manifold (if applicable).

**Tighten**

Tighten the EGR pipe nuts to 30 N·m (22 lb ft).

11. Install the EGR pipe bolts to the EGR adapter plate (if applicable).

**Tighten**

Tighten the EGR pipe bolts to 30 N·m (22 lb ft).

12. Install the EGR pipe bracket bolt.

**Tighten**

Tighten the EGR pipe bracket bolt to 50 N·m (37 lb ft).

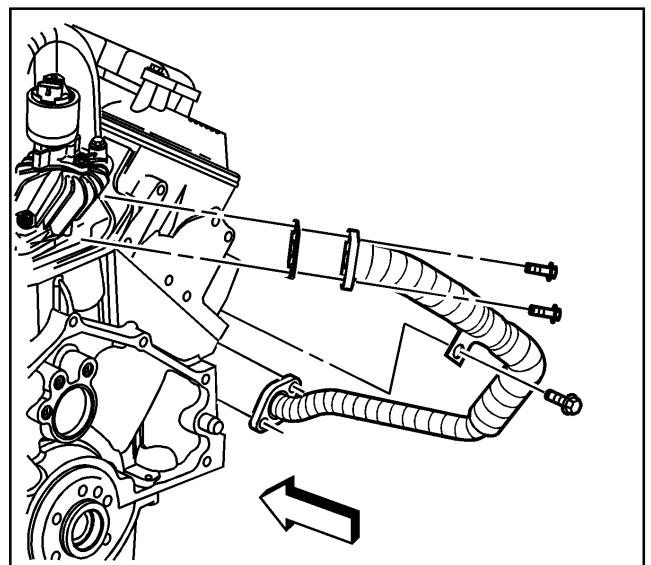

470737

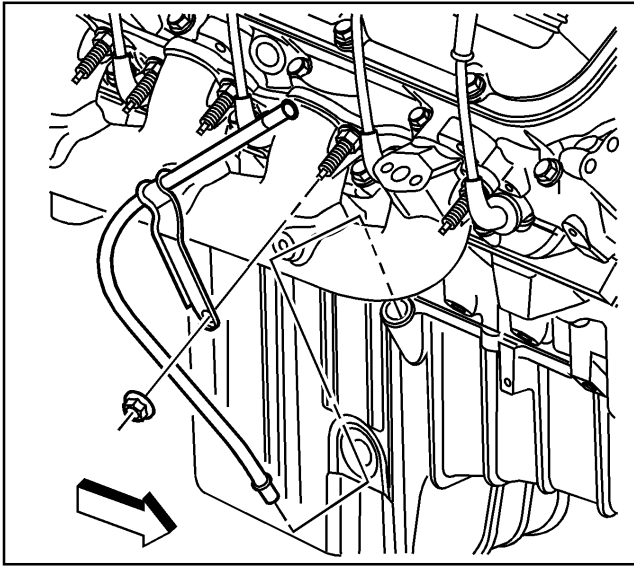

470630

### Oil Level Indicator and Tube Installation

1. Install a NEW O-ring seal onto the oil level indicator tube.
2. Install the oil level indicator tube into the oil pan.
3. Install the oil level indicator tube bracket to the exhaust manifold stud.

**Notice:** Refer to *Fastener Notice* in Cautions and Notices.

4. Install the oil level indicator tube bracket nut to the exhaust manifold stud.

#### Tighten

Tighten the oil level indicator tube bracket nut to 25 N·m (18 lb ft).

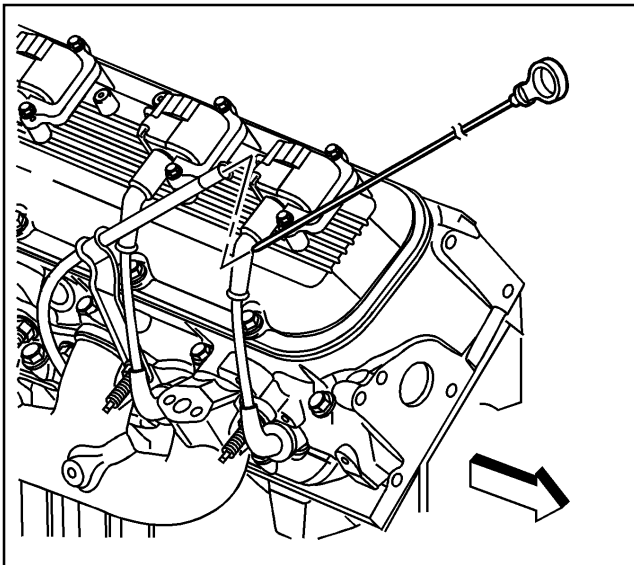

470627

5. Install the oil level indicator into the oil level indicator tube.



**Clutch Pilot Bearing Installation (C/K/ C3500HD)**

**Caution:** *Wear safety glasses in order to avoid eye damage.*

1. Install the NEW clutch pilot bearing.

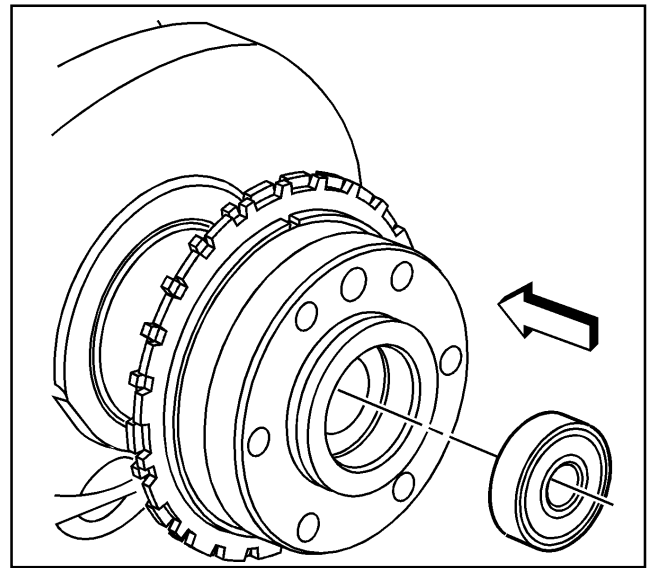

470617

**Important:** Make sure the bearing is installed parallel to the rear of the crankshaft.

2. Measure to ensure the proper installation depth is obtained.

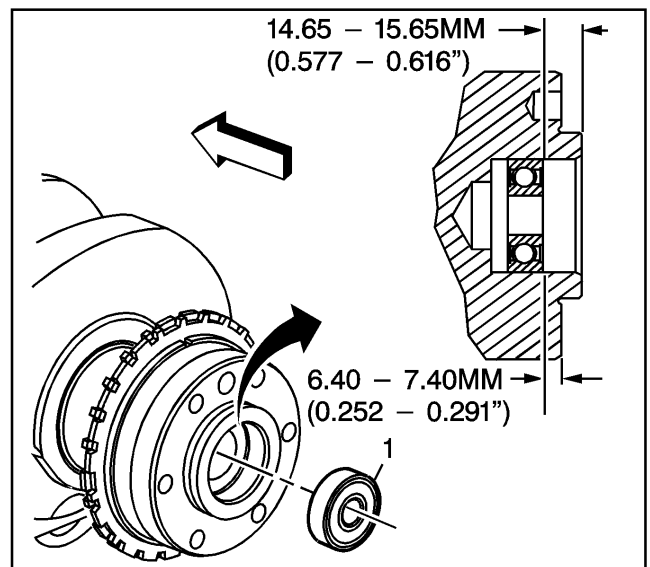

470620

**Clutch Pilot Bearing Installation (Medium Duty)**

**Caution:** *Wear safety glasses in order to avoid eye damage.*

**Important:** Install the bearing from the crankshaft side of the engine flywheel.

1. Install the NEW clutch pilot bearing (1) flush with the surface of the crankshaft flange bore (2).
2. Ensure the proper installation is obtained.

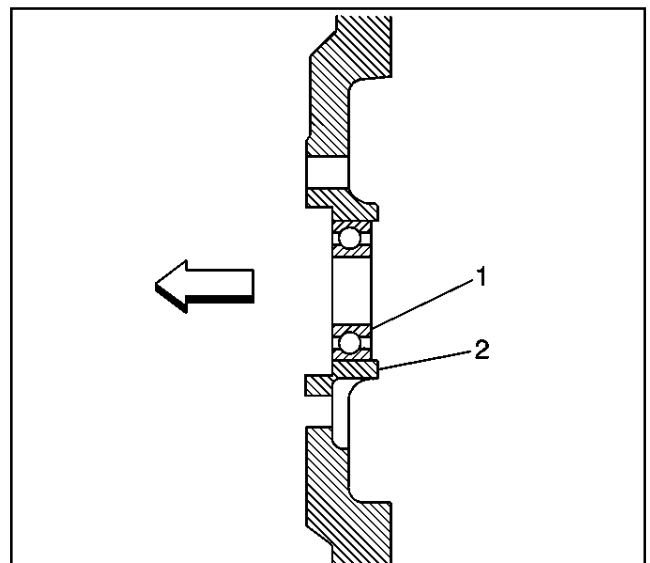

375107

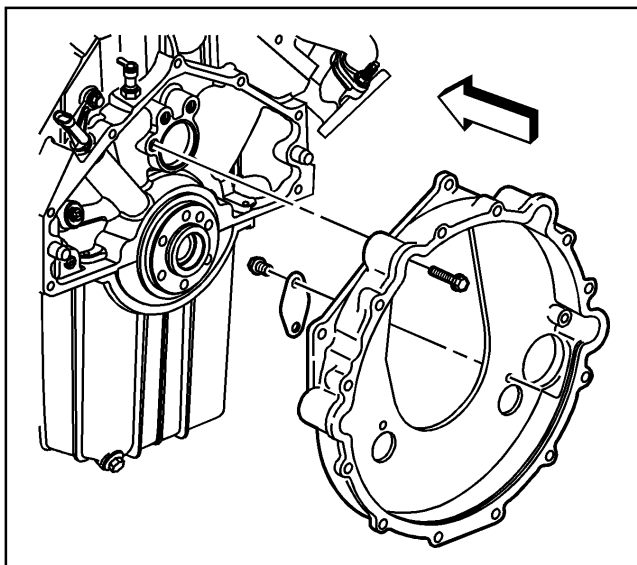

470599

### Engine Flywheel Housing Installation (Medium Duty with AT)

1. Install the transmission converter covers.
2. Install the transmission converter cover bolts.

#### Tighten

Tighten the transmission converter cover bolts to 12 N·m (106 lb in).

3. Install the engine flywheel housing.

**Notice:** Refer to *Fastener Notice* in Cautions and Notices.

4. Install the engine flywheel housing bolts.

#### Tighten

Tighten the engine flywheel housing bolts to 67 N·m (49 lb ft).

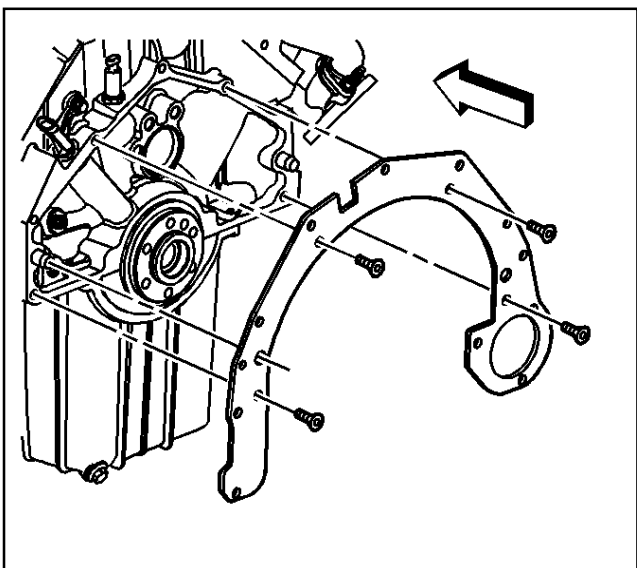

470612

### Engine Flywheel Housing Installation (Medium Duty with MT)

1. Install the engine flywheel housing.

**Notice:** Refer to *Fastener Notice* in Cautions and Notices.

2. Install the engine flywheel housing bolts.

#### Tighten

Tighten the engine flywheel housing bolts to 60 N·m (44 lb ft).

**Engine Flywheel Installation (C/K/G/C3500HD with AT)**

1. Install the engine flywheel.

**Notice:** Refer to *Fastener Notice* in Cautions and Notices.

2. Install the engine flywheel bolts.

**Tighten**

- 2.1. Tighten the engine flywheel bolts to 80 N·m (59 lb ft) on the first pass.
- 2.2. Tighten the engine flywheel bolts to 100 N·m (74 lb ft) on the final pass.

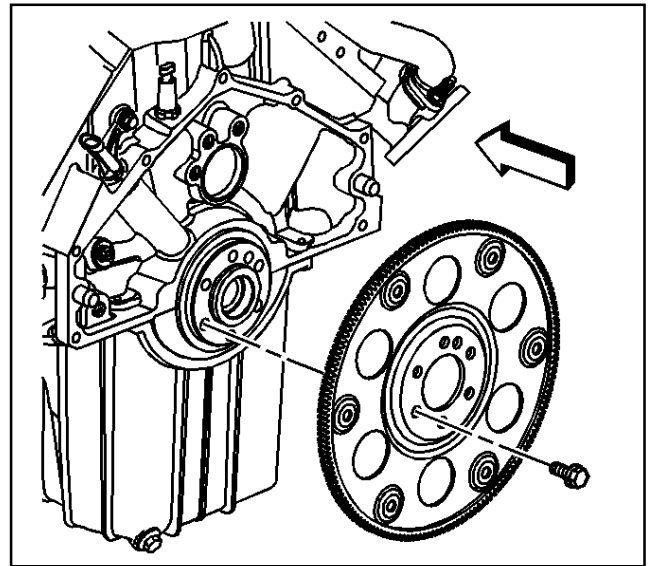

470572

**Engine Flywheel Installation (C/K with MT)**

1. Install the engine flywheel.

**Notice:** Refer to *Fastener Notice* in Cautions and Notices.

2. Install the engine flywheel bolts.

**Tighten**

- 2.1. Tighten the engine flywheel bolts to 80 N·m (59 lb ft) on the first pass.
- 2.2. Tighten the engine flywheel bolts to 100 N·m (74 lb ft) on the final pass.

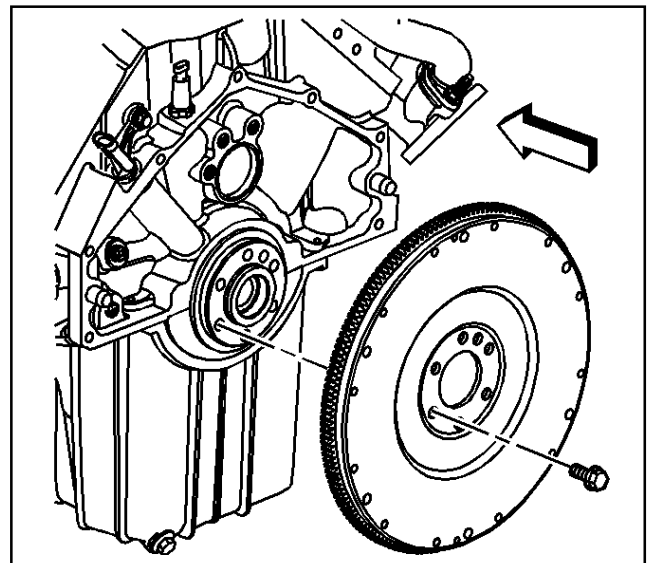

470576

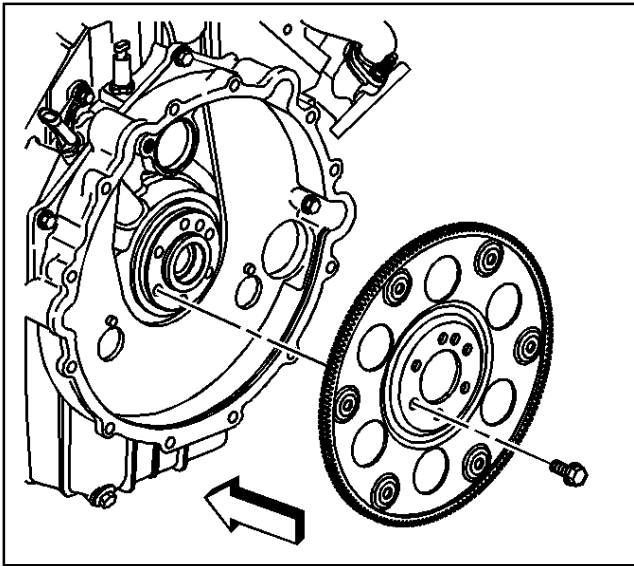

470579

### Engine Flywheel Installation (Medium Duty with AT)

**Important:** Make sure the flywheel is installed correctly. "Engine Side" is stamped on the flywheel to assist with installation.

1. Install the engine flywheel.

**Notice:** Refer to *Fastener Notice* in Cautions and Notices.

2. Install the engine flywheel bolts.

#### Tighten

- 2.1. Tighten the engine flywheel bolts to 80 N·m (59 lb ft) on the first pass.
- 2.2. Tighten the engine flywheel bolts to 100 N·m (74 lb ft) on the final pass.

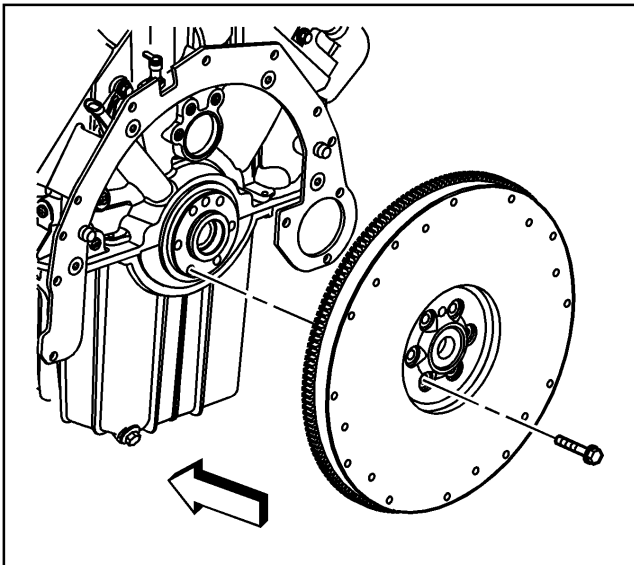

679414

### Engine Flywheel Installation (Medium Duty with MT)

1. Install the engine flywheel.

**Notice:** Refer to *Fastener Notice* in Cautions and Notices.

2. Install the engine flywheel bolts.

#### Tighten

- 2.1. Tighten the engine flywheel bolts to 80 N·m (59 lb ft) on the first pass.
- 2.2. Tighten the engine flywheel bolts to 100 N·m (74 lb ft) on the final pass.

**Crankshaft Balancer Installation**

**Tools Required**

J 42845 Crankshaft Balancer Installer

J 42847 Flywheel Holding Tool

**Notice:** Refer to *Fastener Notice* in Cautions and Notices.

**Important:** Make sure the teeth of the flywheel holding tool engage the engine flywheel teeth.

**Important:** The balancer should be positioned onto the end of the crankshaft as straight as possible prior to tool installation.

1. Install the J 42847 to the starter bolt holes.

**Tighten**

Tighten the J 42847 bolts to 50 N·m (37 lb ft).

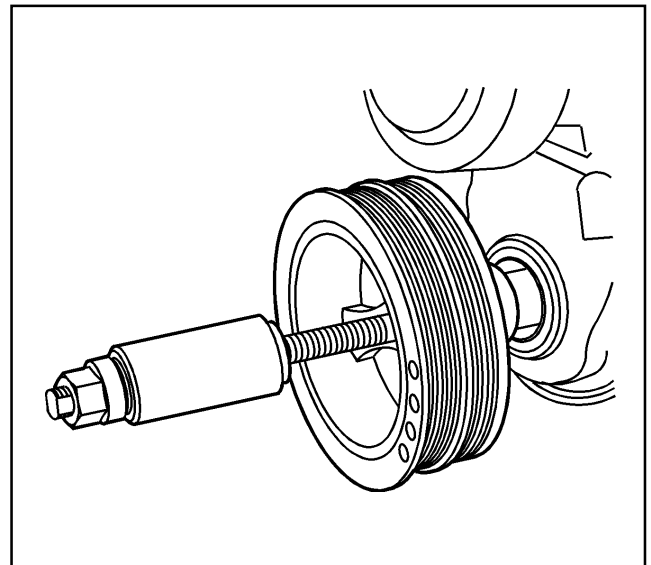

639537

**Important:** Apply grease or clean engine oil to the inside of the crankshaft balancer or the end of the crankshaft, to prevent galling during assembly.

2. Install the balancer onto the end of the crankshaft.

**Important:** Apply the lubricant that comes with J 42845 each time the tool is used. Failure to lubricate J 42845 may prevent the balancer from installing completely.

3. Use the J 42845 in order to install the balancer.

**Important:** The crankshaft balancer must be completely seated against the crankshaft sprocket. Failure to correctly install the crankshaft balancer may allow the crankshaft balancer bolt to come loose, causing engine damage.

4. Tighten the J 42845 until the crankshaft balancer is completely seated against the crankshaft sprocket.

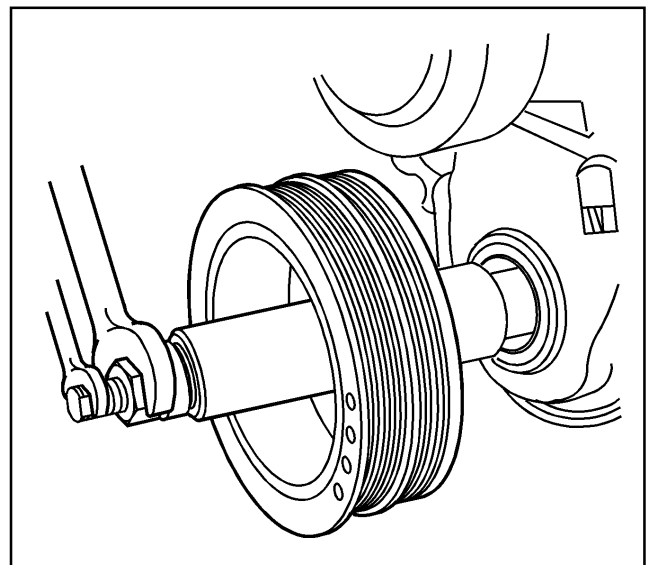

639539

5. Remove the J 42845 from the crankshaft.

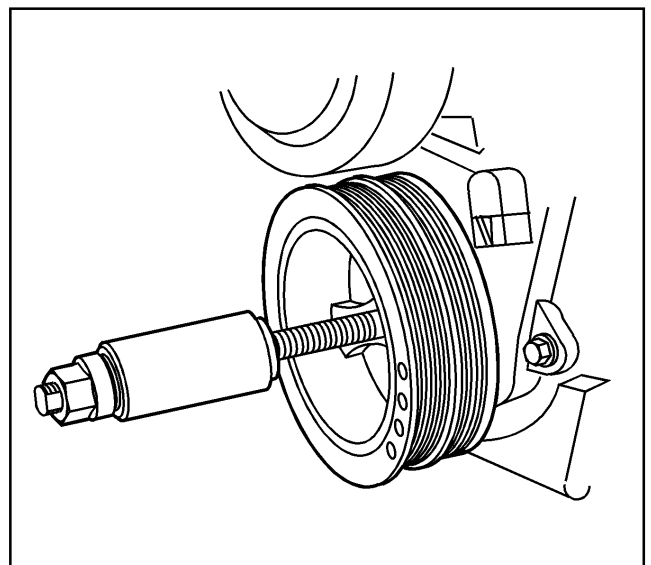

639542

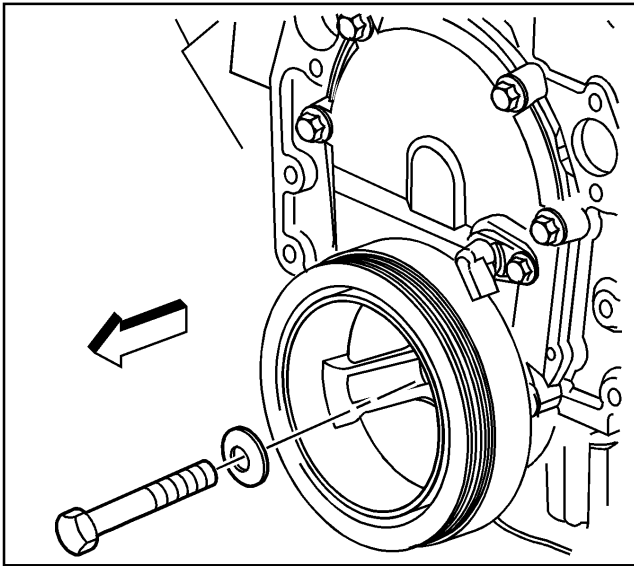

470799

6. Install the crankshaft balancer washer and bolt.

**Tighten**

Tighten the crankshaft balancer bolt to 225 N·m (188 lb ft).

7. Remove the J 42847.

# Description and Operation

## Engine Component Description

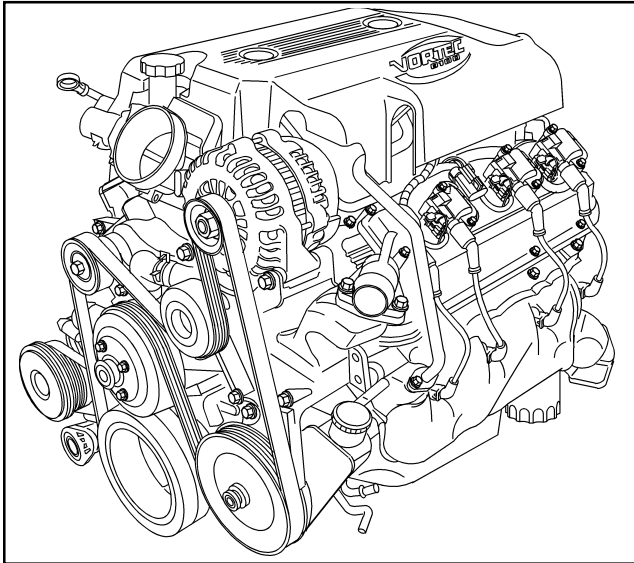

639544

### Cylinder Block

The engine block is made of cast iron and it has eight cylinders arranged in a V shape with four cylinders in each bank. The engine block is a one piece casting with the cylinders encircled by coolant jackets.

### Cylinder Head

The cylinder heads are made of cast iron and have parent metal intake valve guides and intake valve seats. The cast iron exhaust valve guides and powdered metal valve seats are pressed into the exhaust ports. A spark plug is located between the valves in the side of the cylinder head. The water crossover pipe attaches to the front of each cylinder head.

### Camshaft

A steel camshaft is supported by five bearings pressed into the engine block. The camshaft sprocket is mounted to the front of the camshaft and is driven by the crankshaft sprocket through a camshaft timing chain.

Motion from the camshaft is transmitted to the valves by hydraulic roller valve lifters, valve pushrods and ball-pivot type rocker arms. A spiral gear machined into the camshaft near the rear journal drives a shaft assembly which operates the oil pump driveshaft assembly.

### Crankshaft

The crankshaft is made of cast nodular iron. The crankshaft is supported by five crankshaft bearings. The crankshaft bearings are retained by the crankshaft bearing caps. The crankshaft bearing caps are machined with the engine block for proper alignment and clearance. The crankshaft bearing caps are retained by two bolts and

two studs each. The number five crankshaft bearing at the rear of the engine block is the end thrust bearing. The four connecting rod journals (two rods per journal) are spaced 90 degrees apart. The crankshaft position sensor reluctor ring is pushed onto the rear of the crankshaft. The crankshaft position sensor reluctor ring is constructed of powdered metal. The reluctor ring has an interference fit onto the crankshaft and an internal keyway for correct positioning.

### Pistons and Connecting Rods

The pistons are cast aluminum alloy that use two compression rings and one oil control ring assembly. The piston pins are a floating fit in the pistons and the piston pins are retained by a press fit in the connecting rod assembly. The pistons are coated in order to create an interference fit into the cylinder. The connecting rods are forged steel and have precision insert type crankpin bearings. The piston and connecting rod is only serviced as an assembly.

### Valve Train

The valve train is ball pivot type. Motion is transmitted from the camshaft through the hydraulic roller valve lifters and tubular valve pushrods to the valve rocker arms. The valve rocker arm pivots on a ball in order to open the valve. The hydraulic roller valve lifters keep all parts of the valve train in constant contact. Each valve lifter acts as an automatic adjuster and maintains zero lash in the valve train. This eliminates the need for periodic valve adjustment. The valve rocker arm stud and nut retains the valve rocker arm and ball seat. The valve rocker arm stud is threaded into the cylinder head.

### Intake Manifold

The intake manifold is a one-piece design. The intake manifold is made of cast aluminum. The throttle body is attached to the front of the intake manifold. A linear exhaust gas recirculation (EGR) port is cast into the manifold for exhaust gas recirculation mixture. The EGR valve bolts onto the rear of the intake manifold. The fuel rail assembly with eight separate fuel injectors is retained to the intake manifold by four bolts. The fuel injectors are seated in their individual manifold bores with O-ring seals to provide sealing. A Manifold Absolute Pressure (MAP) sensor is mounted on the top of the intake manifold and sealed by an O-ring seal. The MAP sensor is held in place with a retainer bolt. The evaporative emission canister solenoid is located in the front of the intake manifold. The positive crankcase ventilation (PCV) system is internally cast into the intake manifold. There is no PCV valve.

### Exhaust Manifold

The two exhaust manifolds are constructed of cast iron. The exhaust manifolds direct exhaust gases from the combustion chambers to the exhaust system. The right exhaust manifold has a flange for the EGR pipe.

### New Product Information

The purpose of New Product Information is to highlight important technical changes from the previous model year.

Changes may include one or more of the following items:

- Torque values and/or fasteners tightening strategies
- Changed engine specifications
- New sealants and/or adhesives
- Disassembly and assembly procedure revisions
- Engine mechanical diagnostic procedure revisions
- New special tools required
- A component comparison from the previous year

### Torque Values and/or Fastener Tightening Strategies

- All fasteners and threaded holes on the 8.1L engine utilize metric threads.
- Cylinder head, connecting rod and crankshaft bearing cap bolts now apply a torque angle strategy.
- Certain fasteners should not be reused. Bolts, studs or other fasteners that must be replaced will be called out in the specific service procedure.
- The Crankshaft Balancer bolt has a much higher torque specification.

### Changed Engine Specifications

- Crankshaft stroke has changed, bringing displacement to 8.1L (496 cubic inches).
- Piston diameter was changed slightly. Refer to *Engine Mechanical Specifications*.

### New Sealants and/or Adhesives

- An anaerobic gasket maker is used to seal the rear crankshaft bearing cap to the engine block.
- A pipe sealant type material is used on the engine coolant and oil gallery plugs, oil pressure sensor threads and the engine oil cooler fittings.

Refer to *Sealers, Adhesives and Lubricants*

### Disassembly and Assembly Procedure Revisions

The majority of the disassembly and assembly procedures have been revised, due to the newly designed engine assembly.

### Engine Mechanical Diagnostic Procedure Revisions

Base Engine Misfire and Engine Noise Diagnosis information is now provided in tabel form. Potential or probable causes are supplied for each specific concern.

Refer to *A Diagnostic Starting Point - Engine Mechanical*.

### New Special Tools Required

A variety of new tools have been developed to assist in engine disassembly, assembly and on-vehicle service.

Refer to *Special Tools*.

### A Component Comparison from the Previous Year

- The 8.1 liter, L18 engine has replaced the 7.4 liter, L29/LP4/L21 engines.
- Some of the new features include:
  - The L18 has a cast aluminum one piece intake manifold. The 7.4L has a two piece design.
  - The L18 ignition system includes a crankshaft sensor, camshaft sensor and eight individual ignition coils, similar to the LP4/L21.
  - The L18 uses a coolant crossover pipe to route coolant from the left to right cylinder head. The 7.4L allowed coolant to crossover through the intake manifold.
  - The thermostat is located on the coolant crossover pipe.
  - The L18 has a rear-mounted, non-replaceable reluctor ring for the crankshaft position sensor.
  - The L18 crankshaft position sensor is located on the left rear of the engine block.
  - The L18 utilizes an oil deflector for the crankshaft.
  - The L18 does not have engine block expansion plugs on the sides of the engine block.
  - The L18 has an internal Positive Crankcase Ventilation (PCV) system, and does not utilize a PCV valve.
  - The L18 offers an Electronic Throttle Control (ETC) throttle body.
  - The L18 uses a cassette-style seal for the rear of the crankshaft.
  - The L18 uses studs and nuts to retain the valve rocker arms. The 7.4L used bolts to retain the valve rocker arms.
- Refer to *Disassembled Views* and *Engine Component Description*.



Lubrication Description

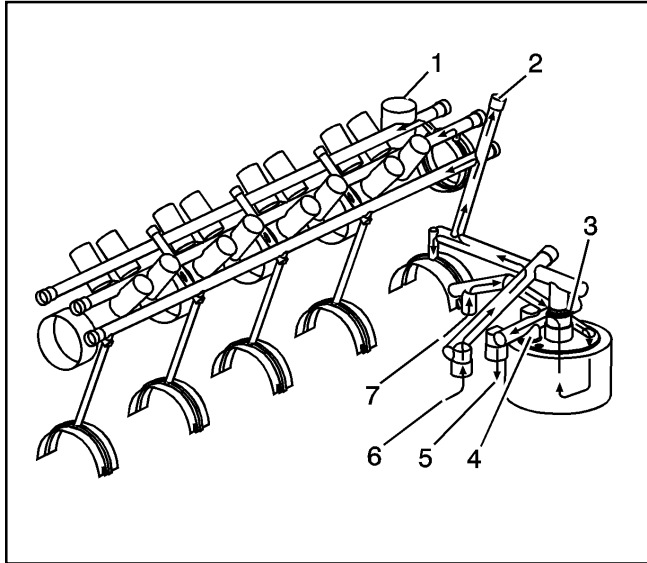

677880

The gear-type oil pump is driven through an extension driveshaft. The extension driveshaft is driven by the oil pump drive, which is gear driven by the camshaft. The oil is drawn from the oil pan through a pickup screen and tube, into the oil pump (7). Pressurized oil flows through the oil filter, into the oil cooler (5), back into the engine (6), up to the oil pressure gauge port (2) and rear crankshaft bearing, and is then distributed to the upper oil galleries. Oil must flow around the oil pump drive (1) in order to reach the right side valve lifters properly. The oil is delivered through internal passages in order to lubricate camshaft and crankshaft bearings and to provide lash control in the hydraulic valve lifters. Oil is metered from the valve lifters through the valve push rods in order to lubricate the valve rocker arms and ball pivots. Oil returning to the oil pan from the cylinder heads and the front camshaft bearing, lubricates the camshaft timing chain and the crankshaft and the camshaft sprockets. There are two bypass valves located in the engine block, above the oil filter. The oil filter bypass valve (4) and the oil cooler bypass valve (3).

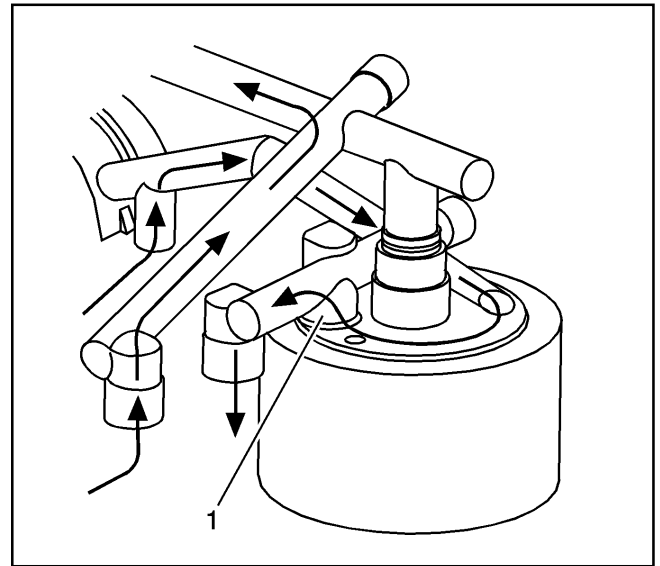

677884

If the oil filter becomes plugged, the pressurized oil is diverted around the top of the oil filter. The oil filter bypass valve (1) is forced open, allowing the oil to continue on to the oil cooler and engine oil passages. No oil filtration occurs because the oil is not allowed into the oil filter.

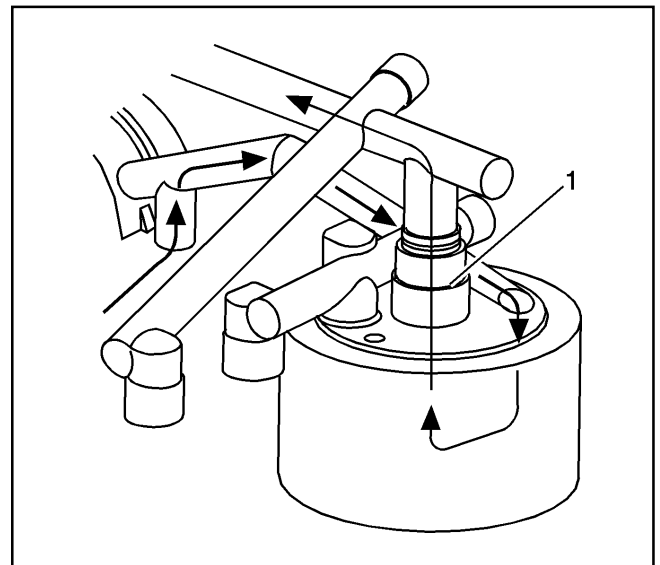

677891

If the oil cooler flow becomes blocked, either from a plugged oil cooler or blocked or kinked oil cooler line, the oil cooler bypass valve (1) is forced open, allowing oil to flow directly into the engine oil passages. Oil does not flow into or out of the engine oil cooler.

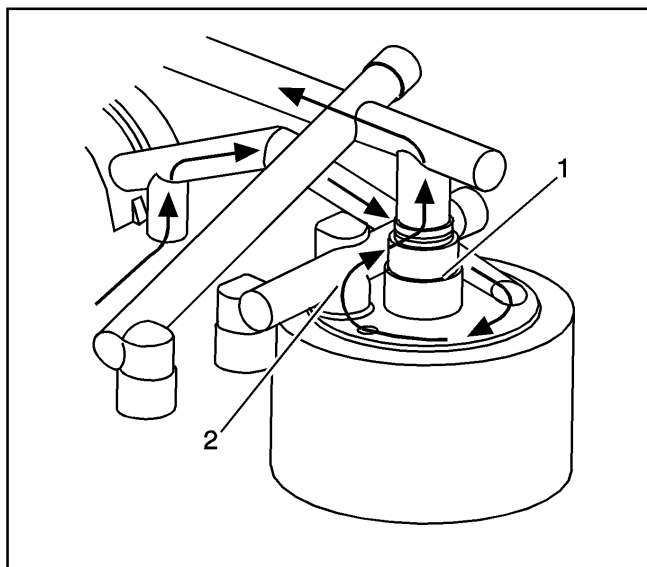

677892

If both the oil filter and the oil cooler are plugged, the pressurized oil is routed around the top of the oil filter, through the oil filter bypass valve (2), through the oil cooler bypass valve (1) and directly into the engine oil passages. Lubrication still occurs, but the oil is not filtered or directed through the oil cooler.

## Separating Parts

**Important:** Many internal engine components will develop specific wear patterns on their friction surfaces.

When disassembling the engine, internal components **MUST** be separated, marked or organized in a way to ensure reinstallation to the original location and position.

Separate, mark or organize the following components:

- Piston to the specific cylinder bore
- Piston rings to the piston
- Connecting rod to crankshaft journal
- Connecting rod to the bearing cap
- Crankshaft and connecting rod bearings
- Camshaft and valve lifters
- Valve lifters, guides, pushrods pivot supports and rocker arms
- Valve to the valve guide
- Valve spring and shim to the cylinder head location
- Engine block crankshaft bearing cap location and direction
- Oil pump drive and driven gears

## Cleanliness and Care

- Throughout this section, it should be understood that proper cleaning and protection of machined surfaces and friction areas is part of the repair procedure. This is considered standard shop practice even if not specifically stated.
- When any internal engine parts are serviced, care and cleanliness is important.
- When components are removed for service, they should be marked, organized or retained in a specific order for reassembly.
- At the time of installation, components should be installed in the same location and with the same mating surface as when removed.
- An automobile engine is a combination of many machined, honed, polished and lapped surfaces with tolerances that are measured in millimeters or thousandths of an inch. These surfaces should be covered or protected to avoid component damage.
- A liberal coating of clean engine oil should be applied to friction areas during assembly.
- Proper lubrication will protect and lubricate friction surfaces during initial operation.

## Replacing Engine Gaskets

### Gasket Reuse and Applying Sealant

- Do not reuse any gasket unless specified.
- Gaskets that can be reused will be identified in the service procedure.
- Do not apply sealant to any gasket or sealing surface unless specified in the service procedure.

### Separating Components

- Use a rubber mallet in order to separate the components.
- Bump the part sideways in order to loosen the components.
- Bumping of the component should be done at bends or reinforced areas of the component to prevent distortion or the components.

### Cleaning Gasket Surfaces

- Use care to avoid gouging or scraping the sealing surfaces.
- Use a plastic or wood scraper in order to remove all the sealant from the components.

Do not use any other method or technique to remove the sealant or the gasket material from a part.

- Do not use abrasive pads, sand paper or power tools to clean the gasket surfaces.
  - These methods of cleaning can cause damage to the component sealing surfaces.
  - Abrasive pads also produce a fine grit that the oil filter cannot remove from the engine oil.

This fine grit is abrasive and can cause internal engine damage.

### Assembling Components

- Assemble components using only the sealant (or equivalent) that is specified in the service procedure.
- Sealing surfaces must be clean and free of debris or oil.
- Specific components such as crankshaft oil seals or valve stem oil seals may require lubrication during assembly.
- Components requiring lubrication will be identified in the service procedure.
- Apply only the amount of sealant specified in the service procedure to a component.
- Do not allow the sealant to enter into any blind threaded holes, as the sealant may prevent the fastener from clamping properly or cause component damage when tightened.
- Tighten fasteners to the proper specifications. DO NOT overtighten the fasteners.

### Use of RTV and Anaerobic Sealer

#### Sealant Types

**Important:** The correct sealant and amount of sealant must be used in the proper location to prevent oil leaks, coolant leaks or the loosening of the fasteners. DO NOT interchange the sealants. Use only the sealant (or equivalent) as specified in the service procedure.

The following 2 major types of sealant are commonly used in engines:

- Aerobic sealant (Room Temperature Vulcanizing (RTV))
- Anaerobic sealant, which include the following:
  - Gasket eliminator
  - Pipe
  - Threadlock

#### Aerobic Type Room Temperature Vulcanizing (RTV) Sealant

Aerobic type Room Temperature Vulcanizing (RTV) sealant cures when exposed to air. This type of sealant is used where 2 components (such as the intake manifold and the engine block) are assembled together.

Use the following information when using RTV sealant:

- Do not use RTV sealant in areas where extreme temperatures are expected. These areas include:
  - The exhaust manifold
  - The head gasket
  - Any other surfaces where a different type of sealant is specified in the service procedure.
- Always follow all the safety recommendations and the directions that are on the RTV sealant container.
- Use a plastic or wood scraper in order to remove all the RTV sealant from the components.

**Important:** Do not allow the RTV sealant to enter any blind threaded holes, as it may prevent the fasteners from clamping properly or cause damage when the fastener is tightened.

- The surfaces to be sealed must be clean and dry.
- Use a RTV sealant bead size as specified in the service procedure.
- Apply the RTV sealant bead to the inside of any bolt holes areas.
- Assemble the components while the RTV sealant is still wet to the touch (within 3 minutes). Do not wait for the RTV sealant to skin over.
- Tighten the fasteners in sequence (if specified) and the proper torque specifications. DO NOT overtighten the fasteners.

#### Anaerobic Type Gasket Eliminator Sealant

Anaerobic type gasket eliminator sealant cures in the absence of air. This type of sealant is used where 2 rigid parts (such as castings) are assembled together. When 2 rigid parts are disassembled and no sealant or gasket is readily noticeable, then the 2 parts were probably assembled using an anaerobic type gasket eliminator sealant.

Use the following information when using gasket eliminator sealant:

- Always follow all the safety recommendations and directions that are on the gasket eliminator sealant container.
- Apply a continuous bead of gasket eliminator sealant to one flange.

The surfaces to be sealed must be clean and dry.

**Important:** Do not allow the gasket eliminator sealant to enter any blind threaded holes, as the gasket eliminator sealant may prevent the fasteners from clamping properly, seating properly or cause damage when the fastener is tightened.

- Apply the gasket eliminator sealant evenly to get a uniform thickness of the gasket eliminator sealant on the sealing surface.

**Important:** Gasket eliminator sealed joint fasteners that are partially torqued and the gasket eliminator sealant allowed to cure more than five minutes, may result in incorrect shimming and sealing of the joint.

- Tighten the fasteners in sequence (if specified) and to the proper torque specifications. DO NOT overtighten the fasteners.
- After properly tightening the fasteners, remove the excess gasket eliminator sealant from the outside of the joint.

### Anaerobic Type Threadlock Sealant

Anaerobic type threadlock sealant cures in the absence of air. This type of sealant is used for threadlocking and sealing of bolts, fittings, nuts and studs. This type of sealant cures only when confined between 2 close fitting metal surfaces.

- Always follow all safety recommendations and directions that are on the threadlock sealant container.
- The threaded surfaces to be sealed must be clean and dry.
- Apply the threadlock sealant as specified on the threadlock sealant container.

**Important:** Fasteners that are partially torqued and then the threadlock sealant allowed to cure more than five minutes, may result in incorrect clamp load of assembled components.

- Tighten fasteners in sequence (if specified) and to the proper torque specifications. DO NOT overtighten the fasteners.

### Anaerobic Type Pipe Sealant

Anaerobic type pipe sealant cures in the absence of air and remains pliable when cured. This type of sealant is used where 2 parts are assembled together and require a leak proof joint.

Use the following information when using pipe sealant:

- Do not use pipe sealant in areas where extreme temperatures are expected. These areas include:
  - The exhaust manifold
  - The head gasket
  - Surfaces where a different sealant is specified
- Always follow all the safety recommendations and the directions that are on the pipe sealant container.
- The surfaces to be sealed must be clean and dry.
- Use a pipe sealant bead of the size or quantity as specified in the service procedure.

**Important:** Do not allow the pipe sealant to enter any blind threaded holes, as the pipe sealant may prevent the fasteners from clamping properly, seating properly or cause damage when the fastener is tightened.

- Apply the pipe sealant bead to the inside of any bolt hole areas.
- Apply a continuous bead of pipe sealant to 1 sealing surface.
- Tighten the fasteners in sequence (if specified) and to the proper torque specifications. DO NOT overtighten the fasteners

### Tools and Equipment

- Special tools are listed and illustrated throughout this section with a complete listing at the end of the section. These tools (or their equivalents) are specially designed to quickly and safely accomplish the operations for which they are intended. The use of these special tools will also minimize possible damage to engine components. Some precision measuring tools are required for inspection of certain critical components. Torque wrenches and a torque angle meter are necessary for the proper tightening of various fasteners.
- To properly service the engine assembly, the following items should be readily available:
  - Approved eye protection and safety gloves
  - A clean, well-lit work area
  - A suitable parts cleaning tank
  - A compressed air supply
  - Trays or storage containers to keep parts and fasteners organized
  - An adequate set of hand tools
  - Approved engine repair stand
  - An approved engine lifting device that will adequately support the weight of the components

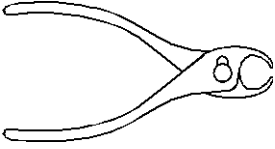
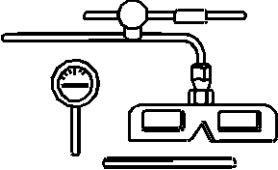
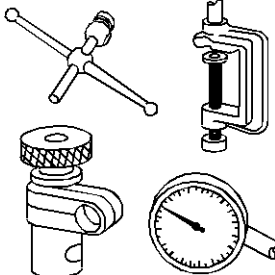
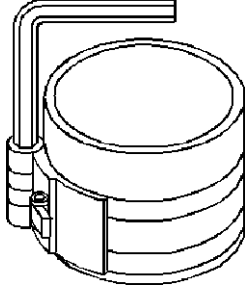
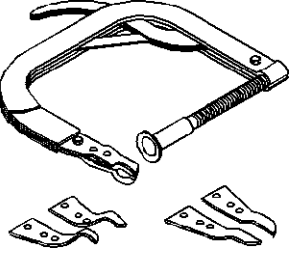
Illustration	Tool Number/Description
	<p>J 3049-A Hydraulic Lifter Remover</p>
	<p>J 7872 Magnetic Base Dial Indicator</p>
	<p>J 8001 Dial Indicator Set</p>
	<p>J 8037 Piston Ring Compressor</p>
	<p>J 8062 Valve Spring Compressor (Cylinder Head Off)</p>

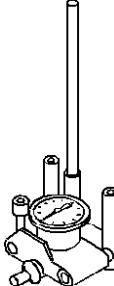
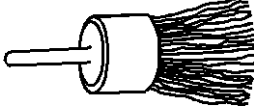
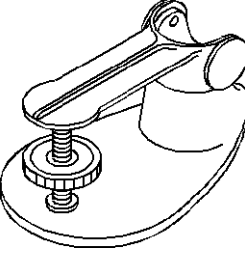
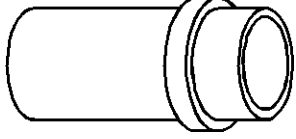
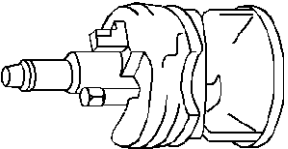
Illustration	Tool Number/Description
	<p>J 8087 Cylinder Bore Checking Gauge</p>
	<p>J 8358 Carbon Removal Brush</p>
	<p>J 9666 Valve Spring Tester</p>
	<p>J 22102 Crankshaft Sprocket Installer</p>
	<p>J 24270 Cylinder Bore Ridge Reamer</p>

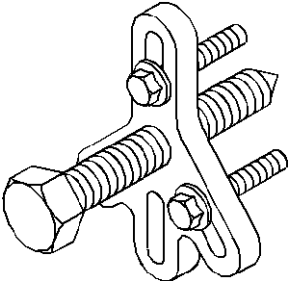
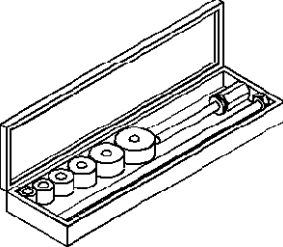
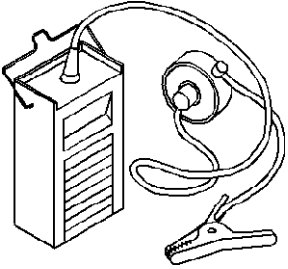
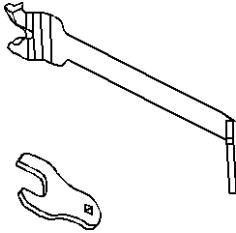
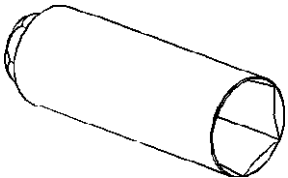
Illustration	Tool Number/Description
	<p>J 24420-C Harmonic Balancer Puller</p>
	<p>J 33049 Camshaft Bearing Service Set</p>
	<p>J 36660 Electronic Torque Angle Meter</p>
	<p>J 41240 Fan Clutch Wrench</p>
	<p>J 41712 Oil Pressure Sending Unit Socket</p>

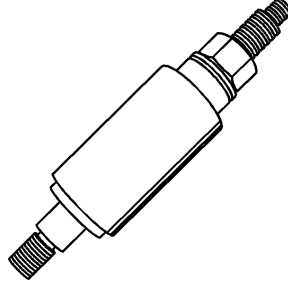
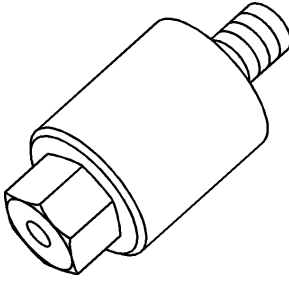
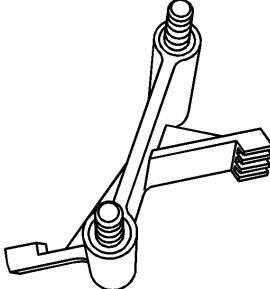
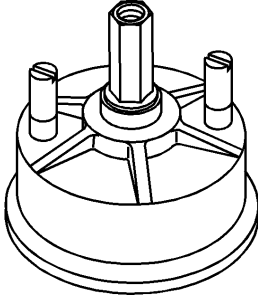
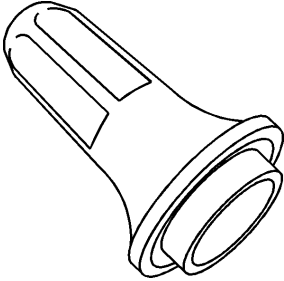
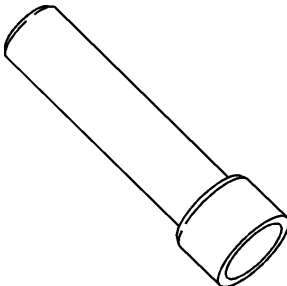
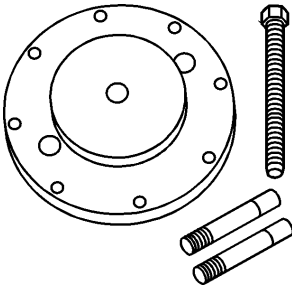
Illustration	Tool Number/Description
	<p>J 42845 Crankshaft Balancer Installer</p>
	<p>J 42846 Crankshaft Protector Button</p>
	<p>J 42847 Flywheel Holding Tool</p>
	<p>J 42849 Crankshaft Rear Seal Installer</p>
	<p>J 42851 Front Cover Oil Seal Installer</p>

Illustration	Tool Number/Description
	<p>J 43105 Valve Stem Seal Installer</p>
	<p>J 43320 Crankshaft Rear Seal Puller</p>