

1100 Series

1103A-33G

Diesel Engine - ElectropaK

30.4 kWm 1500 rev/min
35.4 kWm 1800 rev/min



Compact, Efficient Power

- 1100 Series is the result of an intensive period of customer research that has guided the development of the range.
- The new 3.3 litre cylinder block ensures bore roundness is maintained under the pressures of operation. It also ensures combustion and mechanical noise is lowered.
- A new cylinder head has re-established Perkins mastery of air control.

Quality by Design

- Product design and Class A manufacturing improvements enhance product reliability while maintaining Perkins legendary reputation for durability.

Cost Effective Power

- Compact size and low noise.
- Lower fuel consumption and oil use.
- 500 hour service intervals.
- Two year warranty.

Product Support

- Perkins actively pursues product support excellence by ensuring our distribution network invest in their territory - strengthening relationships and providing more value to you, our customer
- Through an experienced global network of distributors and dealers, fully trained engine experts deliver total service support around the clock, 365 days a year. They have a comprehensive suite of web based tools at their fingertips covering technical information, parts identification and ordering systems, all dedicated to maximising the productivity of your engine
- Throughout the entire life of a Perkins engine, we provide access to genuine OE specification parts and service. We give 100% reassurance that you receive the very best in terms of quality for lowest possible cost .. wherever your Perkins powered machine is operating in the world

Building upon Perkins proven reputation within the power generation industry, the 1100 Series range of ElectropaK engines now fit even closer to customers needs.

In the world of power generation success is only gained by providing more for less. With the 1103A-33G Perkins has engineered even higher levels of reliability, yet lowered the cost of ownership.

1100A units are designed for territories that do not require compliance to EPA or EU emissions legislation. These units are able to meet TA luft legislation.

Engine speed rev/min	Operation Type	Typical Generator Output (Net)		Engine Power			
				Gross		Net	
		kVA	kWe	kW	bhp	kW	bhp
1500	Prime Power	30.0	24.0	28.2	37.8	27.7	37.1
	Standby (maximum)	33.0	26.4	31.0	41.6	30.4	40.8
1800	Prime Power	34.9	27.9	33.2	44.5	32.2	43.2
	Standby (maximum)	38.2	30.6	36.5	48.9	35.4	47.5

The above ratings represent the engine performance capabilities to conditions specified in ISO 8528/1, ISO 3046/1:1986, BS5514/1 Derating may be required for conditions outside these; consult Perkins Engines Company Limited

Generator powers are typical and are based on an average alternator efficiency and a power factor (cos. ϕ) of 0.8
Fuel specification: BS 2869: Part 2 1998 Class A2 or DIN EN 590
Lubricating oil: 15W40 to API CG4

Rating Definitions

Prime power: Variable load. Unlimited hours usage with an average load factor of 80% of the published prime power over each 24 hour period. A 10% overload is available for 1 hour in every 12 hours of operation.
Standby power: Variable load. Limited to 500 hours annual usage, up to 300 hours of which may be continuous running. No overload is permitted.

1100 Series

1103A-33G

Standard ElectropaK Specification

Air inlet

- Mounted air filter

Fuel system

- Rotary type pump
- Ecoplus fuel filter

Lubrication system

- Wet sump with filler and dipstick
- Spin-on oil filter

Cooling system

- Thermostatically-controlled system with gear-driven circulation pump and belt-driven pusher fan
- Mounted radiator and piping

Electrical equipment

- 12 volt starter motor and 12 volt 65 amp alternator with DC output
- 12 volt shutdown solenoid energised to run

Flywheel and housing

- High inertia flywheel to SAE J620 size 10/11^{1/2}
- SAE 3 flywheel housing

Mountings

- Front engine mounting bracket

Literature

- User's Handbook

Optional equipment

- Woodward electronic governor (LCG2)
- Workshop manual
- Parts book

Option Groups

A selection of optional items is available to enable the customer to prepare a specification precisely matched to the needs.

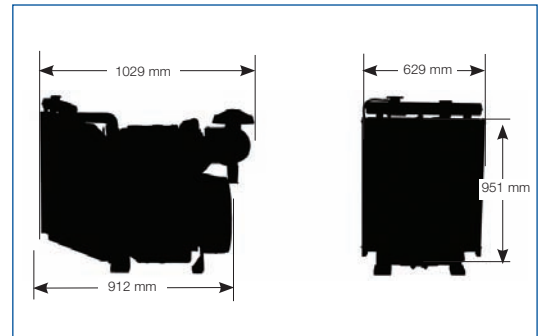

Engine speed	Fuel Consumption litres/hour Temperature/Tropical			
	1500 rev/min		1800 rev/min	
	UK g/hr	l/hr	UK g/hr	l/hr
At standby power	1.73	7.9	2.08	9.5
At prime power	1.56	7.1	1.89	8.6
At 75% of prime power	1.18	5.4	1.45	6.6
At 50% of prime power	0.85	3.9	1.07	4.9

General Data

Number of cylinders	3 vertical in-line
Bore and stroke	105 x 127 mm
Displacement	3.3 litres
Aspiration	Naturally aspirated
Cycle	4 stroke
Combustion system	Direct injection
Compression ratio	19.25:1
Rotation	Anti-clockwise viewed from flywheel
Cooling system	Water-cooled
Total lubrication system capacity	7.9 litres
Total coolant capacity	10.2 litres
Dimensions	Length 1029 mm Width 629 mm Height 951 mm
Dry Weight (approximately)	412 kg

Final weight and dimensions will depend on completed specification.



Perkins Engines Company Limited

Peterborough PE1 5NA
United Kingdom
Telephone +44 (0)1733 583000
Fax +44 (0)1733 582240
www.perkins.com

All information in this document is substantially correct at time of printing and may be altered subsequently
Publication No.1780/06/11 Produced in England ©2006 Perkins Engines Company Limited

Distributed by